

CREMUL D.96A

Multiple credit advice message

Recommendation of D6 EWG sub-working group Finance

for the use of the UN/EDIFACT-Message

Version 1.3 from May 3rd, 2001

Table of contents

Table of contents	1
1. Introduction	2
1.1. Scope	2
1.1.1. Functional Definition	2
1.1.2. Field of Application	2
1.1.3. Principles.....	2
1.2. References	2
1.3. Data Segment Clarification	3
1.4. Rules for segments FII and NAD	4
1.4.1. Dependencies of FII and NAD relevant for transactions in PAYMUL and DIRDEB D.96A	4
1.4.2. Directory D.96A: Major parties involved in transaction	5
1.4.3. Logical differences between MIGs of D.96A and of D.91.2	5
1.5. Codes to be used in DE 1131 and DE 3055 (associated with DE 3434 – Institution Branch Number)	7
2. Message Layout	10
2.1. Branching Diagram	10
2.2. Message Structure	15
3. Segment Layout	20
3.1. Introduction	20
3.1.1. UN/EDIFACT Directory 96.A Block.....	20
3.1.2. D6 Description Block.....	20
3.1.3. CRG Description Block.....	21
3.2. Segment Description	21
4. History of changes	127

1. Introduction

This specification provides the definition of the Multiple credit advice message (CREMUL) to be used in Electronic Data Interchange (EDI) between trading partners involved in administration, commerce and transport.

1.1. Scope

1.1.1. Functional Definition

A Multiple Credit Advice message is sent by an Account Servicing Financial Institution to the Account Owner or to a third party, which has agreed bilaterally in advance, that its account (s) has been or will be credited for specified amount (s) on the date (s) indicated, in settlement of the referenced business transaction (s).

1.1.2. Field of Application

The Multiple credit advice message may be used for both national and international trade. It is based on universal commercial practice and is not dependent on the type of business or industry.

1.1.3. Principles

- A CREMUL may cover the financial settlement of one or more commercial trade transactions, such as invoices, credit notes, debit notes, etc. It is not intended for use in securities trading.
- Several credit accounts, value dates, entry dates and currencies may be specified.

1.2. References

This document is based on:

Title	Version	Remarks	Source
ISO 9735 Electronic data interchange for administration, commerce and transport (EDIFACT) – Application level syntax rules	Syntax version number: 3		http://www.iso.ch/cate/cat.html

ISO 646 Information processing – ISO 7-bit coded character set for information interchange			http://www.iso.ch/cate/cat.html
UNITED NATIONS TRADE DATA INTERCHANGE DIRECTORY (UNTDID)	D.96A	Definition CREMUL	http://www.unece.org/trade/untdid
UNITED NATIONS TRADE DATA INTERCHANGE DIRECTORY (UNTDID)	D.00B	UNCL (codelist) only	http://www.unece.org/trade/untdid
Recommended Practice For Message Flow And Security For EDIFACT Payments (D6)	Version 2.3	D6_RecPract_2v03.pdf	http://www.edifact-wg.org
CREMUL D.96A Multiple credit advice message, Recommendation of D6 Sub Working Group Finance for the use of the UN/EDIFACT Message	Version 1.0	CREMUL_19991103.rtf	
D6 Referencing Rules and Recommendations	Version 1.1	D6_RefRules_1v01.pdf	http://www.edifact-wg.org

1.3. Data Segment Clarification

The following semantic principles apply to the message and are intended to facilitate the understanding and implementation of the message:

The Multiple Credit Advice message is structured in three levels: A, B and C.

- Level A (Segments UNH, BGM, DTM and *BUS (not used)*, Segment Groups 1, 2, 3 and 28 and Segments CNT and UNT) contains general data related to the whole message.
- Level B (Segment Groups 4 to 9) is based on the following rules: Level B contains data which applies to all the dependent C levels, such as,
 - Same area Code: When the BUS segment is used, domestic and international items should not be mixed in the same sequence of B and C levels.
 - Same currency and same account: The items to be grouped must refer to the same account. The currency to be booked must be the same as that of the account.
 - Same value date: The items must have the same value date.
 - Same entry date: The items must be booked on the same day.
 - Same bank operation code: The items must bear the same bank operation code.

Remark: If, for the same receiver, one of these 5 basic pieces of information changes, a new level B is required.

- Level C (Segment Groups 10 to 27) contains the individual transactions, which are related to the data stored on level B.

The structure of the message is designed to allow several B and C levels, each level B being followed by one or several C levels.

Where a choice of code or text is given only the code element should be used wherever possible.

1.4. Rules for segments FII and NAD

1.4.1. Dependencies of FII and NAD relevant for transactions in PAYMUL and DIRDEB D.96A

	PAYMUL level B Party Qualifier (DE 3035)	PAYMUL level C Party Qualifier (DE 3035)	DIRDEB level B Party Qualifier (DE 3035)	DIRDEB level C Party Qualifier (DE 3035)
Only FII, no NAD. C078 must contain the account holder name.	FII+OR	FII+BF	FII+BF	FII+PH
No FII, only 1 NAD. Full address is required.	<i>Not allowed</i>	NAD+BE	<i>Not allowed</i>	<i>Not allowed</i>
FII and 1 NAD; both defining the same party (account owner). FII-C078 must not contain the account holder name.	FII+OR NAD+PL	FII+BF NAD+PE	FII+BF NAD+PE	FII+PH NAD+PL
FII and 1 NAD; NAD defining a party different to the account owner in FII. FII-C078 must contain the account holder name.	FII+OR NAD+OY	FII+BF NAD+BE	FII+BF NAD+BE	FII+PH NAD+HX
FII and 2 NAD; one NAD defining the account owner (FII-C078 must not contain the account holder name) and one NAD defining a party different to the account owner in FII (full address is required).	FII+OR NAD+PL NAD+OY	FII+BF NAD+PE NAD+BE	FII+BF NAD+PE NAD+BE	FII+PH NAD+PL NAD+HX

1.4.2. Directory D.96A: Major parties involved in transaction

Message D.96A	Level B			Level C		
	Ordering customer (other than the account owner)		Account owner on the ordering side	(FII+I1)	Account owner on the receiving side	Receiving party (other than the account owner)
PAYMUL	NAD+OY	→	FII+OR NAD+PL	→	FII+BF NAD+PE	→ NAD+BE
PAYMUL	NAD+OY	→	FII+OR NAD+PL	→	FII+BQ	→ NAD+RV NAD+BE
DIRDEB	NAD+BE	→	FII+BF NAD+PE	→	FII+PH NAD+PL	→ NAD+HX

1.4.3. Logical differences between MIGs of D.96A and of D.91.2

Directory D.96A	Directory 91.2	Comment to the differences in PAYMUL D.96A and PAYORD 91.2
<i>Level B</i>		
FII+OR	FII+OR	No differences
FII+OR NAD+PL	FII+OR NAD+OY	If ordering customer and account owner (FII+OR) on the ordering side are the same, additional address details have to be added in different NAD segments: <ul style="list-style-type: none"> In D.96A NAD+PL defines always the account owner In 91.2 NAD+OY defines the account owner only if no NAD+PL exists
FII+OR NAD+OY	FII+OR NAD+PL	If ordering customer and account owner (FII+OR) on the ordering side are not the same, additional address details have to be added in different NAD segments: <ul style="list-style-type: none"> In D.96A NAD+OY defines always an ordering party different to the account owner

	NAD+OY	<ul style="list-style-type: none"> In 91.2 NAD+OY defining an ordering party different to the account owner is only allowed together with an NAD+PL defining the account owner
FII+OR NAD+PL NAD+OY	FII+OR NAD+PL NAD+OY	<p>No differences:</p> <p>NAD+PL defines the same party as FII+OR (=account owner), and</p> <p>NAD+OY defines an ordering customer other than the account owner.</p>
<i>Level C</i>		
FII+BF	FII+BF	No differences
FII+BF NAD+PE	FII+BF NAD+BE	<p>If final beneficiary and account owner (FII+BF) on the receiving side are the same, additional address details have to be added in different NAD segments:</p> <ul style="list-style-type: none"> In D.96A NAD+PE defines always the account owner In 91.2 NAD+BE defines the account owner only if no NAD+PE exists
FII+BF NAD+BE	FII+BF NAD+PE NAD+BE	<p>If final beneficiary and account owner (FII+BF) on the receiving side are not the same, additional address details have to be added in different NAD segments:</p> <ul style="list-style-type: none"> In D.96A NAD+BE defines always a final beneficiary different to the account owner In 91.2 NAD+BE defining a final beneficiary different to the account owner is only allowed together with an NAD+PE defining the account owner
FII+BF NAD+PE NAD+BE	FII+BF NAD+PE NAD+BE	<p>No differences:</p> <p>NAD+PE defines the same party as FII+BF (=account owner), and</p> <p>NAD+BE defines a final beneficiary other than the account owner.</p>

1.5. Codes to be used in DE 1131 and DE 3055 (associated with DE 3434 – Institution Branch Number)

DE3434 – DE1131 (Code List Qualifier)	25 = Bank identification
	43 = CHIPS Participant ID
	44 = CHIPS Universal ID
	154 = Bank branch sorting identification
	155 = Automated clearing house
	157 = Clearing code
DE3434 – DE3055 (Code List Responsible Agency, coded)	5 = ISO (International Organization for Standardization)
	19 = FRRC (Federal Reserve Routing Code)
	108 = FR, Banque de France
	114 = US, ABA (American Bankers Association)
	118 = SE, Svenska Bankfoerenigen
	119 = IT, Associazione Bancaria Italiana
	121 = CH, Telekurs AG
	122 = CH, Swiss Securities Clearing Corporation
	124 = NO, Norwegian Bankers Ass.
	125 = FI, The Finnish Bankers' Association
	128 = BE, Belgian Bankers' Association
	130 = DK, PBS (Pengainstitutternes Betalings Service)
	131 = DE, German Bankers Association

133 = GB, Association for Payment Clearing Services
137 = AT, Verband oesterreichischer Banken und Bankiers
171 = NL, Interpay Girale Services
202 = PT, Banco de Portugal
275 = ES, Banco de España
ZA7 = TW, Taiwanese Bankers' Association (D6 code)
Zxx = If no code exists, then "Z" + "ISO 3166 two alpha country code"

These codes should be combined as indicated in the following table:

To identify a financial institution by the following code	1131 Code	3055 Code
ISO Bank Identifier Code	25	5
Fedwire Id	25	19
French Bank Code	25	108
Swedish Bank Clearing Number	157	118
Italian Bank Code	25	119
Swiss Bank Clearing Number	157	121
Norwegian Bank Code	25	124
Finnish Bank Code	25	125
Belgian Bank Code	25	128
Danish Bank Code	25	130

German Bankleitzahl	25	131
GB Bank Sort Code	154	133
Austrian Bankleitzahl	25	137
Dutch Bank Code	25	171
Portuguese Bank Code	25	202
Portuguese Clearing House Code	155	202
Spanish Bank code	25	275
Chinese Taipei Bank Code	154	ZA7 (D6 code)
CHIPS Participant ID	43	114
CHIPS Universal ID	44	114

2. Message Layout

2.1. Branching Diagram

The use of the shadowed segments is either not recommended or depends upon national requirements. These segments are marked with **N** in the chapter “Segment Layout” without further description.

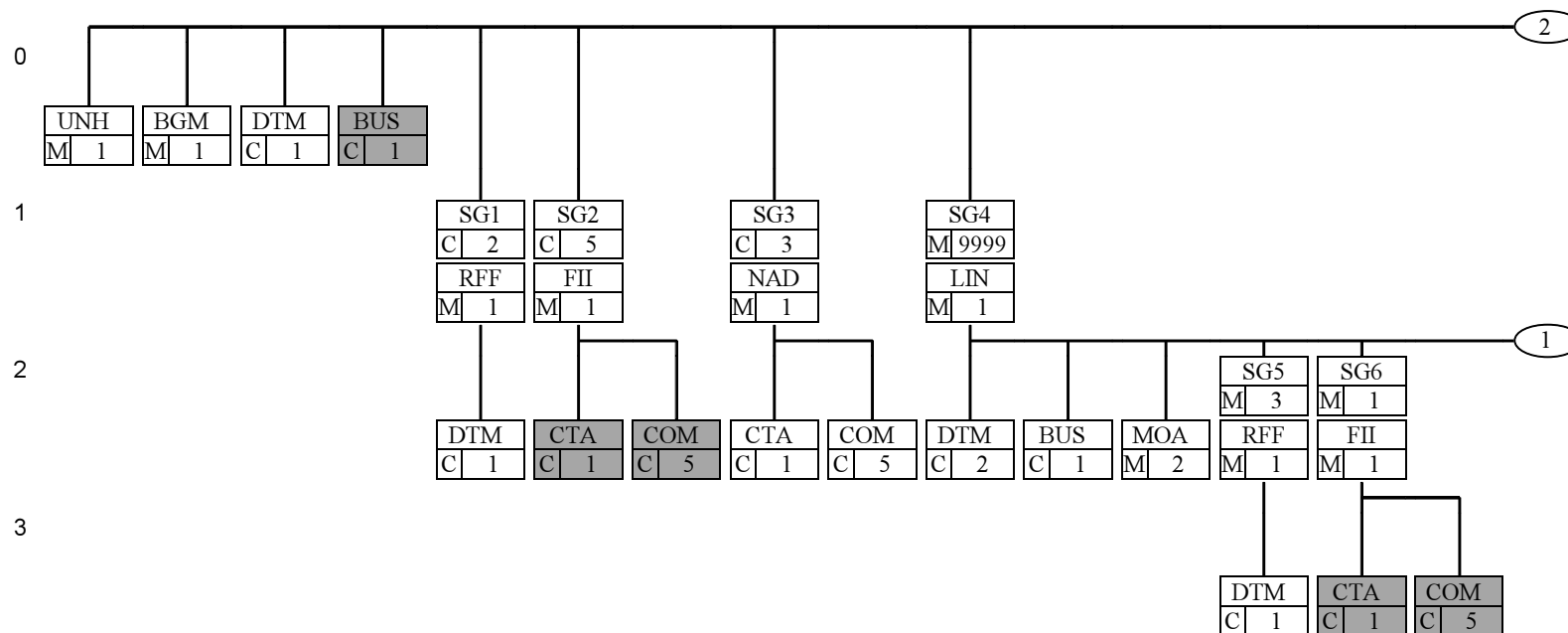

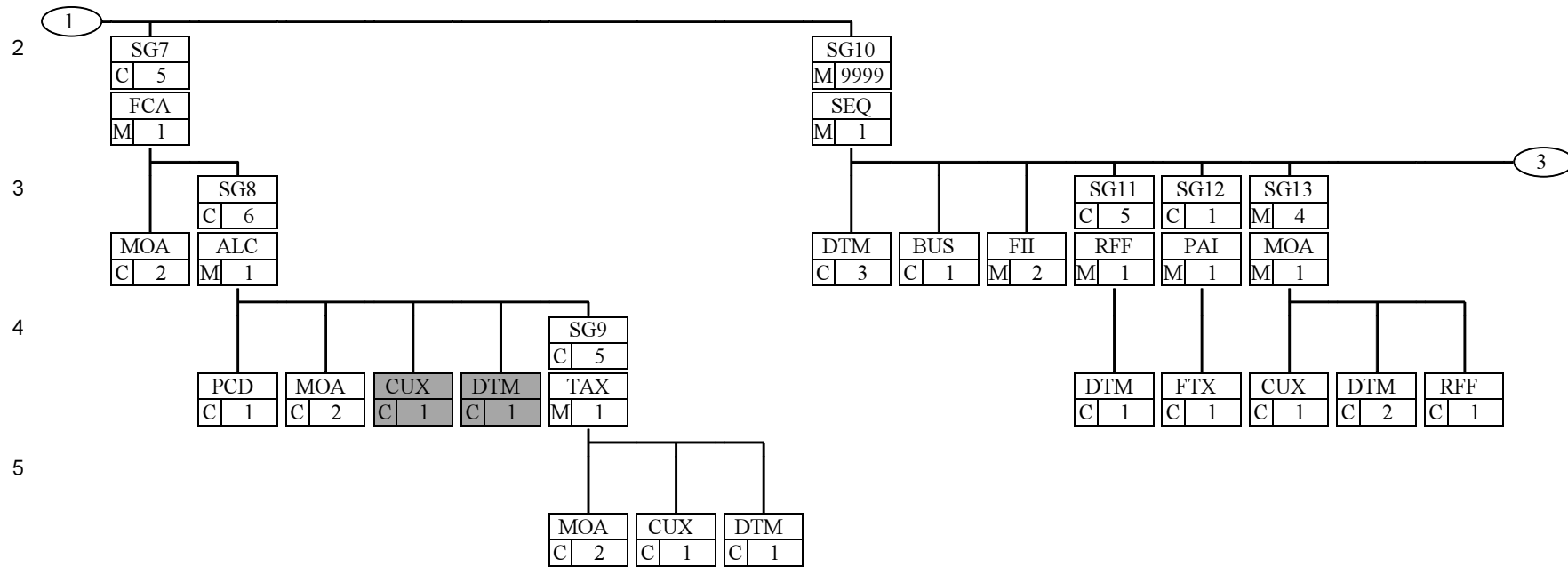

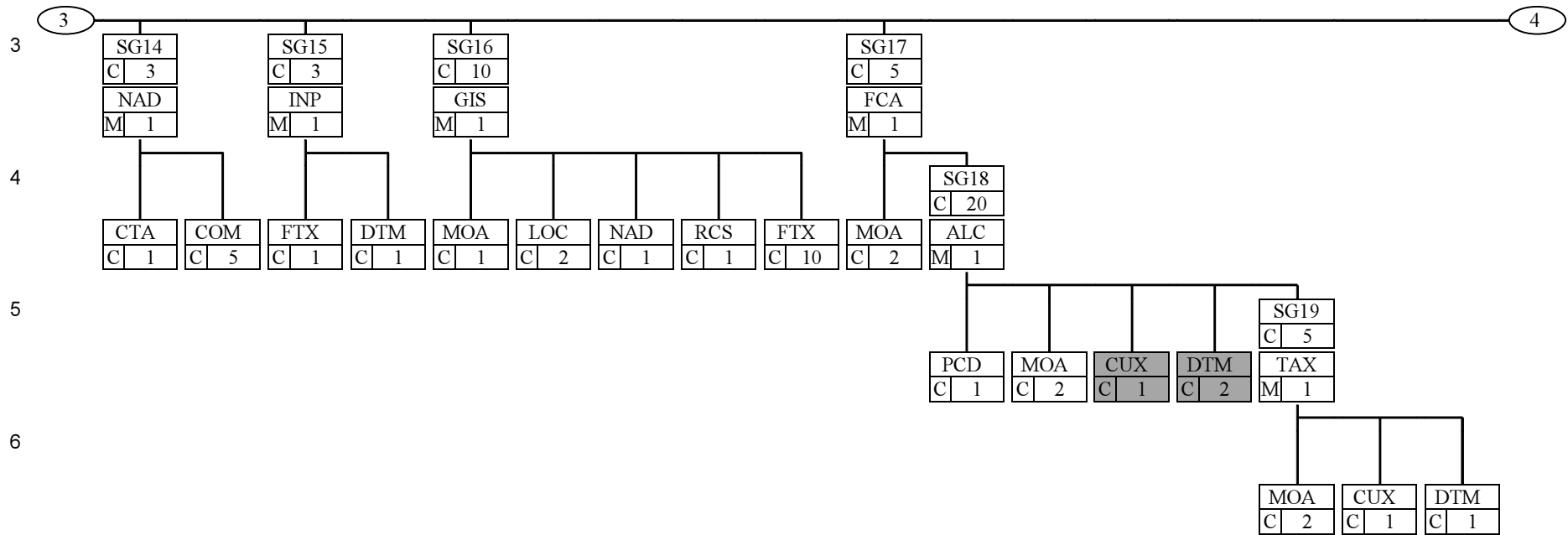

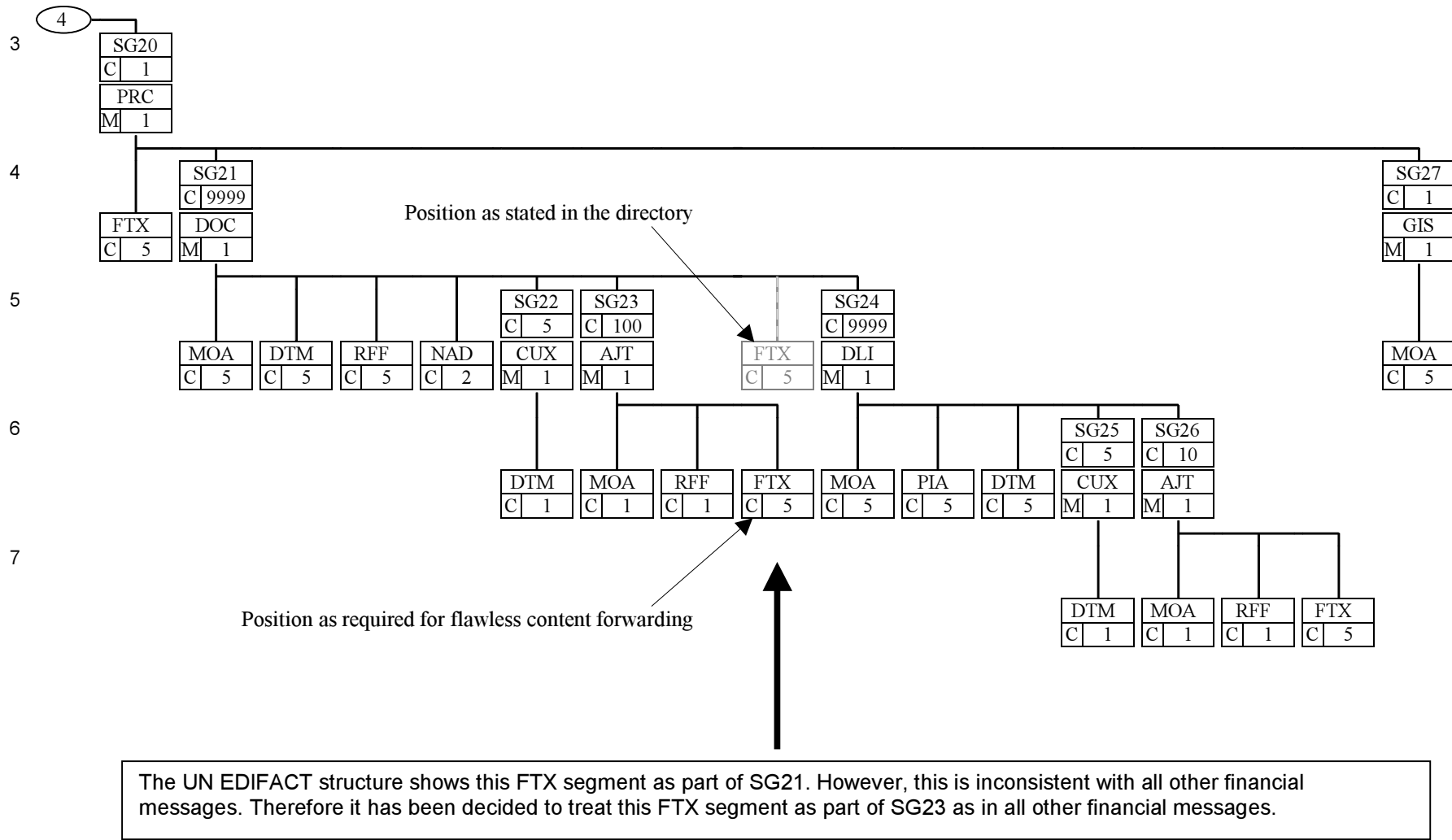

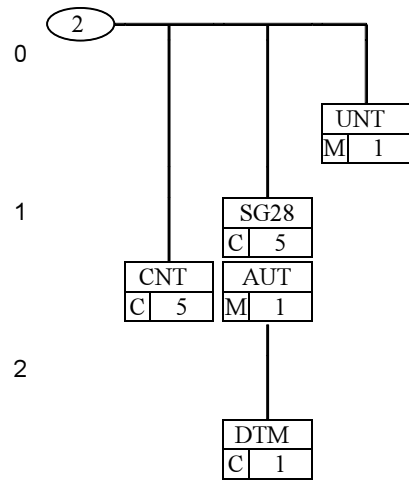

2.2. Message Structure

Pos	Tag Name	S	R
0010	UNH Message header	M	1
0020	BGM Beginning of message	M	1
0030	DTM Date/time/period	C	1
0040	BUS Business function	C	1
0050	Segment group 1	C	2
0060	RFF Reference	M	1
0070	DTM Date/time/period	C	1
0080	Segment group 2	C	5
0090	FII Financial institution information	M	1
0100	CTA Contact information	C	1
0110	COM Communication contact	C	5
0120	Segment group 3	C	3
0130	NAD Name and address	M	1
0140	CTA Contact information	C	1
0150	COM Communication contact	C	5
0160	Segment group 4	M	9999
0170	LIN Line item	M	1
0180	DTM Date/time/period	C	2
0190	BUS Business function	C	1
0200	MOA Monetary amount	M	2
0210	Segment group 5	M	3
0220	RFF Reference	M	1
0230	DTM Date/time/period	C	1
0240	Segment group 6	M	1
0250	FII Financial institution information	M	1
0260	CTA Contact information	C	1
0270	COM Communication contact	C	5

0280	—— Segment group 7	C	5
0290	FCA Financial charges allocation	M	1
0300	MOA Monetary amount	C	2
0310	—— Segment group 8	C	6
0320	ALC Allowance or charge	M	1
0330	PCD Percentage details	C	1
0340	MOA Monetary amount	C	2
0350	CUX Currencies	C	1
0360	DTM Date/time/period	C	1
0370	—— Segment group 9	C	5
0380	TAX Duty/tax/fee details	M	1
0390	MOA Monetary amount	C	2
0400	CUX Currencies	C	1
0410	DTM Date/time/period	C	1
0420	—— Segment group 10	M	9999
0430	SEQ Sequence details	M	1
0440	DTM Date/time/period	C	3
0450	BUS Business function	C	1
0460	FII Financial institution information	M	2
0470	—— Segment group 11	C	5
0480	RFF Reference	M	1
0490	DTM Date/time/period	C	1
0500	—— Segment group 12	C	1
0510	PAI Payment instructions	M	1
0520	FTX Free text	C	1
0530	—— Segment group 13	M	4
0540	MOA Monetary amount	M	1
0550	CUX Currencies	C	1
0560	DTM Date/time/period	C	2
0570	RFF Reference	C	1
0580	—— Segment group 14	C	3
0590	NAD Name and address	M	1

0600	CTA Contact information	C	1
0610	COM Communication contact	C	5
0620	—— Segment group 15	C	3
0630	INP Parties to instruction	M	1
0640	FTX Free text	C	1
0650	DTM Date/time/period	C	1
0660	—— Segment group 16	C	10
0670	GIS General indicator	M	1
0680	MOA Monetary amount	C	1
0690	LOC Place/location identification	C	2
0700	NAD Name and address	C	1
0710	RCS Requirements and conditions	C	1
0720	FTX Free text	C	10
0730	—— Segment group 17	C	5
0740	FCA Financial charges allocation	M	1
0750	MOA Monetary amount	C	2
0760	—— Segment group 18	C	20
0770	ALC Allowance or charge	M	1
0780	PCD Percentage details	C	1
0790	MOA Monetary amount	C	2
0800	CUX Currencies	C	1
0810	DTM Date/time/period	C	2
0820	—— Segment group 19	C	5
0830	TAX Duty/tax/fee details	M	1
0840	MOA Monetary amount	C	2
0850	CUX Currencies	C	1
0860	DTM Date/time/period	C	1
0870	—— Segment group 20	C	1
0880	PRC Process identification	M	1
0890	FTX Free text	C	5
0900	—— Segment group 21	C	9999
0910	DOC Document/message details	M	1
0920	MOA Monetary amount	C	5

0930	DTM	Date/time/period	C	5	
0940	RFF	Reference	C	5	
0950	NAD	Name and address	C	2	
0960		Segment group 22	C	5	
0970	CUX	Currencies	M	1	
0980	DTM	Date/time/period	C	1	
0990		Segment group 23	C	100	
1000	AJT	Adjustment details	M	1	
1010	MOA	Monetary amount	C	1	
1020	RFF	Reference	C	1	
1030	FTX	Free text	C	5	

The UN EDIFACT structure shows the FTX segment at Pos. 1030 as part of SG21 (see original segment listing below). However, this is inconsistent with all other financial messages. Therefore it has been decided to treat this FTX segment as part of SG23 as in all other financial messages.

1020	RFF	Reference	C	1	
1030	FTX	Free text	C	5	

1040		Segment group 24	C	9999	
1050	DLI	Document line identification	M	1	
1060	MOA	Monetary amount	C	5	
1070	PIA	Additional product id	C	5	
1080	DTM	Date/time/period	C	5	
1090		Segment group 25	C	5	
1100	CUX	Currencies	M	1	
1110	DTM	Date/time/period	C	1	
1120		Segment group 26	C	10	
1130	AJT	Adjustment details	M	1	
1140	MOA	Monetary amount	C	1	
1150	RFF	Reference	C	1	
1160	FTX	Free text	C	5	
1170		Segment group 27	C	1	
1180	GIS	General indicator	M	1	
1190	MOA	Monetary amount	C	5	

1200	CNT Control total	C	5
1210	—— Segment group 28 ———	C	5
1220	AUT Authentication result	M	1
1230	DTM Date/time/period	C	1
1240	UNT Message trailer	M	1

3. Segment Layout

3.1. Introduction

This section describes each segment of the UN/EDIFACT message CREMUL.

Each segment is presented in a separate table and in the sequence in which they appear in the message.

The upper half of each table provides information about the segment or segment group concerned, the lower part of the table describes the data elements (composite and simple).

Each table is structured in three vertical blocks: UN/EDIFACT Directory 96.A, D6 and an empty block:

3.1.1. UN/EDIFACT Directory 96.A Block

The left third of the table provides information extracted from the original UN/EDIFACT Directory 96.A.

In the first line of this block, the segment or segment group tag is followed by the maximum number of occurrences.

The second line contains the (M)andatory / (C)onditional indicator at segment level, according to the UN/EDIFACT Directory 96.A

In the lower half of the table, the data element tag (composite or simple) and full name are followed by the corresponding (M)andatory / (C)onditional indicators and the format.

3.1.2. D6 Description Block

This block presents the recommendations of D6 (EWG sub-working group Finance).

Both for segment level and for data element level (simple and composite), the following status/sub-status are defined:

M	MANDATORY	The entity is mandatory and must be sent (according to directory, unchanged)
R	REQUIRED	The entity is required and must be sent
D	DEPENDENT	The entity must be sent in certain conditions, as defined by the relevant explanatory note

O	OPTIONAL	The entity is optional and may be sent at the discretion of the user
N	NOT USED	The entity is not used and should be omitted. Any data placed in an element marked with N will be ignored.

At data element level:

- The first column indicates the status as defined above (with the options M, R, D, O, N);
- The second column includes information affecting the code values as follows:

*	Restricted codelist	Code values preceded by an asterisk (*) are the only codes available for use in the given context
<blank>	Open codelist	Code values not preceded by an asterisk (*) are not restricted (they are open). The available codes are listed in the codelist of the corresponding UN/EDIFACT directory.
* R	Required code in a restricted list	Codes preceded by an "R" are required and must occur in one repetition of the corresponding segment if used.
R	Required code in an open list	Codes preceded by an "R" are required and must occur in one repetition of the corresponding segment if used.

- The third column provides additional comments and descriptions.

Note that if a segment group/segment/composite data element is flagged as "N", all data elements within that segment group/segment/composite data element will have blank status indicators.

3.1.3. CRG Description Block

The last block of the table describes the preferred use of the message for a group of multinational companies constituting the "Corporate Reference Group" (CRG). The CRG is established as a forum for discussions of standardisation issues. The members of the group are predominantly companies with activities in several countries and a large resource base.

3.2. Segment Description

See next page

UNH - 1 MESSAGE HEADER						
UN/EDIFACT Directory 96.A M		D6 M			CRG M	
<p>A service segment starting and uniquely identifying a message. The message type code for the Multiple credit advice message is CREMUL.</p> <p>Note: Multiple credit advice messages conforming to this document must contain the following data in segment UNH, composite S009: Data element 0065 CREMUL 0052 D 0054 96A 0051 UN</p>						
Segment number : 1						
UN/EDIFACT Directory 96.A		D6 Description			CRG Description	
0062 Message reference number	M an..14	M		This sender-generated sequence number must be unique within an interchange. DE 0062 in the UNT segment must have the same value.		
S009 MESSAGE IDENTIFIER	M	M		Incorrect data in this composite DE will cause message rejection.		
0065 Message type identifier	M an..6	M	*R	CREMUL = Multiple credit advice message		
0052 Message type version number	M an..3	M	*R	D = Directory		
0054 Message type release number	M an..3	M	*R	96A = Release 96A		
0051 Controlling agency	M an..2	M	*R	UN = UN/ECE/TRADE/WP.4, United Nations Standard Messages (UNSM)		
0057 Association assigned code	C an..6	O	*	FUN01G = Industry/ Country Code/ Version number/ Function, i.e., Finance/ United Nations/ Version 1/ General		
0068 Common access reference	C an..35	N				
S010 STATUS OF THE TRANSFER	C	N				
0070 Sequence message transfer number	M n..2					
0073 First/last sequence message transfer indication	C a1					
<u>Example:</u> UNH+19970630MJRF+CREMUL:D:96A:UN:FUN01G'						

BGM - 1 Beginning of message						
UN/EDIFACT Directory 96.A M			D6 M		CRG M	
A segment by means of which the sender must uniquely identify the CREMUL message using its type and number and its function. It is an information of items advised in advance, of items pending to be booked or of items which have been booked.						
Segment number : 2						
UN/EDIFACT Directory 96.A			D6 Description		CRG Description	
C002 Document/message name	C	R				
1001 Document/message name, coded	C an..3	R	*	454 = Credit advice		
			*	342 = Pre-advising transactions		
1131 Code list qualifier	C an..3	N				
3055 Code list responsible agency, coded	C an..3	N				
1000 Document/message name	C an..35	N				
1004 Document/message number	C an..35	R		Must be unique within the legally binding time of archiving EDI documents. A second CREMUL message with the same document number but without the code 7 in DE 1225 will be rejected.		
1225 Message function, coded	C an..3	R	*	9 = Original		Only use code 9
			*	7 = Duplicate		
4343 Response type, coded	C an..3	N		If code 7 is used, then segment group 1 is required.		
<u>Example:</u>						
BGM+454+3739824950+9'						

DTM - 1 Date/time/period						
UN/EDIFACT Directory 96.A C			D6 R		CRG R	
A segment specifying the date and, if required, the time the message is created.						
Segment number : 3						
UN/EDIFACT Directory 96.A			D6 Description		CRG Description	
C507	Date/time/period	M	M			
2005	Date/time/period qualifier	M an..3	M	*R	137 = Document/message date/time	
2380	Date/time/period	C an..35	R		A date in the future can be accepted given the creation of messages across different time zones.	
2379	Date/time/period format qualifier	C an..3	R	*	102 = CCYYMMDD	Only use code 102
				*	203 = CCYYMMDDHHMM	
<u>Example:</u>						
DTM+137:19970630:102'						

BUS - 1 Business function		
UN/EDIFACT Directory 96.A C	D6 N	CRG N
A segment identifying certain characteristics of the Multiple Credit Advice, such as, its business function. In so doing, it provides information about the message that may be used to route the message within an institution, for tariffing, or for the provision of some statistical information.		
Segment number : 4		
UN/EDIFACT Directory 96.A	D6 Description	CRG Description
C521 Business function	C	
4027 Business function qualifier	M an..3	
4025 Business function, coded	M an..3	
1131 Code list qualifier	C an..3	
3055 Code list responsible agency, coded	C an..3	
4022 Business description	C an..70	
3279 Geographic environment, coded	C an..3	
4487 Type of financial transaction, coded	C an..3	
C551 Bank operation	C	
4383 Bank operation, coded	M an..3	
1131 Code list qualifier	C an..3	
3055 Code list responsible agency, coded	C an..3	
4463 Intra-company payment, coded	C an..3	

SG1 - 2 RFF-DTM				
UN/EDIFACT Directory 96.A C		D6 D		CRG N
A group of segments identifying a previously-sent message.		This segment group is used only when DE1225 in BGM contains the code 7 (duplicate).		
RFF - 1 Reference				
UN/EDIFACT Directory 96.A M		D6 M		CRG N
A segment specifying the reference of the previously-sent message.		This segment contains the original BGM number of the previously sent message regardless of whether the two BGM numbers are the same.		
Segment number : 5				
UN/EDIFACT Directory 96.A		D6 Description		CRG Description
C506 Reference	M	M		
1153 Reference qualifier	M an..3	M	*R	ACW = Reference number to previous message BGM 1004 from the original message.
1154 Reference number	C an..35	R		
1156 Line number	C an..6	N		
4000 Reference version number	C an..35	N		
<u>Example:</u> RFF+ACW:3747837750'				

SG1 - 2 RFF-DTM					
DTM - 1 Date/time/period					
UN/EDIFACT Directory 96.A C			D6 O		CRG N
A segment identifying the creation date/time of the referenced message.					
Segment number : 6					
UN/EDIFACT Directory 96.A			D6 Description		CRG Description
C507	Date/time/period	M	M		
2005	Date/time/period qualifier	M an..3	M	*R	171 = Reference date/time
2380	Date/time/period	C an..35	R		Creation date of the original message.
2379	Date/time/period format qualifier	C an..3	R	*	102 = CCYYMMDD
				*	203 = CCYYMMDDHHMM
<u>Example:</u>					
DTM+171:19970528:102'					

SG2 - 5 FII-CTA-COM			
UN/EDIFACT Directory 96.A C	D6 O	CRG N	
A group of segments identifying the financial institutions involved in the multiple credit advice, their function and their contacts.	This segment group is used for routing purposes.		
FII - 1 Financial institution information			
UN/EDIFACT Directory 96.A M	D6 M	CRG N	
A segment identifying the financial institutions associated with the transaction, in coded or uncoded form and their function.			
Segment number : 7			
UN/EDIFACT Directory 96.A	D6 Description		CRG Description
3035 Party qualifier	M an..3	M * * *	MS = Document/message issuer/sender MR = Message Recipient AS= Account servicing financial institution. The usage of this code is subject to national agreement.
C078 Account identification	C	N	
3194 Account holder number	C an..35		
3192 Account holder name	C an..35		
3192 Account holder name	C an..35		
6345 Currency, coded	C an..3		
C088 Institution identification	C	R	The Bank Identifier Code may only be placed in DE 3433. The national bank/branch sorting code may only be placed in DE 3434. DEs 3433 and 3434 are mutually exclusive.
3433 Institution name identification	C an..11	D	
1131 Code list qualifier	C an..3	D *R	25 = Bank identification
3055 Code list responsible agency, coded	C an..3	D *R	5 = ISO (International Organization for Standardization)
3434 Institution branch number	C an..17	D	
1131 Code list qualifier	C an..3	D *	The allowed combinations of the codes of DE1131 and 3055 are stated in Section 1.5. of this MIG.
3055 Code list responsible agency, coded	C an..3	D *	The allowed combinations of the codes of DE1131 and 3055 are stated in Section 1.5. of this MIG.
3432 Institution name	C an..70	N	
3436 Institution branch place	C an..70	N	
3207 Country, coded	C an..3	D	This data element is used when DE 3434 is used and no country is mentioned in its associated DE 3055. ISO 3166 two alpha country code.
<u>Example:</u>			
FII+MS++DRESDEFF:25:5'			

SG2 - 5 FII-CTA-COM			
CTA - 1 Contact information			
UN/EDIFACT Directory 96.A C		D6 N	
A segment identifying a person or a department for the party specified in the leading FII segment to whom communication should be directed.		CRG N	
Segment number : 8			
UN/EDIFACT Directory 96.A		D6 Description	
CRG Description			
3139 Contact function, coded	C an..3		
C056 Department or employee details	C		
3413 Department or employee identification	C an..17		
3412 Department or employee	C an..35		

SG2 - 5 FII-CTA-COM			
COM - 5 Communication contact			
UN/EDIFACT Directory 96.A C		D6 N	
A segment identifying communication type (s) and number (s) of person(s) or department (s) specified in the associated CTA segment.		CRG N	
Segment number : 9			
UN/EDIFACT Directory 96.A		D6 Description	
C076 Communication contact		CRG Description	
3148 Communication number	M M an..512		
3155 Communication channel qualifier	M an..3		

SG3 - 3 NAD-CTA-COM				
UN/EDIFACT Directory 96.A C		D6 O		CRG N
A group of segments identifying the name(s) and address(es) of non-financial parties involved in the transaction, their function and their contacts.		This segment group is used for routing purposes only.		
NAD - 1 Name and address				
UN/EDIFACT Directory 96.A M		D6 M		CRG N
A segment identifying the names and addresses of the non-financial parties associated with the multiple credit advice, in coded or uncoded form, and their function.				
Segment number : 10				
EDIFACT		D6 Description		CRG Description
3035 Party qualifier	M an..3	M	* *	MR = Message receiver HQ = Account owner. The usage of this code is subject to national agreement.
C082 Party identification details	C	D		Either C082 or DE's C080, C059, 3164, 3229, 3251 and 3207 are used. In this composite only bilaterally agreed codes are allowed.
3039 Party id. identification	M an..35	M		
1131 Code list qualifier	C an..3	D		
3055 Code list responsible agency, coded	C an..3	D		
C058 Name and address	C	N		
3124 Name and address line	M an..35			
3124 Name and address line	C an..35			
3124 Name and address line	C an..35			
3124 Name and address line	C an..35			
3124 Name and address line	C an..35			
C080 Party name	C	D		Either C082 or DE's C080, C059, 3164, 3229, 3251 and 3207 are used. Use of structured name and address has to be allowed by bilateral agreement.
3036 Party name	M an..35	M		
3036 Party name	C an..35	O		
3036 Party name	C an..35	O		
3036 Party name	C an..35	N		
3036 Party name	C an..35	N		
3045 Party name format, coded	C an..3	N		
C059 Street	C	D		
3042 Street and number/p.o. box	M an..35	M		
3042 Street and number/p.o. box	C an..35	O		
3042 Street and number/p.o. box	C an..35	O		

3042	Street and number/p.o. box	C an..35	N			
3164	City name	C an..35	D			
3229	Country sub-entity Identification	C an..9	D			
3251	Postcode identification	C an..9	D			
3207	Country, coded	C an..3	D		ISO 3166 two alpha country code.	
<u>Example:</u>						
NAD+MR+2729712345832;160;9'						

SG3 - 3 NAD-CTA-COM				
CTA - 1 Contact information				
UN/EDIFACT Directory 96.A C		D6 O		CRG N
A segment identifying a person or a department for the party specified in the leading NAD segment to whom communication should be directed.				
Segment number : 11				
UN/EDIFACT Directory 96.A		D6 Description		CRG Description
3139 Contact function, coded	C an..3	R	*R	IC = Information contact
C056 Department or employee details	C	R		
3413 Department or employee identification	C an..17	N		
3412 Department or employee	C an..35	R		The name of the department or employee in free text form.
<u>Example:</u> CTA+IC+:JIM JOHNSON'				

SG3 - 3 NAD-CTA-COM					
COM - 5 Communication contact					
UN/EDIFACT Directory 96.A C			D6 O		CRG N
A segment identifying communication type(s) and number (s) of person(s) or department (s) specified in the associated CTA segment.					
Segment number : 12					
UN/EDIFACT Directory 96.A			D6 Description		CRG Description
C076 Communication contact	M	M			
3148 Communication number	M an..512	M		When character sets UNOA or UNOB are used, the @ in e-mail addresses must be shown with (at) (parenthesis, at, parenthesis), e.g. <john.smith(at)abc.com>. FX = Telefax TE = Telephone EM = Electronic mail TL = Telex The use of other codes must be bilaterally agreed.	
3155 Communication channel qualifier	M an..3	M			
<u>Example:</u> COM+496926050:TE'					

SG4 - 9999 LIN-DTM-BUS-MOA-SG5-SG6-SG7-SG10						
UN/EDIFACT Directory 96.A M		D6 M			CRG M	
A group of segments containing information details which are relevant to all transactions specified in the message.		One B level corresponds to one entry on the account.				
LIN - 1 Line item						
UN/EDIFACT Directory 96.A M		D6 M			CRG M	
A segment indicating, by a sequential line number, the beginning of the specification of details related to all transactions specified.						
Segment number : 13						
UN/EDIFACT Directory 96.A		D6 Description			CRG Description	
1082	Line item number	C n..6	R			
1229	Action request/notification, coded	C an..3	O	* *	106 = Advice without details. 107 = Advice with details.	N Not used.
C212	Item number identification	C	N			
7140	Item number	C an..35				
7143	Item number type, coded	C an..3				
1131	Code list qualifier	C an..3				
3055	Code list responsible agency, coded	C an..3				
C829	Sub-line information	C	N			
5495	Sub-line indicator, coded	C an..3				
1082	Line item number	C n..6				
1222	Configuration level	C n..2	N			
7083	Configuration, coded	C an..3	N			
<u>Example:</u>						
LIN+1'						

SG4 - 9999 LIN-DTM-BUS-MOA-SG5-SG6-SG7-SG10					
DTM - 2 Date/time/period					
UN/EDIFACT Directory 96.A C			D6 R		CRG R
A segment specifying the entry and/or value date.					
Segment number : 14					
UN/EDIFACT Directory 96.A			D6 Description		CRG Description
C507 Date/time/period	M	M			
2005 Date/time/period qualifier	M an..3	M	*	202 = Posting date	Due to the repetition factor 2 of this segment CRG only uses codes 202 and 209 here. A possible code 36 should be used on C-level.
			*	209 = Value date	
			*	455 = Expected Value Date (only used with code 342 in DE 1001 in BGM)	
2380 Date/time/period	C an..35	R			
2379 Date/time/period format qualifier	C an..3	R	*R	102 = CCYYMMDD	
<u>Example:</u>					
DTM+202:19970630:102'					

SG4 - 9999 LIN-DTM-BUS-MOA-SG5-SG6-SG7-SG10			
BUS - 1 Business function			
UN/EDIFACT Directory 96.A C		D6 O	
A segment identifying certain characteristics of the credits stored as individual transactions in level C, such as the bank operation, i.e., the method of transferring the funds, in order to sort the dependent credits according to their category.		CRG N	
Segment number : 15			
UN/EDIFACT Directory 96.A		D6 Description	
CRG Description			
C521 Business function	C	O	This composite is mutually exclusive with the same composite in BUS, SG10.
4027 Business function qualifier	M an..3	M *R	1 = Underlying business function
4025 Business function, coded	M an..3	M	
1131 Code list qualifier	C an..3	O	
3055 Code list responsible agency, coded	C an..3	O	
4022 Business description	C an..70	O	
3279 Geographic environment, coded	C an..3	R *	DO = Domestic
		*	IN = International
		*	DR = Domestic with regulatory information required
		*	IS = European Union - ECBS payments/direct debits compliant with EBS-200 (ECBS).
		*	IR = International with regulatory information required
4487 Type of financial transaction, coded	C an..3	O *	1 = Clean payment
		*	4 = Documentary payment
C551 Bank operation	C	D	This composite is mutually exclusive with the same composite in BUS, SG10.
4383 Bank operation, coded	M an..3	M	
1131 Code list qualifier	C an..3	O	
3055 Code list responsible agency, coded	C an..3	O	
4463 Intra-company payment, coded	C an..3	O	1 = Intracompany payment
<u>Example:</u>			
BUS++IN++TRF'			

SG4 - 9999 LIN-DTM-BUS-MOA-SG5-SG6-SG7-SG10			
MOA - 2 Monetary amount			
UN/EDIFACT Directory 96.A M		D6 M	
A segment specifying the total amount of all credits stored as individual transactions in level C and/or the total amount of all credits stored in level C plus the total fee amount.		CRG M	
Segment number : 16			
UN/EDIFACT Directory 96.A		D6 Description	
CRG Description			
C516 Monetary amount	M	M	
5025 Monetary amount type qualifier	M an..3	M	* * 60 = final (posted) amount XB5 = Amount for information (D6 code) – used only in pre-advising transactions.
5004 Monetary amount	C n..18	R	
6345 Currency, coded	C an..3	R	ISO 4217 currency code.
6343 Currency qualifier	C an..3	N	
4405 Status, coded	C an..3	N	
<u>Example:</u> MOA+60:45000:EUR'			

SG4 - 9999 LIN-DTM-BUS-MOA-SG5-SG6-SG7-SG10				
SG5 - 3 RFF-DTM				
UN/EDIFACT Directory 96.A M		D6 M		CRG M
A segment group containing references related to the payments, as well as relevant dates.				
RFF - 1 Reference				
UN/EDIFACT Directory 96.A M		D6 M		CRG M
A segment specifying reference numbers for the payments involved in the transaction.				
Segment number : 17				
UN/EDIFACT Directory 96.A		D6 Description		CRG Description
C506 Reference	M	M		
1153 Reference qualifier	M an..3	M	*R	ACK = Bank reference - The same reference is used in the financial statement for reconciliation purposes. AKJ = direct debit reference For more information see D6 Referencing Rules and Recommendations. This primarily restricted code list applies for international and domestic transactions. Additional domestic rules may apply. This reference number is unique during the legally binding archiving time period.
1154 Reference number	C an..35	R	*	
1156 Line number	C an..6	N		
4000 Reference version number	C an..35	N		
<u>Example:</u> RFF+ACK:48204'				

SG4 - 9999 LIN-DTM-BUS-MOA-SG5-SG6-SG7-SG10					
SG5 - 3 RFF-DTM					
DTM - 1 Date/time/period					
UN/EDIFACT Directory 96.A C			D6 O		CRG N
A segment specifying dates relevant to the related references.					
Segment number : 18					
UN/EDIFACT Directory 96.A			D6 Description		CRG Description
C507	Date/time/period	M	M		
2005	Date/time/period qualifier	M an..3	M	*R	171 = Reference date/time
2380	Date/time/period	C an..35	R		
2379	Date/time/period format qualifier	C an..3	R	*R	102 = CCYYMMDD
<u>Example:</u>					
DTM+171:19970630:102'					

Example:

FII+BF+78520739:J SMITH::USD+DRESDEFF:25:5+DE'

SG4 - 9999 LIN-DTM-BUS-MOA-SG5-SG6-SG7-SG10			
SG6 - 1 FII-CTA-COM			
CTA - 1 Contact information			
UN/EDIFACT Directory 96.A C		D6 N	CRG N
A segment identifying a person or a department for the financial institution specified in the leading FII segment to whom communication should be directed.			
Segment number : 20			
UN/EDIFACT Directory 96.A		D6 Description	CRG Description
3139 Contact function, coded	C an..3		
C056 Department or employee details	C		
3413 Department or employee identification	C an..17		
3412 Department or employee	C an..35		

SG4 - 9999 LIN-DTM-BUS-MOA-SG5-SG6-SG7-SG10			
SG6 - 1 FII-CTA-COM			
COM - 5 Communication contact			
UN/EDIFACT Directory 96.A C		D6 N	
UN/EDIFACT Directory 96.A C		CRG N	
A segment identifying communication type(s) and number(s) of person(s) or department(s) specified in the associated CTA segment.			
Segment number : 21			
UN/EDIFACT Directory 96.A		D6 Description	
UN/EDIFACT Directory 96.A		CRG Description	
C076	Communication contact	M	
3148	Communication number	M an..512	
3155	Communication channel qualifier	M an..3	

SG4 - 9999 LIN-DTM-BUS-MOA-SG5-SG6-SG7-SG10			
SG7 - 5 FCA-MOA-SG8			
UN/EDIFACT Directory 96.A C		D6 D	
A group of segments providing full details of all charges or allowances, and associated taxes, that apply to the total amount, together with information as to who bears the charges and to which account they have been directed. Where charges are subject to taxation this may also be specified.		Option 1: Neither SG07 nor SG17 are used (no charges or allowances). Option 2: SG07 alone is used when the amount of charges or allowances is calculated from MOA segment, SG07, with qualifier 25 in DE 5025. Option 3: SG17 is used. The single amounts in SG17 have to be summed up into SG07 when charges/allowances are not included in the transaction. This option only uses code 7 in DE 4471.	
FCA - 1 Financial charges allocation			
UN/EDIFACT Directory 96.A M		D6 M	
A segment specifying the method for allocation of charges and allowances and identifying an account to which such charges or allowances were directed where it is different from the principal account.			
Segment number : 22			
UN/EDIFACT Directory 96.A		D6 Description	
CRG Description			
4471 Settlement, coded	M an..3	M *	7 = Optional - used only with option 3; charge details to be provided in level C. * 13 = All charges borne by payee (or beneficiary) * 14 = Each pay own cost * 15 = All charges borne by payor
C878 Charge/allowance account	C	O	If no account is mentioned, charges will be booked according to bilateral agreement.
3434 Institution branch number	M an..17	M	National identification of the financial institution in coded form.
1131 Code list qualifier	C an..3	R *	The allowed combinations of the codes of DE1131 and 3055 are stated in Section 1.5. of this MIG.
3055 Code list responsible agency, coded	C an..3	R *	The allowed combinations of the codes of DE1131 and 3055 are stated in Section 1.5. of this MIG.
3194 Account holder number	C an..35	R	
6345 Currency, coded	C an..3	O	ISO 4217 three alpha currency code
<u>Example:</u> FCA+13'			

SG4 - 9999 LIN-DTM-BUS-MOA-SG5-SG6-SG7-SG10			
SG7 - 5 FCA-MOA-SG8			
MOA - 2 Monetary amount			
UN/EDIFACT Directory 96.A C		D6 D	
A segment identifying the basis amount from which charges are calculated, if different from the total amount. It is also giving the total value of charges and/or allowances, and associated taxes.		This segment is only used when the amount of charges or allowances affects the account holder.	
Segment number : 23			
UN/EDIFACT Directory 96.A		D6 Description	
CRG Description			
C516 Monetary amount	M	M	
5025 Monetary amount type qualifier	M an..3	M	* 488 = Total charges, not included in the transaction amount
			* 489 = Total allowances, not included in the transaction amount
			* 259 = Total charges - included in the transaction amount.
			* 260 = Total allowances - included in the transaction amount.
			* 25 = Charge/allowance basis - this code is only used with option 2 in FCA segment, SG07.
5004 Monetary amount	C n..18	R	
6345 Currency, coded	C an..3	R	ISO 4217 currency code.
6343 Currency qualifier	C an..3	N	
4405 Status, coded	C an..3	N	
<u>Example:</u> MOA+259:180:EUR'			

SG4 - 9999 LIN-DTM-BUS-MOA-SG5-SG6-SG7-SG10				
SG7 - 5 FCA-MOA-SG8				
SG8 - 6 ALC-PCD-MOA-CUX-DTM-SG9				
UN/EDIFACT Directory 96.A C		D6 D		
A group of segments providing a detailed breakdown of all charges (or allowances) and associated charges (or allowances).		This segment group can only be used with option 2 in FCA segment, SG07.		
ALC - 1 Allowance or charge				
UN/EDIFACT Directory 96.A M		D6 M		
A segment used to provide full details of each charge or allowance for which the Payee is liable. Included are full details of the method of calculating the charge.				
Segment number : 24				
UN/EDIFACT Directory 96.A		D6 Description		
5463 Allowance or charge qualifier M an..3		M	* *	
C552 Allowance/charge information C		O	A = Allowance C = Charge	
1230 Allowance or charge number C an..35		O	Identification of allowance/charge information relating to the amount.	
5189 Charge/allowance description, coded C an..3		R		
4471 Settlement, coded C an..3		N		
1227 Calculation sequence indicator, coded C an..3		N		
C214 Special services identification C		O		
7161 Special services, coded C an..3		O		
1131 Code list qualifier C an..3		O		
3055 Code list responsible agency, coded C an..3		O		
7160 Special service C an..35		O		
7160 Special service C an..35		O		
<u>Example:</u> ALC+C+:55'				

SG4 - 9999 LIN-DTM-BUS-MOA-SG5-SG6-SG7-SG10						
SG7 - 5 FCA-MOA-SG8						
SG8 - 6 ALC-PCD-MOA-CUX-DTM-SG9						
PCD - 1 Percentage details						
UN/EDIFACT Directory 96.A C			D6 O		CRG N	
A segment specifying the percentage used for calculating the charges (or allowances).			This segment is used if the calculation of the amount is based on a percentage.			
Segment number : 25						
UN/EDIFACT Directory 96.A			D6 Description		CRG Description	
C501 Percentage details	M	M		3 = Allowance or charge Specification of the percentage set; a value of zero is not permitted.		
5245 Percentage qualifier	M an..3	M				
5482 Percentage	C n..10	R				
5249 Percentage basis, coded	C an..3	N				
1131 Code list qualifier	C an..3	N				
3055 Code list responsible agency, coded	C an..3	N				
<u>Example:</u> PCD+3:0,4'						

SG4 - 9999 LIN-DTM-BUS-MOA-SG5-SG6-SG7-SG10			
SG7 - 5 FCA-MOA-SG8			
SG8 - 6 ALC-PCD-MOA-CUX-DTM-SG9			
MOA - 2 Monetary amount			
UN/EDIFACT Directory 96.A C		D6 R	
A segment identifying the amount of charges (or allowances) and/or specifying the basis amount from which charges (or allowances) may be calculated if different from the MOA segment.		A segment identifying the amount of charges (or allowances) and/or specifying the basis amount from which charges (or allowances) may be calculated if different from the MOA segment in SG7.	
Segment number : 26			
UN/EDIFACT Directory 96.A		D6 Description	
C516 Monetary amount			
5025 Monetary amount type qualifier	M M an..3	M M	<p>The meaning of the codes must be identical to those in the ALC and PCD segments.</p> <ul style="list-style-type: none"> * 23 = Charge amount * 25 = Charge/allowance basis - the basis must be different to that contained in MOA in segment group 7 * 204 = Allowance amount <p>This data element is mandatory if an amount is calculated or if a basis is quoted. This data element is not used if code 18 (free of charge) is used in DE 4405.</p> <p>ISO 4217 three alpha currency code. This DE is only used when DE 5004 is used.</p> <p>This DE must not be used if code 25 is used in DE 5025.</p> <ul style="list-style-type: none"> * 6 = Minimum * 7 = Fixed * 8 = Maximum * 9 = Information – this code is not used if code 259 or 260 are used in DE 5025, MOA segment, SG07. * 18 = Free of charge - there is no amount in data element 5004. * 19 = Rounded - the absence of this data element means that the amount is exactly as calculated .
5004 Monetary amount	C n..18	D	
6345 Currency, coded	C an..3	D	
6343 Currency qualifier	C an..3	N	
4405 Status, coded	C an..3	D	
<u>Example:</u>			
MOA+23:150:EUR::7'			

SG4 - 9999 LIN-DTM-BUS-MOA-SG5-SG6-SG7-SG10		
SG7 - 5 FCA-MOA-SG8		
SG8 - 6 ALC-PCD-MOA-CUX-DTM-SG9		
CUX - 1 Currencies		
UN/EDIFACT Directory 96.A C	D6 N	CRG N
A segment specifying rates related to the charges and allowances.		
Segment number : 27		
UN/EDIFACT Directory 96.A	D6 Description	CRG Description
C504 Currency details	C	
6347 Currency details qualifier	M an..3	
6345 Currency, coded	C an..3	
6343 Currency qualifier	C an..3	
6348 Currency rate base	C n..4	
C504 Currency details	C	
6347 Currency details qualifier	M an..3	
6345 Currency, coded	C an..3	
6343 Currency qualifier	C an..3	
6348 Currency rate base	C n..4	
5402 Rate of exchange	C n..12	
6341 Currency market exchange, coded	C an..3	

SG4 - 9999 LIN-DTM-BUS-MOA-SG5-SG6-SG7-SG10			
SG7 - 5 FCA-MOA-SG8			
SG8 - 6 ALC-PCD-MOA-CUX-DTM-SG9			
DTM - 1 Date/time/period			
UN/EDIFACT Directory 96.A C	D6	N	CRG N
A segment identifying the effective date and/or time the rate of exchange was fixed.			
Segment number : 28			
UN/EDIFACT Directory 96.A	D6 Description		CRG Description
C507 Date/time/period	M		
2005 Date/time/period qualifier	M an..3		
2380 Date/time/period	C an..35		
2379 Date/time/period format qualifier	C an..3		

SG4 - 9999 LIN-DTM-BUS-MOA-SG5-SG6-SG7-SG10						
SG7 - 5 FCA-MOA-SG8						
SG8 - 6 ALC-PCD-MOA-CUX-DTM-SG9						
SG9 - 5 TAX-MOA-CUX-DTM						
UN/EDIFACT Directory 96.A C			D6 O		CRG N	
A group of segments describing any taxes associated with charges and their amount.						
TAX - 1 Duty/tax/fee details						
UN/EDIFACT Directory 96.A M			D6 M		CRG N	
A segment identifying any taxes related to a specific charge.						
Segment number : 29						
UN/EDIFACT Directory 96.A			D6 Description		CRG Description	
5283	Duty/tax/fee function qualifier	M an..3	M		7 = Tax	
C241	Duty/tax/fee type	C	R			
5153	Duty/tax/fee type, coded	C an..3	R		VAT = Value added tax	
1131	Code list qualifier	C an..3	N			
3055	Code list responsible agency, coded	C an..3	N			
5152	Duty/tax/fee type	C an..35	N			
C533	Duty/tax/fee account detail	C	N			
5289	Duty/tax/fee account identification	M an..6				
1131	Code list qualifier	C an..3				
3055	Code list responsible agency, coded	C an..3				
5286	Duty/tax/fee assessment basis	C an..15	N			
C243	Duty/tax/fee detail	C	R			
5279	Duty/tax/fee rate identification	C an..7	O			
1131	Code list qualifier	C an..3	O			
3055	Code list responsible agency, coded	C an..3	O			
5278	Duty/tax/fee rate	C an..17	R		The actual rate of tax/duty.	
5273	Duty/tax/fee rate basis identification	C an..12	N			
1131	Code list qualifier	C an..3	N			
3055	Code list responsible agency, coded	C an..3	N			
5305	Duty/tax/fee category, coded	C an..3	N			
3446	Party tax identification number	C an..20	O			
<u>Example:</u>						
TAX+7+VAT+++:::20++NVET0244'						

SG4 - 9999 LIN-DTM-BUS-MOA-SG5-SG6-SG7-SG10						
SG7 - 5 FCA-MOA-SG8						
SG8 - 6 ALC-PCD-MOA-CUX-DTM-SG9						
SG9 - 5 TAX-MOA-CUX-DTM						
MOA - 2 Monetary amount						
UN/EDIFACT Directory 96.A C			D6 O		CRG N	
A segment specifying the total amount of the tax and the basis of calculation.						
Segment number : 30						
UN/EDIFACT Directory 96.A			D6 Description		CRG Description	
C516 Monetary amount	M	M				
5025 Monetary amount type qualifier	M an..3	M		56 = Duty/tax/fee basis amount 124 = Tax amount 204 = Allowance amount		
5004 Monetary amount	C n..18	R				
6345 Currency, coded	C an..3	R		Only ISO codes are allowed.		
6343 Currency qualifier	C an..3	N				
4405 Status, coded	C an..3	D		The absence of this data element means that the amount in DE 5004 is the exact calculated amount. 6 = Minimum 7 = Fixed 8 = Maximum 9 = Information 19 = Rounded		
<u>Example:</u> MOA+124:30:EUR::8'						

SG4 - 9999 LIN-DTM-BUS-MOA-SG5-SG6-SG7-SG10			
SG7 - 5 FCA-MOA-SG8			
SG8 - 6 ALC-PCD-MOA-CUX-DTM-SG9			
SG9 - 5 TAX-MOA-CUX-DTM			
CUX - 1 Currencies			
UN/EDIFACT Directory 96.A C		D6 D	
A segment specifying exchange rates.		<p>The exchange rate is specified if a converted amount is in the preceding MOA segment.</p> <p><u>Calculation formula:</u> <i>Case 1) Base rate is indicated next to reference currency:</i> Converted amount = Original amount * (exchange rate / rate base) <i>Case 2) Base rate is indicated next to target currency:</i> Converted amount = Original amount / (exchange rate / rate base)</p>	
Segment number : 31			
UN/EDIFACT Directory 96.A		D6 Description	
C504 Currency details 6347 Currency details qualifier 6345 Currency, coded 6343 Currency qualifier 6348 Currency rate base		C M an..3 C an..3 C an..3 C n..4	R M R N D * * * 2 = Reference currency ISO 4217 three alpha currency code This DE is used only when an exchange rate is quoted in DE 5402. It is mutually exclusive with DE 6348 in the following C504. 1 = the rate base is 1 100 = the rate base is 100 1000 = the rate base is 1000
C504 Currency details 6347 Currency details qualifier 6345 Currency, coded 6343 Currency qualifier 6348 Currency rate base		C M an..3 C an..3 C an..3 C n..4	D M R N D * * * 3 = Target currency ISO 4217 three alpha currency code. This DE is used only when an exchange rate is quoted in DE 5402. It is mutually exclusive with DE 6348 in the previous C504. 1 = the rate base is 1 100 = the rate base is 100 1000 = the rate base is 1000
5402 Rate of exchange 6341 Currency market exchange, coded		C n..12 C an..3	O N

Example:

CUX+2:USD+3:EUR::1+1,05'

SG4 - 9999 LIN-DTM-BUS-MOA-SG5-SG6-SG7-SG10						
SG7 - 5 FCA-MOA-SG8						
SG8 - 6 ALC-PCD-MOA-CUX-DTM-SG9						
SG9 - 5 TAX-MOA-CUX-DTM						
DTM - 1 Date/time/period						
UN/EDIFACT Directory 96.A C			D6 O		CRG N	
A segment identifying the effective date and/or time the rate of exchange was fixed.						
Segment number : 32						
UN/EDIFACT Directory 96.A			D6 Description		CRG Description	
C507	Date/time/period	M	M			
2005	Date/time/period qualifier	M an..3	M		134 = Rate of exchange date/time	
2380	Date/time/period	C an..35	R			
2379	Date/time/period format qualifier	C an..3	R		102 = CCYYMMDD Code 102 is recommended. 203 = CCYYMMDDHHMM	
<u>Example:</u>						
DTM+134:19970630:102'						

SG4 - 9999 LIN-DTM-BUS-MOA-SG5-SG6-SG7-SG10			
SG10 - 9999 SEQ-DTM-BUS-FII-SG11-SG12-SG13-SG14-SG15-SG16-SG17-SG20			
UN/EDIFACT Directory 96.A M		D6 M	
A segment group providing details regarding the individual transactions, such as dates, financial institutions, account numbers.		If SG4 – LIN – DE 1229 = 106, only FII and MOA of SG13 will follow.	
SEQ - 1 Sequence details			
UN/EDIFACT DIRECTORY 96.A M		D6 M	
A segment identifying the beginning of the specification of individual transactions (C level) by a sequential number.		This is a trigger segment specifying the start of each single transaction.	
Segment number : 33			
UN/EDIFACT Directory 96.A		D6 Description	
1245 Status indicator, coded C286 Sequence information 1050 Sequence number 1159 Sequence number source, coded 1131 Code list qualifier 3055 Code list responsible agency, coded		C an..3 N C R M an..6 M C an..3 N C an..3 N C an..3 N	Application generated number of the count of the sequence in a multiple credit advice. The sequence number must be reset to one for each occurrence of a new line number (in LIN segment).
<u>Example:</u> SEQ++1'			

SG4 - 9999 LIN-DTM-BUS-MOA-SG5-SG6-SG7-SG10					
SG10 - 9999 SEQ-DTM-BUS-FII-SG11-SG12-SG13-SG14-SG15-SG16-SG17-SG20					
DTM - 3 Date/time/period					
UN/EDIFACT Directory 96.A C		D6 O		CRG O	
A segment specifying value dates and other dates passed on from a preceding payment order.		Using the same qualifiers as on level B implies same date.			
Segment number : 34					
UN/EDIFACT Directory 96.A		D6 Description			CRG Description
C507 Date/time/period	M	M			Codes 202 and 209 are not used here but on B-level only. On C-level only the additional code 36 is used.
2005 Date/time/period qualifier	M an..3	M		202 = Posting date 209 = Value date 36 = Expiry date (e.g. for Bills of Exchange) 455 = Expected Value Date (only used with code 342 in DE 1001 in BGM)	
2380 Date/time/period	C an..35	R			
2379 Date/time/period format qualifier	C an..3	R	*R	102 = CCYYMMDD	
<u>Example:</u> DTM+209:19970630:102'					

SG4 - 9999 LIN-DTM-BUS-MOA-SG5-SG6-SG7-SG10				
SG10 - 9999 SEQ-DTM-BUS-FII-SG11-SG12-SG13-SG14-SG15-SG16-SG17-SG20				
BUS - 1 Business function				
UN/EDIFACT Directory 96.A C		D6 O		
A segment specifying additional details regarding the individual credit, such as its business function.		This segment is either bank-generated or contains data from a customer order.		
Segment number : 35				
UN/EDIFACT Directory 96.A		D6 Description		
CRG Description				
C521 Business function	C	O	Mutually exclusive with SG4 – BUS – C521.	
4027 Business function qualifier	M an..3	M		
4025 Business function, coded	M an..3	M		
1131 Code list qualifier	C an..3	O		
3055 Code list responsible agency, coded	C an..3	O		
4022 Business description	C an..70	O		
3279 Geographic environment, coded	C an..3	O		
4487 Type of financial transaction, coded	C an..3	O		
C551 Bank operation	C	D		This composite is mutually exclusive with the same composite in BUS, SG04.
4383 Bank operation, coded	M an..3	M		
1131 Code list qualifier	C an..3	O		
3055 Code list responsible agency, coded	C an..3	O		
4463 Intra-company payment, coded	C an..3	O		
<u>Example:</u> BUS+1:GDS+IN+1'				

SG4 - 9999 LIN-DTM-BUS-MOA-SG5-SG6-SG7-SG10			
SG10 - 9999 SEQ-DTM-BUS-FII-SG11-SG12-SG13-SG14-SG15-SG16-SG17-SG20			
FII - 2 Financial institution information			
UN/EDIFACT Directory 96.A M		D6 M	
A segment identifying the financial institutions and relevant account number associated with the transaction, in coded or uncoded form and their function.		If code 106 is present in SG4 – LIN – DE 1229, there will only be one occurrence of FII. In this occurrence, only DE 3035 = ZZZ will be used.	
Segment number : 36			
UN/EDIFACT Directory 96.A		D6 Description	
		CRG Description	
3035 Party qualifier	M an..3	M	OR = Ordered bank BF = Beneficiary's bank (implies the same account as in FII, SG06) II = Intermediary bank 1 PH = Payor's financial institution ZZZ = Bilaterally agreed – See segment note. For more information about dependencies, refer to Section 1.4. of this MIG.
C078 Account identification	C	O	
3194 Account holder number	C an..35	R	The account number should be entered according to the national account number scheme. If an IBAN is used, it should be present in this DE.
3192 Account holder name	C an..35	D	Identifying the name and place of the account holder is mandatory in some countries. For more information about dependencies, refer to Section 1.4. of this MIG.
3192 Account holder name	C an..35	O	The account holder name (continued).
6345 Currency, coded	C an..3	O	ISO 4217 three alpha currency code if needed
C088 Institution identification	C	D	This composite DE is not needed in some countries . The Bank Identifier Code may only be placed in DE 3433. The national bank/branch sorting code may only be placed in DE 3434. The appropriate code should be used regardless of the use of the IBAN.
3433 Institution name identification	C an..11	D	International identification of the financial institution in coded form.
1131 Code list qualifier	C an..3	D *R	25 = Bank Identification
3055 Code list responsible agency, coded	C an..3	D *R	5 = ISO (International Organization for Standardization)
3434 Institution branch number	C an..17	D	National identification of the financial institution in coded form.
1131 Code list qualifier	C an..3	D *	The allowed combinations of the codes of DE1131 and 3055 are stated in Section 1.5. of this MIG.

3055 Code list responsible agency, coded	C an..3	D	*	The allowed combinations of the codes of DE1131 and 3055 are stated in Section 1.5. of this MIG.
3432 Institution name	C an..70	O		
3436 Institution branch place	C an..70	O		
3207 Country, coded	C an..3	D		ISO 3166 two alpha country code. This data element must be used unless an IBAN is included in DE3194.
<u>Example:</u>				
FII+OR+27834895:J SCHMIDT:FRANKFURT+DRESDEFF:25:5+DE'				

SG4 - 9999 LIN-DTM-BUS-MOA-SG5-SG6-SG7-SG10			
SG10 - 9999 SEQ-DTM-BUS-FII-SG11-SG12-SG13-SG14-SG15-SG16-SG17-SG20			
SG11 - 5 RFF-DTM			
UN/EDIFACT Directory 96.A C		D6 D	
A group of segments containing references of other messages and transactions, with relevant date(s)/time(s).		This SG must not be used if code 106 is present in SG04 – LIN – DE 1229. In all other cases this SG is required.	
RFF - 1 Reference			
UN/EDIFACT Directory 96.A M		D6 M	
A segment identifying references of other messages or transactions related to this transaction.			
Segment number : 37			
UN/EDIFACT Directory 96.A		D6 Description	
C506 Reference 1153 Reference qualifier		M M an..3	
1154 Reference number 1156 Line number 4000 Reference version number		M M *R * * * * * * * R N N	
		AIK = Bank's individual transaction reference number CR = Customer reference number AKJ = Direct debit reference AKN = Third bank's reference PQ = Payment reference RA = Remittance information AGB = Contract party reference number (direct debit mandate number). The usage of this code is subject to national agreement. For more information see D6 Referencing Rules and Recommendations. This primarily restricted code list applies for international and domestic transactions. Additional domestic rules may apply.	
CRG Description			
Example: RFF+AIK:423390'			

SG4 - 9999 LIN-DTM-BUS-MOA-SG5-SG6-SG7-SG10					
SG10 - 9999 SEQ-DTM-BUS-FII-SG11-SG12-SG13-SG14-SG15-SG16-SG17-SG20					
SG11 - 5 RFF-DTM					
DTM - 1 Date/time/period					
UN/EDIFACT Directory 96.A C			D6 O		CRG N
A segment specifying the date and/or time of the referenced messages or transactions.					
Segment number : 38					
UN/EDIFACT Directory 96.A			D6 Description		CRG Description
C507	Date/time/period	M	M		
2005	Date/time/period qualifier	M an..3	M	*R	171= Reference date/time
2380	Date/time/period	C an..35	R		
2379	Date/time/period format qualifier	C an..3	R	*	102 = CCYYMMDD Code 102 is recommended.
				*	203 = CCYYMMDDHHMM
<u>Example:</u>					
DTM+171:19970630:102'					

SG4 - 9999 LIN-DTM-BUS-MOA-SG5-SG6-SG7-SG10			
SG10 - 9999 SEQ-DTM-BUS-FII-SG11-SG12-SG13-SG14-SG15-SG16-SG17-SG20			
SG12 - 1 PAI-FTX			
UN/EDIFACT Directory 96.A C	D6	O	CRG N
A group of segments specifying conditions, guarantees, method and channel of payment used.			
PAI - 1 Payment instructions			
UN/EDIFACT Directory 96.A M	D6	M	CRG N
A segment specifying the conditions, guarantee, method and channel of payment used.			
Segment number : 39			
UN/EDIFACT Directory 96.A	D6 Description		CRG Description
C534 Payment instruction details	M	M	Method of payment and payment channel.
4439 Payment conditions, coded	C an..3	O	
4431 Payment guarantee, coded	C an..3	O	
4461 Payment means, coded	C an..3	O	
1131 Code list qualifier	C an..3	O	
3055 Code list responsible agency, coded	C an..3	O	
4435 Payment channel, coded	C an..3	O	
<u>Example:</u>			
PAI+::8::5'			

SG4 - 9999 LIN-DTM-BUS-MOA-SG5-SG6-SG7-SG10						
SG10 - 9999 SEQ-DTM-BUS-FII-SG11-SG12-SG13-SG14-SG15-SG16-SG17-SG20						
SG12 - 1 PAI-FTX						
FTX - 1 Free text						
UN/EDIFACT Directory 96.A C			D6 O		CRG N	
A segment providing free form additional information.						
Segment number : 40						
UN/EDIFACT Directory 96.A			D6 Description			CRG Description
4451	Text subject qualifier	M an..3	M	*R	PAI = Payment instructions information	
4453	Text function, coded	C an..3	N			
C107	Text reference	C	O		Only nationally agreed coded free text may be used.	
4441	Free text, coded	M an..3	M			
1131	Code list qualifier	C an..3	O			
3055	Code list responsible agency, coded	C an..3	O			
C108	Text literal	C	R			
4440	Free text	M an..70	M			
4440	Free text	C an..70	O			
4440	Free text	C an..70	O			
4440	Free text	C an..70	O			
4440	Free text	C an..70	O			
3453	Language, coded	C an..3	O		Only ISO codes are allowed.	
<u>Example:</u>						
FTX+PAI+++VERY IMPORTANT+EN'						

SG4 - 9999 LIN-DTM-BUS-MOA-SG5-SG6-SG7-SG10			
SG10 - 9999 SEQ-DTM-BUS-FII-SG11-SG12-SG13-SG14-SG15-SG16-SG17-SG20			
SG13 - 4 MOA-CUX-DTM-RFF			
UN/EDIFACT Directory 96.A M		D6 M	
A group of segments identifying the monetary amounts and, if necessary, the currencies, exchange rate and date for the amount of the transaction.		If code 106 is present in SG4 – LIN – DE 1229, there will only be one occurrence of SG13. In this occurrence, there will only be one MOA where DE 5025 = ZZZ.	
MOA - 1 Monetary amount			
UN/EDIFACT Directory 96.A M		D6 M	
A segment giving the amount of the individual transaction.			
Segment number : 41			
UN/EDIFACT Directory 96.A		D6 Description	
C516 Monetary amount		M	
5025 Monetary amount type qualifier	M an..3	M	* 98 = Original amount
			* 143 = Transfer amount
			* 36 = Converted amount – usage of this code implies that the CUX segment must follow
			* 60 = Posted amount
			* XB5 = Amount for information (D6 code) – used only for pre-advising transactions
			Codes 60 and XB5 are mutually exclusive.
			* ZZZ = Mutually agreed – See segment group note.
5004 Monetary amount	C n..18	D	Required unless DE 5025 = ZZZ
6345 Currency, coded	C an..3	D	ISO 4217 three alpha currency code
			Required unless DE 5025 = ZZZ
6343 Currency qualifier	C an..3	N	
4405 Status, coded	C an..3	N	
<u>Example:</u>			
MOA+60:41000:EUR'			

SG4 - 9999 LIN-DTM-BUS-MOA-SG5-SG6-SG7-SG10			
SG10 - 9999 SEQ-DTM-BUS-FII-SG11-SG12-SG13-SG14-SG15-SG16-SG17-SG20			
SG13 - 4 MOA-CUX-DTM-RFF			
CUX - 1 Currencies			
UN/EDIFACT Directory 96.A C		D6 D	
A segment identifying the source currency and the target currency of the transaction, when they are different.		<p>This segment is used if code 36 is present in DE 5025 in the previous MOA segment.</p> <p><u>Calculation formula:</u> <i>Case 1) Base rate is indicated next to reference currency:</i> Converted amount = MOA amount * (exchange rate / rate base) <i>Case 2) Base rate is indicated next to target currency:</i> Converted amount = MOA amount / (exchange rate / rate base) (where MOA amount = either Original amount or Transfer amount if present)</p>	
Segment number : 42			
UN/EDIFACT Directory 96.A		D6 Description	
C504 Currency details 6347 Currency details qualifier 6345 Currency, coded 6343 Currency qualifier 6348 Currency rate base		C R M an..3 M *R 2 = Reference currency C an..3 R ISO 4217 three alpha currency code. C an..3 N C n..4 D This DE is used only when an exchange rate is quoted in DE 5402. It is mutually exclusive with DE 6348 in the following C504. * 1 = the rate base is 1 * 100 = the rate base is 100 * 1000 = the rate base is 1000	
C504 Currency details 6347 Currency details qualifier 6345 Currency, coded 6343 Currency qualifier 6348 Currency rate base		C R M an..3 M *R 3 = Target currency C an..3 R ISO 4217 three alpha currency code. C an..3 N C n..4 D This DE is used only when an exchange rate is quoted in DE 5402. It is mutually exclusive with DE 6348 in the previous C504. * 1 = the rate base is 1 * 100 = the rate base is 100 * 1000 = the rate base is 1000	
5402 Rate of exchange		C n..12 O	

SG4 - 9999 LIN-DTM-BUS-MOA-SG5-SG6-SG7-SG10						
SG10 - 9999 SEQ-DTM-BUS-FII-SG11-SG12-SG13-SG14-SG15-SG16-SG17-SG20						
SG13 - 4 MOA-CUX-DTM-RFF						
DTM - 2 Date/time/period						
UN/EDIFACT DIRECTORY 96.A C			D6 O		CRG O	
A segment identifying the effective date and/or time the rate of exchange was fixed.						
Segment number : 43						
UN/EDIFACT Directory 96.A			D6 Description			CRG Description
C507	Date/time/period	M	M			
2005	Date/time/period qualifier	M an..3	M	*	134 = Rate of exchange date/time – this code may only be used if the previous CUX segment exists.	
				*	171 = Reference date/time – this code may only be used if the following RFF segment exists.	
2380	Date/time/period	C an..35	R		102 = CCYYMMDD	Only use code 102
2379	Date/time/period format qualifier	C an..3	R		Code 102 is recommended.	
					203 = CCYYMMDDHHMM	
<u>Example:</u>						
DTM+134:19970630:102'						

SG4 - 9999 LIN-DTM-BUS-MOA-SG5-SG6-SG7-SG10						
SG10 - 9999 SEQ-DTM-BUS-FII-SG11-SG12-SG13-SG14-SG15-SG16-SG17-SG20						
SG13 - 4 MOA-CUX-DTM-RFF						
RFF - 1 Reference						
UN/EDIFACT DIRECTORY 96.A C			D6 D		CRG D	
A segment identifying other transactions to which funds associated with the transaction is related such as a separate foreign exchange deal.			This segment must be used if the previous DTM segment contains code 171 in DE 2005. This segment may be used without the previous DTM segment.			
Segment number : 44						
UN/EDIFACT Directory 96.A			D6 Description		CRG Description	
C506 Reference			M	M		
1153 Reference qualifier	M an..3	M		FX = Foreign exchange contract number		
1154 Reference number	C an..35	R				
1156 Line number	C an..6	N				
4000 Reference version number	C an..35	N				
<u>Example:</u>						
RFF+FX:407082'						

SG4 - 9999 LIN-DTM-BUS-MOA-SG5-SG6-SG7-SG10			
SG10 - 9999 SEQ-DTM-BUS-FII-SG11-SG12-SG13-SG14-SG15-SG16-SG17-SG20			
SG14 - 3 NAD-CTA-COM			
UN/EDIFACT DIRECTORY 96.A C		D6 O	
A group of segments identifying the name and address of non-financial parties involved in the message, their function and their contacts.		This segment group is used when parties are quoted others than the account holder or additional information related to the account holder has to be provided.	
NAD - 1 Name and address			
UN/EDIFACT DIRECTORY 96.A M		D6 M	
A segment identifying the names and addresses of the parties associated with the exchange of the message, in coded or uncoded form, and their function.			
Segment number : 45			
UN/EDIFACT Directory 96.A		D6 Description	
3035 Party qualifier		M an..3	M
			BE = Beneficiary - ultimate recipient of the funds but not the account owner. Also used to indicate direct debits on behalf of subsidiaries. HX = Debtor - party from whom payment was due, but not the account owner. PE = Payee - additional information about the account owner defined in SG6 – FII with DE3035 = BF (Beneficiary's bank). OY = Ordering customer - this code is used to enable payments on behalf of subsidiaries. PL = Payor - additional information about the account owner defined in SG10 – FII with DE3035 = OR (Ordered bank) or PH (Payer's financial institution). RV = Receiver of cheque - if different from the beneficiary. For more information about dependencies, refer to Section 1.4. of this MIG.
C082 Party identification details		C	O
3039 Party id. identification		M an..35	M
1131 Code list qualifier		C an..3	O
3055 Code list responsible agency, coded		C an..3	O
C058 Name and address		C	D
3124 Name and address line		M an..35	M
			Either C058 or DE's C080, C059, 3164, 3229, 3251 and 3207 are used. Unstructured specification of the name and address is not recommended.

3124	Name and address line	C	an..35	O			
3124	Name and address line	C	an..35	O			
3124	Name and address line	C	an..35	O			
3124	Name and address line	C	an..35	O			
C080	Party name	C		D		Either C058 or DE's C080, C059, 3164, 3229, 3251 and 3207 are used.	
3036	Party name	M	an..35	M			
3036	Party name	C	an..35	O			
3036	Party name	C	an..35	O			
3036	Party name	C	an..35	O			
3036	Party name	C	an..35	O			
3045	Party name format, coded	C	an..3	O			
C059	Street	C		D			
3042	Street and number/p.o. box	M	an..35	M			
3042	Street and number/p.o. box	C	an..35	O			
3042	Street and number/p.o. box	C	an..35	O			
3042	Street and number/p.o. box	C	an..35	O			
3164	City name	C	an..35	D			
3229	Country sub-entity identification	C	an..9	D			
3251	Postcode identification	C	an..9	D			
3207	Country, coded	C	an..3	D		Country of the identified party. ISO 3166 two alpha country code.	
<u>Example:</u> NAD+OY+++MILAR COMPANY+EXAMPLE STREET 23+NORWICH++NR2 3NW+GB'							

SG4 - 9999 LIN-DTM-BUS-MOA-SG5-SG6-SG7-SG10					
SG10 - 9999 SEQ-DTM-BUS-FII-SG11-SG12-SG13-SG14-SG15-SG16-SG17-SG20					
SG14 - 3 NAD-CTA-COM					
CTA - 1 Contact information					
UN/EDIFACT Directory 96.A C		D6 O		CRG O	
A segment identifying a person or a department for the party specified in the leading NAD segment and to whom communication should be directed.					
Segment number : 46					
UN/EDIFACT Directory 96.A		D6 Description			CRG Description
3139 Contact function, coded	C an..3	R	*R	IC = Information contact	
C056 Department or employee details	C	R			
3413 Department or employee identification	C an..17	N			
3412 Department or employee	C an..35	R		The name of the department or employee in free text form.	
<u>Example:</u>					
CTA+IC+:JIM JOHNSON'					

SG4 - 9999 LIN-DTM-BUS-MOA-SG5-SG6-SG7-SG10						
SG10 - 9999 SEQ-DTM-BUS-FII-SG11-SG12-SG13-SG14-SG15-SG16-SG17-SG20						
SG14 - 3 NAD-CTA-COM						
COM - 5 Communication contact						
UN/EDIFACT Directory 96.A C			D6 O		CRG O	
A segment identifying communication type (s) and number(s) of person(s) or department (s) specified in the associated CTA segment.						
Segment number : 47						
UN/EDIFACT Directory 96.A			D6 Description		CRG Description	
C076	Communication contact	M	M		When character sets UNOA or UNOB are used, the @ in e-mail addresses must be shown with (at) (parenthesis, at, parenthesis), e.g. <john.smith(at)abc.com>. FX = Telefax TE = Telephone EM = Electronic mail TL = Telex The use of other codes must be bilaterally agreed.	
3148	Communication number	M an..512	M			
3155	Communication channel qualifier	M an..3	M			
<u>Example:</u> COM+496926050:TE'						

SG4 - 9999 LIN-DTM-BUS-MOA-SG5-SG6-SG7-SG10			
SG10 - 9999 SEQ-DTM-BUS-FII-SG11-SG12-SG13-SG14-SG15-SG16-SG17-SG20			
SG15 - 3 INP-FTX-DTM			
UN/EDIFACT Directory 96.A C		D6 O	
A group of segments containing instructions relating to parties identified in the NAD and FII segments in Segment Group 2 and/or Segment Group 3. It specifies action taken or to be taken by the identified parties, and the date (and optionally time) by which such action was taken or needs to be taken.		National scenarios may apply.	
INP - 1 Parties to instruction			
UN/EDIFACT Directory 96.A M		D6 M	
A segment identifying the party to enact the instruction, the parties contacted or to be contacted at or by the associated financial institution on matters concerning the execution of the payment. It specifies where appropriate the instruction in coded form.			
Segment number : 48			
UN/EDIFACT Directory 96.A		D6 Description	
		CRG Description	
C849 Parties to instruction	C	O	
3301 Party enacting instruction identification	M an..17	M	
3285 Recipient of the instruction identification	C an..17	O	
C522 Instruction	C	O	
4403 Instruction qualifier	M an..3	M	2 = Party instructions
4401 Instruction, coded	C an..3	O	
1131 Code list qualifier	C an..3	O	
3055 Code list responsible agency, coded	C an..3	O	
4400 Instruction	C an..35	O	
C850 Status of instruction	C	O	
4405 Status, coded	M an..3	M	
3036 Party name	C an..35	O	
1229 Action request/notification, coded	C an..3	O	
<u>Example:</u> INP+3:4+2:AD'			

SG4 - 9999 LIN-DTM-BUS-MOA-SG5-SG6-SG7-SG10			
SG10 - 9999 SEQ-DTM-BUS-FII-SG11-SG12-SG13-SG14-SG15-SG16-SG17-SG20			
SG15 - 3 INP-FTX-DTM			
FTX - 1 Free text			
UN/EDIFACT Directory 96.A C		D6 O	
A segment providing free text instructions related to the associated INP segment.		CRG N	
Segment number : 49			
UN/EDIFACT Directory 96.A		D6 Description	
		CRG Description	
4451 Text subject qualifier	M an..3	M *R	AAG = Party instructions
4453 Text function, coded	C an..3	N	
C107 Text reference	C	O	
4441 Free text, coded	M an..3	M	Only nationally agreed coded free text may be used.
1131 Code list qualifier	C an..3	O	
3055 Code list responsible agency, coded	C an..3	O	
C108 Text literal	C	R	
4440 Free text	M an..70	M	
4440 Free text	C an..70	O	
4440 Free text	C an..70	O	
4440 Free text	C an..70	O	
4440 Free text	C an..70	O	
3453 Language, coded	C an..3	O	
<u>Example:</u>			
FTX+AAG+++BEWARE EMBARGO PAYMENTS+EN'			

SG4 - 9999 LIN-DTM-BUS-MOA-SG5-SG6-SG7-SG10					
SG10 - 9999 SEQ-DTM-BUS-FII-SG11-SG12-SG13-SG14-SG15-SG16-SG17-SG20					
SG15 - 3 INP-FTX-DTM					
DTM - 1 Date/time/period					
UN/EDIFACT Directory 96.A C			D6 O		CRG N
A segment specifying the earliest and latest dates and/or times by which the specified instructions must be carried out.					
Segment number : 50					
UN/EDIFACT Directory 96.A			D6 Description		CRG Description
C507 Date/time/period	M	M			
2005 Date/time/period qualifier	M an..3	M	*	174 = Advise after date/time	
			*	175 = Advise before date/time	
			*	176 = Advise completed date/time	
			*	177 = Advise on date/time	
2380 Date/time/period	C an..35	R			
2379 Date/time/period format qualifier	C an..3	R	*	102 = CCYYMMDD	
			*	203 = CCYYMMDDHHMM	
<u>Example:</u>					
DTM+174:200001031130:203'					

SG4 - 9999 LIN-DTM-BUS-MOA-SG5-SG6-SG7-SG10			
SG10 - 9999 SEQ-DTM-BUS-FII-SG11-SG12-SG13-SG14-SG15-SG16-SG17-SG20			
SG16 - 10 GIS-MOA-LOC-NAD-RCS-FTX			
UN/EDIFACT Directory 96.A C		D6 O	
A group of segments providing information for subsequent use by regulatory authorities requiring statistical and other types of data. It also identifies the regulatory authority for which the information is intended followed by the information itself.		The specifications of this segment group are to be determined on unilateral regulatory reporting requirements.	
GIS - 1 General indicator			
UN/EDIFACT Directory 96.A M		D6 M	
A segment identifying what processing should be completed for regulatory authorities.			
Segment number : 51			
UN/EDIFACT Directory 96.A		D6 Description	
C529 Processing indicator	M	M	
7365 Processing indicator, coded	M an..3	M	
1131 Code list qualifier	C an..3	O	
3055 Code list responsible agency, coded	C an..3	O	
7187 Process type identification	C an..17	O	
		CRG Description	

SG4 - 9999 LIN-DTM-BUS-MOA-SG5-SG6-SG7-SG10			
SG10 - 9999 SEQ-DTM-BUS-FII-SG11-SG12-SG13-SG14-SG15-SG16-SG17-SG20			
SG16 - 10 GIS-MOA-LOC-NAD-RCS-FTX			
MOA - 1 Monetary amount			
UN/EDIFACT Directory 96.A C		D6 O	
A segment giving the amount and the currency of each transaction to be reported.		The specifications of this segment group are to be determined on unilateral regulatory reporting requirements.	
Segment number : 52			
UN/EDIFACT Directory 96.A		D6 Description	
CRG Description			
C516 Monetary amount	M	M	
5025 Monetary amount type qualifier	M an..3	M	
5004 Monetary amount	C n..18	O	
6345 Currency, coded	C an..3	O	
6343 Currency qualifier	C an..3	O	
4405 Status, coded	C an..3	O	

SG4 - 9999 LIN-DTM-BUS-MOA-SG5-SG6-SG7-SG10			
SG10 - 9999 SEQ-DTM-BUS-FII-SG11-SG12-SG13-SG14-SG15-SG16-SG17-SG20			
SG16 - 10 GIS-MOA-LOC-NAD-RCS-FTX			
LOC - 2 Place/location identification			
UN/EDIFACT Directory 96.A C		D6 O	
A segment giving the different origins/destinations (places) of goods/ investment/services.		The specifications of this segment group are to be determined on unilateral regulatory reporting requirements.	
Segment number : 53			
UN/EDIFACT Directory 96.A		D6 Description	
		CRG Description	
3227 Place/location qualifier	M an..3	M	
C517 Location identification	C	O	
3225 Place/location identification	C an..25	O	
1131 Code list qualifier	C an..3	O	
3055 Code list responsible agency, coded	C an..3	O	
3224 Place/location	C an..70	O	
C519 Related location one identification	C	O	
3223 Related place/location one identification	C an..25	O	
1131 Code list qualifier	C an..3	O	
3055 Code list responsible agency, coded	C an..3	O	
3222 Related place/location one	C an..70	O	
C553 Related location two identification	C	O	
3233 Related place/location two identification	C an..25	O	
1131 Code list qualifier	C an..3	O	
3055 Code list responsible agency, coded	C an..3	O	
3232 Related place/location two	C an..70	O	
5479 Relation, coded	C an..3	O	

SG4 - 9999 LIN-DTM-BUS-MOA-SG5-SG6-SG7-SG10			
SG10 - 9999 SEQ-DTM-BUS-FII-SG11-SG12-SG13-SG14-SG15-SG16-SG17-SG20			
SG16 - 10 GIS-MOA-LOC-NAD-RCS-FTX			
NAD - 1 Name and address			
UN/EDIFACT Directory 96.A C		D6 O	
A segment identifying the recipient of the associated informative text.		The specifications of this segment group are to be determined on unilateral regulatory reporting requirements.	
Segment number : 54			
UN/EDIFACT Directory 96.A		D6 Description	
		CRG Description	
3035 Party qualifier	M an..3	M	
C082 Party identification details	C	O	
3039 Party id. identification	M an..35	M	
1131 Code list qualifier	C an..3	O	
3055 Code list responsible agency, coded	C an..3	O	
C058 Name and address	C	O	
3124 Name and address line	M an..35	M	
3124 Name and address line	C an..35	O	
3124 Name and address line	C an..35	O	
3124 Name and address line	C an..35	O	
3124 Name and address line	C an..35	O	
C080 Party name	C	O	
3036 Party name	M an..35	M	
3036 Party name	C an..35	O	
3036 Party name	C an..35	O	
3036 Party name	C an..35	O	
3036 Party name	C an..35	O	
3045 Party name format, coded	C an..3	O	
C059 Street	C	O	
3042 Street and number/p.o. box	M an..35	M	
3042 Street and number/p.o. box	C an..35	O	
3042 Street and number/p.o. box	C an..35	O	
3042 Street and number/p.o. box	C an..35	O	
3164 City name	C an..35	O	
3229 Country sub-entity identification	C an..9	O	
3251 Postcode identification	C an..9	O	
3207 Country, coded	C an..3	O	ISO 3166 two alpha country code.

SG4 - 9999 LIN-DTM-BUS-MOA-SG5-SG6-SG7-SG10			
SG10 - 9999 SEQ-DTM-BUS-FII-SG11-SG12-SG13-SG14-SG15-SG16-SG17-SG20			
SG16 - 10 GIS-MOA-LOC-NAD-RCS-FTX			
RCS - 1 Requirements and conditions			
UN/EDIFACT Directory 96.A C		D6 O	
A segment giving the nature (e.g. goods, transport services) and direction of each transaction to be recorded in coded form.		The specifications of this segment group are to be determined on unilateral regulatory reporting requirements.	
Segment number : 55			
UN/EDIFACT Directory 96.A		D6 Description	
CRG Description			
7293	Sector/subject identification qualifier	M an..3	M
C550	Requirement/condition identification	C	O
7295	Requirement/condition identification	M an..17	M
1131	Code list qualifier	C an..3	O
3055	Code list responsible agency, coded	C an..3	O
7294	Requirement or condition	C an..35	O
1229	Action request/notification, coded	C an..3	O

SG4 - 9999 LIN-DTM-BUS-MOA-SG5-SG6-SG7-SG10			
SG10 - 9999 SEQ-DTM-BUS-FII-SG11-SG12-SG13-SG14-SG15-SG16-SG17-SG20			
SG16 - 10 GIS-MOA-LOC-NAD-RCS-FTX			
FTX - 10 Free text			
UN/EDIFACT Directory 96.A C		D6 O	
A segment giving information, in coded or clear form, to provide information relevant to regulatory authorities requirements.		The specifications of this segment group are to be determined on unilateral regulatory reporting requirements.	
Segment number : 56			
UN/EDIFACT Directory 96.A		D6 Description	
		CRG Description	
4451	Text subject qualifier	M an..3	M
4453	Text function, coded	C an..3	O
C107	Text reference	C	O
4441	Free text, coded	M an..3	M
1131	Code list qualifier	C an..3	O
3055	Code list responsible agency, coded	C an..3	O
C108	Text literal	C	O
4440	Free text	M an..70	M
4440	Free text	C an..70	O
4440	Free text	C an..70	O
4440	Free text	C an..70	O
4440	Free text	C an..70	O
3453	Language, coded	C an..3	O

SG4 - 9999 LIN-DTM-BUS-MOA-SG5-SG6-SG7-SG10						
SG10 - 9999 SEQ-DTM-BUS-FII-SG11-SG12-SG13-SG14-SG15-SG16-SG17-SG20						
SG17 - 5 FCA-MOA-SG18						
UN/EDIFACT Directory 96.A C			D6 D		CRG D	
A group of segments providing full details of all charges or allowances, and associated taxes, that apply to a particular transaction, together with information as to who bears the charges and to which account they have been directed. A total value of all charges plus allowances may be given for every account to which charges may be directed. Where charges are subject to taxation this may also be specified.			This segment group is only used according to Option 3 described in SG07. In this situation both SG07 and SG17 are used and the single amounts in SG17 have to be summed up into SG07 when charges/allowances are not included in the transaction.			
FCA - 1 Financial charges allocation						
UN/EDIFACT Directory 96.A M			D6 M		CRG M	
A segment specifying the method for allocation of charges and allowances and identifying an account to which such charges or allowances were directed where it is different from the principal account.						
Segment number : 57						
UN/EDIFACT Directory 96.A			D6 Description		CRG Description	
4471 Settlement, coded	M an..3	M	*	13 = All charges borne by payee (or beneficiary)		
			*	14 = Each pay own cost		
			*	15 = All charges borne by payor		
C878 Charge/allowance account	C	O		If no account is mentioned, charges will be booked according to bilateral agreement.	N	
3434 Institution branch number	M an..17	M		National identification of the financial institution in coded form.	N	
1131 Code list qualifier	C an..3	R	*	The allowed combinations of the codes of DE1131 and 3055 are stated in Section 1.5. of this MIG.	N	
3055 Code list responsible agency, coded	C an..3	R	*	The allowed combinations of the codes of DE1131 and 3055 are stated in Section 1.5. of this MIG.	N	
3194 Account holder number	C an..35	R			N	
6345 Currency, coded	C an..3	O		ISO 4217 three alpha currency code.	N	
<u>Example:</u>						
FCA+13+5080000:25:131:89534931:EUR'						

SG4 - 9999 LIN-DTM-BUS-MOA-SG5-SG6-SG7-SG10			
SG10 - 9999 SEQ-DTM-BUS-FII-SG11-SG12-SG13-SG14-SG15-SG16-SG17-SG20			
SG17 - 5 FCA-MOA-SG18			
MOA - 2 Monetary amount			
UN/EDIFACT Directory 96.A C		D6 D	
A segment identifying the basis amount from which charges are calculated, if different from the overall amount of the original order. It also gives the total value of charges and/or allowances, and associated taxes, that relate to an account for charges/allowances.		This segment is only used when the amount of charges or allowances affects the account holder.	
Segment number : 58			
UN/EDIFACT Directory 96.A		D6 Description	
C516 Monetary amount		M	M
5025 Monetary amount type qualifier	M an..3	M	* * * * *
			488 = Total charges, not included in the transaction amount. 489 = Total allowances, not included in the transaction amount. 259 = Total charges - included in the transaction amount. 260 = Total allowances - included in the transaction amount. 25 = Charge/allowance basis – specification of the basis amount is mandatory if the amount received or converted is not used as the basis for the charges/allowances calculation.
5004 Monetary amount	C n..18	R	
6345 Currency, coded	C an..3	R	ISO 4217 currency code.
6343 Currency qualifier	C an..3	N	
4405 Status, coded	C an..3	N	
<u>Example:</u> MOA+259:180:EUR'			

SG4 - 9999 LIN-DTM-BUS-MOA-SG5-SG6-SG7-SG10			
SG10 - 9999 SEQ-DTM-BUS-FII-SG11-SG12-SG13-SG14-SG15-SG16-SG17-SG20			
SG17 - 5 FCA-MOA-SG18			
SG18 - 20 ALC-PCD-MOA-CUX-DTM-SG19			
UN/EDIFACT Directory 96.A C	D6	O	CRG O
A group of segments providing a detailed breakdown of all charges (or allowances) and associated charges (or allowances).			
ALC - 1 Allowance or charge			
UN/EDIFACT Directory 96.A M	D6	M	CRG M
A segment providing full details of each charge or allowance for which the Payee is liable. Included are full details of the method of calculating the charge.			
Segment number : 59			
UN/EDIFACT Directory 96.A	D6 Description		CRG Description
5463 Allowance or charge qualifier	M an..3	M * *	A = Allowance C = Charge
C552 Allowance/charge information	C	O	Identification of allowance/charge information relating to the amount.
1230 Allowance or charge number	C an..35	O	
5189 Charge/allowance description, coded	C an..3	R	
4471 Settlement, coded	C an..3	N	
1227 Calculation sequence indicator, coded	C an..3	N	
C214 Special services identification	C	O	
7161 Special services, coded	C an..3	O	
1131 Code list qualifier	C an..3	O	
3055 Code list responsible agency, coded	C an..3	O	
7160 Special service	C an..35	O	
7160 Special service	C an..35	O	
<u>Example:</u> ALC+C+:55'			

SG4 - 9999 LIN-DTM-BUS-MOA-SG5-SG6-SG7-SG10					
SG10 - 9999 SEQ-DTM-BUS-FII-SG11-SG12-SG13-SG14-SG15-SG16-SG17-SG20					
SG17 - 5 FCA-MOA-SG18					
SG18 - 20 ALC-PCD-MOA-CUX-DTM-SG19					
PCD - 1 Percentage details					
UN/EDIFACT Directory 96.A C			D6 O		CRG O
A segment specifying the percentage used for calculating the charges (or allowances).			This segment is used if the calculation of the amount is based on a percentage.		
Segment number : 60					
UN/EDIFACT Directory 96.A			D6 Description		CRG Description
C501 Percentage details	M	M		3 = Allowance or charges Specification of the percentage set; a value of zero is not permitted.	
5245 Percentage qualifier	M an..3	M			
5482 Percentage	C n..10	R			
5249 Percentage basis, coded	C an..3	N			
1131 Code list qualifier	C an..3	N			
3055 Code list responsible agency, coded	C an..3	N			
<u>Example:</u> PCD+3:0,4'					

SG4 - 9999 LIN-DTM-BUS-MOA-SG5-SG6-SG7-SG10			
SG10 - 9999 SEQ-DTM-BUS-FII-SG11-SG12-SG13-SG14-SG15-SG16-SG17-SG20			
SG17 - 5 FCA-MOA-SG18			
SG18 - 20 ALC-PCD-MOA-CUX-DTM-SG19			
MOA - 2 Monetary amount			
UN/EDIFACT Directory 96.A C		D6 R	
A segment identifying the amount of charges (or allowances) and/or specifying the basis amount from which charges (or allowances) may be calculated if different from the MOA segment.		A segment identifying the amount of charges (or allowances) and/or specifying the basis amount from which charges (or allowances) may be calculated if different from the MOA segment in SG17.	
Segment number : 61			
UN/EDIFACT Directory 96.A		D6 Description	
C516 Monetary amount			
5025 Monetary amount type qualifier	M M an..3	M M	The meaning of the codes must be identical to those in the ALC and PCD segments. * 23 = Charge amount * 25 = Charge/allowance basis - the basis must be different to that contained in MOA, in SG 17 * 204 = Allowance amount This data element is mandatory if an amount is calculated or if a basis is quoted. This data element is not used if code 18 (free of charge) is used in DE 4405. ISO 4217 currency code. This DE is only used when DE 5004 is used. This DE must not be used if code 25 is used in DE 5025. * 6 = Minimum * 7 = Fixed * 8 = Maximum * 9 = Information – this code is not used if code 259 or 260 are used in DE 5025, MOA segment, SG07. * 18 = Free of charge - there is no amount in data element 5004. * 19 = Rounded - the absence of this data element means that the amount is exactly as calculated .
5004 Monetary amount	C n..18	D	
6345 Currency, coded	C an..3	D	
6343 Currency qualifier	C an..3	N	
4405 Status, coded	C an..3	D	
<u>Example:</u> MOA+23:150:EUR::7'			

SG4 - 9999 LIN-DTM-BUS-MOA-SG5-SG6-SG7-SG10			
SG10 - 9999 SEQ-DTM-BUS-FII-SG11-SG12-SG13-SG14-SG15-SG16-SG17-SG20			
SG17 - 5 FCA-MOA-SG18			
SG18 - 20 ALC-PCD-MOA-CUX-DTM-SG19			
CUX - 1 Currencies			
UN/EDIFACT Directory 96.A C	D6 N	CRG N	
A segment specifying rates related to the charges and allowances.			
Segment number : 62			
UN/EDIFACT Directory 96.A	D6 Description		CRG Description
C504 Currency details	C		
6347 Currency details qualifier	M an..3		
6345 Currency, coded	C an..3		
6343 Currency qualifier	C an..3		
6348 Currency rate base	C n..4		
C504 Currency details	C		
6347 Currency details qualifier	M an..3		
6345 Currency, coded	C an..3		
6343 Currency qualifier	C an..3		
6348 Currency rate base	C n..4		
5402 Rate of exchange	C n..12		
6341 Currency market exchange, coded	C an..3		

SG4 - 9999 LIN-DTM-BUS-MOA-SG5-SG6-SG7-SG10			
SG10 - 9999 SEQ-DTM-BUS-FII-SG11-SG12-SG13-SG14-SG15-SG16-SG17-SG20			
SG17 - 5 FCA-MOA-SG18			
SG18 - 20 ALC-PCD-MOA-CUX-DTM-SG19			
DTM - 2 Date/time/period			
UN/EDIFACT Directory 96.A C		D6 N	
UN/EDIFACT Directory 96.A C		CRG N	
A segment identifying the effective date and/or time the rate of exchange was fixed.			
Segment number : 63			
UN/EDIFACT Directory 96.A		D6 Description	
UN/EDIFACT Directory 96.A		CRG Description	
C507	Date/time/period	M	
2005	Date/time/period qualifier	M an..3	
2380	Date/time/period	C an..35	
2379	Date/time/period format qualifier	C an..3	

SG4 - 9999 LIN-DTM-BUS-MOA-SG5-SG6-SG7-SG10						
SG10 - 9999 SEQ-DTM-BUS-FII-SG11-SG12-SG13-SG14-SG15-SG16-SG17-SG20						
SG17 - 5 FCA-MOA-SG18						
SG18 - 20 ALC-PCD-MOA-CUX-DTM-SG19						
SG19 - 5 TAX-MOA-CUX-DTM						
MOA - 2 Monetary amount						
UN/EDIFACT Directory 96.A C			D6 O		CRG O	
A segment specifying the total amount of the tax and the basis for calculation.						
Segment number : 65						
UN/EDIFACT Directory 96.A			D6 Description		CRG Description	
C516 Monetary amount	M	M				
5025 Monetary amount type qualifier	M an..3	M		56 = Duty/tax/fee basis amount 124 = Tax amount 204 = Allowance amount		
5004 Monetary amount	C n..18	R				
6345 Currency, coded	C an..3	R		ISO 4217 three alpha currency code.		
6343 Currency qualifier	C an..3	N				
4405 Status, coded	C an..3	D		The absence of this data element means that the amount in DE 5004 is an exact calculated amount. 6 = Minimum 7 = Fixed 8 = Maximum 9 = Information 19 = Rounded		
<u>Example:</u> MOA+124:30:EUR::8'						

SG4 - 9999 LIN-DTM-BUS-MOA-SG5-SG6-SG7-SG10			
SG10 - 9999 SEQ-DTM-BUS-FII-SG11-SG12-SG13-SG14-SG15-SG16-SG17-SG20			
SG17 - 5 FCA-MOA-SG18			
SG18 - 20 ALC-PCD-MOA-CUX-DTM-SG19			
SG19 - 5 TAX-MOA-CUX-DTM			
CUX - 1 Currencies			
UN/EDIFACT Directory 96.A C		D6 O	
A segment specifying exchange rates.		<p>The exchange rate is specified if a converted amount is in the preceding MOA segment.</p> <p><u>Calculation formula:</u> <i>Case 1) Base rate is indicated next to reference currency:</i> Converted amount = Original amount * (exchange rate / rate base) <i>Case 2) Base rate is indicated next to target currency:</i> Converted amount = Original amount / (exchange rate / rate base)</p>	
Segment number : 66			
UN/EDIFACT Directory 96.A		D6 Description	
<p>C504 Currency details</p> <p>6347 Currency details qualifier C 6345 Currency, coded M an..3 6343 Currency qualifier C an..3 6348 Currency rate base C n..4</p>		<p>R</p> <p>*R 2 = Reference currency. This is the source currency. R ISO 4217 three alpha currency code. N D This DE is used only when an exchange rate is quoted in DE 5402. It is mutually exclusive with DE 6348 in the following C504. * 1 = the rate base is 1 * 100 = the rate base is 100 * 1000 = the rate base is 1000</p>	
<p>C504 Currency details</p> <p>6347 Currency details qualifier C 6345 Currency, coded M an..3 6343 Currency qualifier C an..3 6348 Currency rate base C n..4</p>		<p>D</p> <p>*R 3 = Target currency R ISO 4217 three alpha currency code. N D This DE is used only when an exchange rate is quoted in DE 5402. It is mutually exclusive with DE 6348 in the previous C504. * 1 = the rate base is 1 * 100 = the rate base is 100 * 1000 = the rate base is 1000</p>	
		CRG Description	

5402	Rate of exchange	C	n..12	O					
6341	Currency market exchange, coded	C	an..3	N					
<u>Example:</u> CUX+2:USD+3:EUR::1+1,05'									

SG4 - 9999 LIN-DTM-BUS-MOA-SG5-SG6-SG7-SG10						
SG10 - 9999 SEQ-DTM-BUS-FII-SG11-SG12-SG13-SG14-SG15-SG16-SG17-SG20						
SG17 - 5 FCA-MOA-SG18						
SG18 - 20 ALC-PCD-MOA-CUX-DTM-SG19						
SG19 - 5 TAX-MOA-CUX-DTM						
DTM - 1 Date/time/period						
UN/EDIFACT Directory 96.A C			D6 O		CRG O	
A segment identifying the effective date and/or time the rate of exchange was fixed.						
Segment number : 67						
UN/EDIFACT Directory 96.A			D6 Description		CRG Description	
C507	Date/time/period	M	M			
2005	Date/time/period qualifier	M an..3	M		134 = Rate of exchange date/time	
2380	Date/time/period	C an..35	R			
2379	Date/time/period format qualifier	C an..3	R		102 = CCYYMMDD Code 102 is recommended. 203 = CCYYMMDDHHMM	
<u>Example:</u>						
DTM+134:19970630:102'						

SG4 - 9999 LIN-DTM-BUS-MOA-SG5-SG6-SG7-SG10			
SG10 - 9999 SEQ-DTM-BUS-FII-SG11-SG12-SG13-SG14-SG15-SG16-SG17-SG20			
SG20 - 1 PRC-FTX-SG21-SG27			
UN/EDIFACT Directory 96.A C		D6 O	
A group of segments containing the details of payment. The content of these segments is passed through the banking chain from the Ordering Customer to the Beneficiary.			
PRC - 1 Process identification			
UN/EDIFACT Directory 96.A M		D6 M	
A segment identifying the kind of process at the beneficiary's side.		This segment is also used as a trigger segment for SG 21.	
Segment number : 68			
UN/EDIFACT Directory 96.A		D6 Description	
C242 Process type and description 7187 Process type identification		M	M
	M an..17	M	* * * *
			8 = Processing of structured information - only the DOC segment group must follow 9 = Processing of identical information in structured and unstructured form - the DOC segment group and FTX segment must follow 10 = Processing of different information in structured and unstructured form - the DOC segment group and FTX segment must follow 11 = Processing of unstructured information - only the FTX segment must follow
1131 Code list qualifier	C an..3	N	
3055 Code list responsible agency, coded	C an..3	N	
7186 Process type	C an..35	N	
7186 Process type	C an..35	N	
<u>Example:</u>			
PRC+8'			

SG4 - 9999 LIN-DTM-BUS-MOA-SG5-SG6-SG7-SG10					
SG10 - 9999 SEQ-DTM-BUS-FII-SG11-SG12-SG13-SG14-SG15-SG16-SG17-SG20					
SG20 - 1 PRC-FTX-SG21-SG27					
FTX - 5 Free text					
UN/EDIFACT Directory 96.A C			D6 D		CRG D
A segment providing free text information from the ordering customer to the beneficiary.					
Segment number : 69					
UN/EDIFACT Directory 96.A			D6 Description		CRG Description
4451	Text subject qualifier	M an..3	M	*R	PMD = Payment detail/remittance information Only nationally agreed coded free text may be used.
4453	Text function, coded	C an..3	N		
C107	Text reference	C	O		
4441	Free text, coded	M an..3	M		
1131	Code list qualifier	C an..3	O		
3055	Code list responsible agency, coded	C an..3	O		
C108	Text literal	C	O		
4440	Free text	M an..70	M		
4440	Free text	C an..70	O		
4440	Free text	C an..70	O		
4440	Free text	C an..70	O		
4440	Free text	C an..70	O		
3453	Language, coded	C an..3	O		
<u>Example:</u>					
FTX+PMD+++SALARY DUE'					

SG4 - 9999 LIN-DTM-BUS-MOA-SG5-SG6-SG7-SG10		
SG10 - 9999 SEQ-DTM-BUS-FII-SG11-SG12-SG13-SG14-SG15-SG16-SG17-SG20		
SG20 - 1 PRC-FTX-SG21-SG27		
SG21 - 9999 DOC-MOA-DTM-RFF-NAD-SG22-SG23-(FTX)SG24 * See branching diagram		
UN/EDIFACT Directory 96.A C	D6 D	CRG D
A group of segments providing details of all documents, e.g. invoices, statements, despatch advices, etc., to which the multiple credit advice refers. It includes information on the monetary amounts for each document and on any adjustments (with an indication of the reason for adjustments) and discounts. For information purposes an indication of the tax element can be provided.	Information in this segment group (SG 21 through 24) can originate from the ordering customer or the financial institution. In the first case, the information will be passed through unchanged. In the second case, national scenarios will apply. <i>The UN EDIFACT structure shows the FTX segment in brackets as part of SG21. However, this is inconsistent with all other financial messages. Therefore it has been decided to treat this FTX segment as part of SG23 as in all other financial messages.</i>	
DOC - 1 Document/message details		
UN/EDIFACT Directory 96.A M	D6 M	CRG M
A segment identifying the reference document against which payment is being made.	Information in this segment can originate from the ordering customer or the financial institution. In the first case, the information will be passed through unchanged. In the second case, national scenarios will apply.	
Segment number : 70		
UN/EDIFACT Directory 96.A	D6 Description	CRG Description
C002 Document/message name	M M	
1001 Document/message name, coded	C an..3 O	
1131 Code list qualifier	C an..3 O	
3055 Code list responsible agency, coded	C an..3 O	
1000 Document/message name	C an..35 O	
C503 Document/message details	C O	
1004 Document/message number	C an..35 O	
1373 Document/message status, coded	C an..3 O	
1366 Document/message source	C an..35 O	
3453 Language, coded	C an..3 O	
3153 Communication channel identifier, coded	C an..3 O	
1220 Number of copies of document required	C n..2 O	
1218 Number of originals of document required	C n..2 O	



SG4 - 9999 LIN-DTM-BUS-MOA-SG5-SG6-SG7-SG10			
SG10 - 9999 SEQ-DTM-BUS-FII-SG11-SG12-SG13-SG14-SG15-SG16-SG17-SG20			
SG20 - 1 PRC-FTX-SG21-SG27			
SG21 - 9999 DOC-MOA-DTM-RFF-NAD-SG22-SG23- (FTX-) SG24 * See branching diagram			
MOA - 5 Monetary amount			
UN/EDIFACT Directory 96.A C		D6 O	
A segment giving the monetary amounts of each reference document (e.g., original amount, discount amount etc.). The amount due and the amount remitted are mandatory.		Information in this segment can originate from the ordering customer or the financial institution. In the first case, the information will be passed through unchanged. In the second case, national scenarios will apply.	
Segment number : 71			
UN/EDIFACT Directory 96.A		D6 Description	
CRG Description			
C516 Monetary amount	M	M	
5025 Monetary amount type qualifier	M an..3	M	
5004 Monetary amount	C n..18	O	
6345 Currency, coded	C an..3	O	
6343 Currency qualifier	C an..3	O	
4405 Status, coded	C an..3	O	

SG4 - 9999 LIN-DTM-BUS-MOA-SG5-SG6-SG7-SG10			
SG10 - 9999 SEQ-DTM-BUS-FII-SG11-SG12-SG13-SG14-SG15-SG16-SG17-SG20			
SG20 - 1 PRC-FTX-SG21-SG27			
SG21 - 9999 DOC-MOA-DTM-RFF-NAD-SG22-SG23-(FTX)-SG24 * See branching diagram			
DTM - 5 Date/time/period			
UN/EDIFACT Directory 96.A C		D6 O	
A segment specifying the date of the referenced document and indicating any other relevant dates applicable.		Information in this segment can originate from the ordering customer or the financial institution. In the first case, the information will be passed through unchanged. In the second case, national scenarios will apply.	
Segment number : 72			
UN/EDIFACT Directory 96.A		D6 Description	
CRG Description			
C507 Date/time/period	M	M	
2005 Date/time/period qualifier	M an..3	M	
2380 Date/time/period	C an..35	O	
2379 Date/time/period format qualifier	C an..3	O	

SG4 - 9999 LIN-DTM-BUS-MOA-SG5-SG6-SG7-SG10			
SG10 - 9999 SEQ-DTM-BUS-FII-SG11-SG12-SG13-SG14-SG15-SG16-SG17-SG20			
SG20 - 1 PRC-FTX-SG21-SG27			
SG21 - 9999 DOC-MOA-DTM-RFF-NAD-SG22-SG23-(FTX)SG24 * See branching diagram			
RFF - 5 Reference			
UN/EDIFACT Directory 96.A C		D6 O	
A segment for the inclusion of any additional references related to the reference document.		Information in this segment can originate from the ordering customer or the financial institution. In the first case, the information will be passed through unchanged. In the second case, national scenarios will apply.	
Segment number : 73			
UN/EDIFACT Directory 96.A		D6 Description	
C506 Reference			
1153 Reference qualifier	M	M	
1154 Reference number	M an..3	M	
1156 Line number	C an..35	O	
4000 Reference version number	C an..6	O	
	C an..35	O	
		CRG Description	

SG4 - 9999 LIN-DTM-BUS-MOA-SG5-SG6-SG7-SG10			
SG10 - 9999 SEQ-DTM-BUS-FII-SG11-SG12-SG13-SG14-SG15-SG16-SG17-SG20			
SG20 - 1 PRC-FTX-SG21-SG27			
SG21 - 9999 DOC-MOA-DTM-RFF-NAD-SG22-SG23-(<i>FTX</i> -)SG24 * See branching diagram			
NAD - 2 Name and address			
UN/EDIFACT Directory 96.A C	D6 O	CRG O	
A segment identifying a party name and address, either by coded identification or in a clear form.	Information in this segment can originate from the ordering customer or the financial institution. In the first case, the information will be passed through unchanged. In the second case, national scenarios will apply.		
Segment number : 74			
UN/EDIFACT Directory 96.A	D6 Description		CRG Description
3035 Party qualifier	M an..3	M	
C082 Party identification details	C	O	
3039 Party id. identification	M an..35	M	
1131 Code list qualifier	C an..3	O	
3055 Code list responsible agency, coded	C an..3	O	
C058 Name and address	C	O	
3124 Name and address line	M an..35	M	
3124 Name and address line	C an..35	O	
3124 Name and address line	C an..35	O	
3124 Name and address line	C an..35	O	
3124 Name and address line	C an..35	O	
C080 Party name	C	O	
3036 Party name	M an..35	M	
3036 Party name	C an..35	O	
3036 Party name	C an..35	O	
3036 Party name	C an..35	O	
3036 Party name	C an..35	O	
3045 Party name format, coded	C an..3	O	
C059 Street	C	O	
3042 Street and number/p.o. box	M an..35	M	
3042 Street and number/p.o. box	C an..35	O	
3042 Street and number/p.o. box	C an..35	O	
3042 Street and number/p.o. box	C an..35	O	
3164 City name	C an..35	O	
3229 Country sub-entity identification	C an..9	O	
3251 Postcode identification	C an..9	O	
3207 Country, coded	C an..3	O	ISO 3166 two alpha country code.



SG4 - 9999 LIN-DTM-BUS-MOA-SG5-SG6-SG7-SG10			
SG10 - 9999 SEQ-DTM-BUS-FII-SG11-SG12-SG13-SG14-SG15-SG16-SG17-SG20			
SG20 - 1 PRC-FTX-SG21-SG27			
SG21 - 9999 DOC-MOA-DTM-RFF-NAD-SG22-SG23-(<i>FTX</i> -)SG24 * See branching diagram			
SG22 - 5 CUX-DTM			
UN/EDIFACT Directory 96.A C	D6	O	CRG O
A group of segments specifying the currencies and the related dates/ periods valid to the referenced document where different to the reference currency.			
CUX - 1 Currencies			
UN/EDIFACT Directory 96.A M	D6	M	CRG M
A segment identifying the currency and associated exchange rate of the referenced document where different to the remittance currency.			
Information in this segment can originate from the ordering customer or the financial institution. In the first case, the information will be passed through unchanged. In the second case, national scenarios will apply.			
Segment number : 75			
UN/EDIFACT Directory 96.A	D6 Description		CRG Description
C504 Currency details	C	O	
6347 Currency details qualifier	M an..3	M	
6345 Currency, coded	C an..3	O	
6343 Currency qualifier	C an..3	O	
6348 Currency rate base	C n..4	O	
C504 Currency details	C	O	
6347 Currency details qualifier	M an..3	M	
6345 Currency, coded	C an..3	O	
6343 Currency qualifier	C an..3	O	
6348 Currency rate base	C n..4	O	
5402 Rate of exchange	C n..12	O	
6341 Currency market exchange, coded	C an..3	O	

SG4 - 9999 LIN-DTM-BUS-MOA-SG5-SG6-SG7-SG10			
SG10 - 9999 SEQ-DTM-BUS-FII-SG11-SG12-SG13-SG14-SG15-SG16-SG17-SG20			
SG20 - 1 PRC-FTX-SG21-SG27			
SG21 - 9999 DOC-MOA-DTM-RFF-NAD-SG22-SG23- (FTX) SG24 * See branching diagram			
SG22 - 5 CUX-DTM			
DTM - 1 Date/time/period			
UN/EDIFACT Directory 96.A C		D6 O	
A segment specifying the date/time/period related to the rate of exchange.		Information in this segment can originate from the ordering customer or the financial institution. In the first case, the information will be passed through unchanged. In the second case, national scenarios will apply.	
Segment number : 76			
UN/EDIFACT Directory 96.A		D6 Description	
C507 Date/time/period		M	M
2005 Date/time/period qualifier	M an..3	M	
2380 Date/time/period	C an..35	O	
2379 Date/time/period format qualifier	C an..3	O	
		CRG Description	

SG4 - 9999 LIN-DTM-BUS-MOA-SG5-SG6-SG7-SG10			
SG10 - 9999 SEQ-DTM-BUS-FII-SG11-SG12-SG13-SG14-SG15-SG16-SG17-SG20			
SG20 - 1 PRC-FTX-SG21-SG27			
SG21 - 9999 DOC-MOA-DTM-RFF-NAD-SG22-SG23-(FTX)SG24 * See branching diagram			
SG23 - 100 AJT-MOA-RFF-FTX * See branching diagram			
MOA - 1 Monetary amount			
UN/EDIFACT Directory 96.A C		D6 O	
A segment giving the monetary amounts of the adjustments of each reference document (e.g. original amounts, discount amount, etc.). The currency data elements should not be used.		Information in this segment can originate from the ordering customer or the financial institution. In the first case, the information will be passed through unchanged. In the second case, national scenarios will apply.	
Segment number : 78			
UN/EDIFACT Directory 96.A		D6 Description	
C516 Monetary amount			
5025 Monetary amount type qualifier	M an..3	M	
5004 Monetary amount	C n..18	O	
6345 Currency, coded	C an..3	O	
6343 Currency qualifier	C an..3	O	
4405 Status, coded	C an..3	O	
		CRG Description	

SG4 - 9999 LIN-DTM-BUS-MOA-SG5-SG6-SG7-SG10			
SG10 - 9999 SEQ-DTM-BUS-FII-SG11-SG12-SG13-SG14-SG15-SG16-SG17-SG20			
SG20 - 1 PRC-FTX-SG21-SG27			
SG21 - 9999 DOC-MOA-DTM-RFF-NAD-SG22-SG23- (FTX) SG24 * See branching diagram			
SG23 - 100 AJT-MOA-RFF-FTX * See branching diagram			
RFF - 1 Reference			
UN/EDIFACT Directory 96.A C		D6 O	
A segment for the inclusion of any additional references related to the reference documents.		Information in this segment can originate from the ordering customer or the financial institution. In the first case, the information will be passed through unchanged. In the second case, national scenarios will apply.	
Segment number : 79			
UN/EDIFACT Directory 96.A		D6 Description	
C506 Reference			
1153 Reference qualifier	M	M	
1154 Reference number	M an..3	M	
1156 Line number	C an..35	O	
4000 Reference version number	C an..6	O	
	C an..35	O	
		CRG Description	

SG4 - 9999 LIN-DTM-BUS-MOA-SG5-SG6-SG7-SG10		
SG10 - 9999 SEQ-DTM-BUS-FII-SG11-SG12-SG13-SG14-SG15-SG16-SG17-SG20		
SG20 - 1 PRC-FTX-SG21-SG27		
SG21 - 9999 DOC-MOA-DTM-RFF-NAD-SG22-SG23- (FTX) SG24 * See branching diagram		
SG24 - 9999 DLI-MOA-PIA-DTM-SG25-SG26		
MOA - 5 Monetary amount		
UN/EDIFACT Directory 96.A C	D6 O	CRG O
A segment giving the monetary amounts for this line item.	Information in this segment can originate from the ordering customer or the financial institution. In the first case, the information will be passed through unchanged. In the second case, national scenarios will apply.	
Segment number : 82		
UN/EDIFACT Directory 96.A	D6 Description	CRG Description
C516 Monetary amount	M	M
5025 Monetary amount type qualifier	M an..3	M
5004 Monetary amount	C n..18	O
6345 Currency, coded	C an..3	O
6343 Currency qualifier	C an..3	O
4405 Status, coded	C an..3	O

SG4 - 9999 LIN-DTM-BUS-MOA-SG5-SG6-SG7-SG10						
SG10 - 9999 SEQ-DTM-BUS-FII-SG11-SG12-SG13-SG14-SG15-SG16-SG17-SG20						
SG20 - 1 PRC-FTX-SG21-SG27						
SG21 - 9999 DOC-MOA-DTM-RFF-NAD-SG22-SG23-(FTX)SG24 * See branching diagram						
SG24 - 9999 DLI-MOA-PIA-DTM-SG25-SG26						
PIA - 5 Additional product id						
UN/EDIFACT Directory 96.A C			D6 O		CRG O	
A segment specifying item identification codes where required.			Information in this segment can originate from the ordering customer or the financial institution. In the first case, the information will be passed through unchanged. In the second case, national scenarios will apply.			
Segment number : 83						
UN/EDIFACT Directory 96.A			D6 Description		CRG Description	
4347 Product id. function qualifier	M an..3	M				
C212 Item number identification	M	M				
7140 Item number	C an..35	O				
7143 Item number type, coded	C an..3	O				
1131 Code list qualifier	C an..3	O				
3055 Code list responsible agency, coded	C an..3	O				
C212 Item number identification	C	O				
7140 Item number	C an..35	O				
7143 Item number type, coded	C an..3	O				
1131 Code list qualifier	C an..3	O				
3055 Code list responsible agency, coded	C an..3	O				
C212 Item number identification	C	O				
7140 Item number	C an..35	O				
7143 Item number type, coded	C an..3	O				
1131 Code list qualifier	C an..3	O				
3055 Code list responsible agency, coded	C an..3	O				
C212 Item number identification	C	O				
7140 Item number	C an..35	O				
7143 Item number type, coded	C an..3	O				
1131 Code list qualifier	C an..3	O				
3055 Code list responsible agency, coded	C an..3	O				

SG4 - 9999 LIN-DTM-BUS-MOA-SG5-SG6-SG7-SG10			
SG10 - 9999 SEQ-DTM-BUS-FII-SG11-SG12-SG13-SG14-SG15-SG16-SG17-SG20			
SG20 - 1 PRC-FTX-SG21-SG27			
SG21 - 9999 DOC-MOA-DTM-RFF-NAD-SG22-SG23-(<i>FTX</i> -)SG24 * See branching diagram			
SG24 - 9999 DLI-MOA-PIA-DTM-SG25-SG26			
DTM - 5 Date/time/period			
UN/EDIFACT Directory 96.A C		D6 O	
A segment specifying the date/time/period related to the line item.		Information in this segment can originate from the ordering customer or the financial institution. In the first case, the information will be passed through unchanged. In the second case, national scenarios will apply.	
Segment number : 84			
UN/EDIFACT Directory 96.A		D6 Description	
UN/EDIFACT Directory 96.A		CRG Description	
C507	Date/time/period	M	M
2005	Date/time/period qualifier	M an..3	M
2380	Date/time/period	C an..35	O
2379	Date/time/period format qualifier	C an..3	O

SG4 - 9999 LIN-DTM-BUS-MOA-SG5-SG6-SG7-SG10		
SG10 - 9999 SEQ-DTM-BUS-FII-SG11-SG12-SG13-SG14-SG15-SG16-SG17-SG20		
SG20 - 1 PRC-FTX-SG21-SG27		
SG21 - 9999 DOC-MOA-DTM-RFF-NAD-SG22-SG23-(<i>FTX</i> -)SG24 * See branching diagram		
SG24 - 9999 DLI-MOA-PIA-DTM-SG25-SG26		
SG25 - 5 CUX-DTM		
UN/EDIFACT DIRECTORY 96.A C	D6 O	CRG O
A group of segments specifying the currency and the related dates/ periods of the line item where different from the remittance and document currency.		
CUX - 1 Currencies		
UN/EDIFACT DIRECTORY 96.A M	D6 M	CRG M
A segment identifying the currency and associated exchange rate of the line item where different to the source and target currency.		
Information in this segment can originate from the ordering customer or the financial institution. In the first case, the information will be passed through unchanged. In the second case, national scenarios will apply.		
Segment number : 85		
UN/EDIFACT Directory 96.A	D6 Description	CRG Description
C504 Currency details	C O	
6347 Currency details qualifier	M an..3 M	
6345 Currency, coded	C an..3 O	
6343 Currency qualifier	C an..3 O	
6348 Currency rate base	C n..4 O	
C504 Currency details	C O	
6347 Currency details qualifier	M an..3 M	
6345 Currency, coded	C an..3 O	
6343 Currency qualifier	C an..3 O	
6348 Currency rate base	C n..4 O	
5402 Rate of exchange	C n..12 O	
6341 Currency market exchange, coded	C an..3 O	

SG4 - 9999 LIN-DTM-BUS-MOA-SG5-SG6-SG7-SG10			
SG10 - 9999 SEQ-DTM-BUS-FII-SG11-SG12-SG13-SG14-SG15-SG16-SG17-SG20			
SG20 - 1 PRC-FTX-SG21-SG27			
SG21 - 9999 DOC-MOA-DTM-RFF-NAD-SG22-SG23- (FTX-) SG24 * See branching diagram			
SG24 - 9999 DLI-MOA-PIA-DTM-SG25-SG26			
SG25 - 5 CUX-DTM			
DTM - 1 Date/time/period			
UN/EDIFACT Directory 96.A C		D6 O	
A segment specifying the effective date and/or time the rate of exchange was fixed.		Information in this segment can originate from the ordering customer or the financial institution. In the first case, the information will be passed through unchanged. In the second case, national scenarios will apply.	
Segment number : 86			
UN/EDIFACT Directory 96.A		D6 Description	
CRG Description			
C507	Date/time/period	M	M
2005	Date/time/period qualifier	M an..3	M
2380	Date/time/period	C an..35	O
2379	Date/time/period format qualifier	C an..3	O

SG4 - 9999 LIN-DTM-BUS-MOA-SG5-SG6-SG7-SG10			
SG10 - 9999 SEQ-DTM-BUS-FII-SG11-SG12-SG13-SG14-SG15-SG16-SG17-SG20			
SG20 - 1 PRC-FTX-SG21-SG27			
SG21 - 9999 DOC-MOA-DTM-RFF-NAD-SG22-SG23-(FTX)-SG24 * See branching diagram			
SG24 - 9999 DLI-MOA-PIA-DTM-SG25-SG26			
SG26 - 10 AJT-MOA-RFF-FTX			
UN/EDIFACT Directory 96.A C	D6 O		CRG O
A group of segments indicating adjustment amounts and their referenced documents for this line item.			
AJT - 1 Adjustment details			
UN/EDIFACT Directory 96.A M	D6 M		CRG M
A segment indicating any adjustments to the amounts originally specified for this line item and the reason for the adjustment.		Information in this segment can originate from the ordering customer or the financial institution. In the first case, the information will be passed through unchanged. In the second case, national scenarios will apply.	
Segment number : 87			
UN/EDIFACT Directory 96.A	D6 Description		CRG Description
4465 Adjustment reason, coded	M an..3	M	
1082 Line item number	C n..6	O	

SG4 - 9999 LIN-DTM-BUS-MOA-SG5-SG6-SG7-SG10			
SG10 - 9999 SEQ-DTM-BUS-FII-SG11-SG12-SG13-SG14-SG15-SG16-SG17-SG20			
SG20 - 1 PRC-FTX-SG21-SG27			
SG21 - 9999 DOC-MOA-DTM-RFF-NAD-SG22-SG23-(FTX)SG24 * See branching diagram			
SG24 - 9999 DLI-MOA-PIA-DTM-SG25-SG26			
SG26 - 10 AJT-MOA-RFF-FTX			
MOA - 1 Monetary amount			
UN/EDIFACT Directory 96.A C		D6 O	
A segment giving the monetary amounts of the adjustments for this line item.		Information in this segment can originate from the ordering customer or the financial institution. In the first case, the information will be passed through unchanged. In the second case, national scenarios will apply.	
Segment number : 88			
UN/EDIFACT Directory 96.A		D6 Description	
CRG Description			
C516 Monetary amount	M		
5025 Monetary amount type qualifier	M an..3	M	
5004 Monetary amount	C n..18	O	
6345 Currency, coded	C an..3	O	
6343 Currency qualifier	C an..3	O	
4405 Status, coded	C an..3	O	

SG4 - 9999 LIN-DTM-BUS-MOA-SG5-SG6-SG7-SG10			
SG10 - 9999 SEQ-DTM-BUS-FII-SG11-SG12-SG13-SG14-SG15-SG16-SG17-SG20			
SG20 - 1 PRC-FTX-SG21-SG27			
SG21 - 9999 DOC-MOA-DTM-RFF-NAD-SG22-SG23- (FTX) SG24 * See branching diagram			
SG24 - 9999 DLI-MOA-PIA-DTM-SG25-SG26			
SG26 - 10 AJT-MOA-RFF-FTX			
RFF - 1 Reference			
UN/EDIFACT Directory 96.A C		D6 O	
A segment for the inclusion of any additional references related to the line item.		Information in this segment can originate from the ordering customer or the financial institution. In the first case, the information will be passed through unchanged. In the second case, national scenarios will apply.	
Segment number : 89			
UN/EDIFACT Directory 96.A		D6 Description	
C506 Reference		CRG Description	
1153 Reference qualifier	M	M	
1154 Reference number	M an..3	M	
1156 Line number	C an..35	O	
4000 Reference version number	C an..6	O	
	C an..35	O	

SG4 - 9999 LIN-DTM-BUS-MOA-SG5-SG6-SG7-SG10			
SG10 - 9999 SEQ-DTM-BUS-FII-SG11-SG12-SG13-SG14-SG15-SG16-SG17-SG20			
SG20 - 1 PRC-FTX-SG21-SG27			
SG21 - 9999 DOC-MOA-DTM-RFF-NAD-SG22-SG23-(FTX)-SG24 * See branching diagram			
SG24 - 9999 DLI-MOA-PIA-DTM-SG25-SG26			
SG26 - 10 AJT-MOA-RFF-FTX			
FTX - 5 Free text			
UN/EDIFACT Directory 96.A C		D6 O	
A segment providing free text information related to the payment details.		Information in this segment can originate from the ordering customer or the financial institution. In the first case, the information will be passed through unchanged. In the second case, national scenarios will apply.	
Segment number : 90			
UN/EDIFACT Directory 96.A		D6 Description	
UN/EDIFACT Directory 96.A		CRG Description	
4451	Text subject qualifier	M an..3	M
4453	Text function, coded	C an..3	O
C107	Text reference	C	O
4441	Free text, coded	M an..3	M
1131	Code list qualifier	C an..3	O
3055	Code list responsible agency, coded	C an..3	O
C108	Text literal	C	O
4440	Free text	M an..70	M
4440	Free text	C an..70	O
4440	Free text	C an..70	O
4440	Free text	C an..70	O
4440	Free text	C an..70	O
3453	Language, coded	C an..3	O

SG4 - 9999 LIN-DTM-BUS-MOA-SG5-SG6-SG7-SG10			
SG10 - 9999 SEQ-DTM-BUS-FII-SG11-SG12-SG13-SG14-SG15-SG16-SG17-SG20			
SG20 - 1 PRC-FTX-SG21-SG27			
SG27 - 1 GIS-MOA			
UN/EDIFACT Directory 96.A C		D6 O	
A group of segments indicating the end of the details of payment and specifying hash total amounts for control purposes.		Information in this segment can originate from the ordering customer or the financial institution. In the first case, the information will be passed through unchanged. In the second case, national scenarios will apply.	
GIS - 1 General indicator			
UN/EDIFACT Directory 96.A M		D6 M	
A segment identifying the end of the details of payment.			
Segment number : 91			
UN/EDIFACT Directory 96.A		D6 Description	
C529 Processing indicator			
7365 Processing indicator, coded	M		
1131 Code list qualifier	M an..3	M	37 = Complete information
3055 Code list responsible agency, coded	C an..3	N	
7187 Process type identification	C an..17	N	
<u>Example:</u>			
GIS+37'			

SG4 - 9999 LIN-DTM-BUS-MOA-SG5-SG6-SG7-SG10						
SG10 - 9999 SEQ-DTM-BUS-FII-SG11-SG12-SG13-SG14-SG15-SG16-SG17-SG20						
SG20 - 1 PRC-FTX-SG21-SG27						
SG27 - 1 GIS-MOA						
MOA - 5 Monetary amount						
UN/EDIFACT Directory 96.A C			D6 O		CRG N	
A segment indicating total amounts for control purposes.						
Segment number : 92						
UN/EDIFACT Directory 96.A			D6 Description		CRG Description	
C516 Monetary amount	M	M				
5025 Monetary amount type qualifier	M an..3	M				
5004 Monetary amount	C n..18	R				
6345 Currency, coded	C an..3	N				
6343 Currency qualifier	C an..3	N				
4405 Status, coded	C an..3	N				
<u>Example:</u>						
MOA+128:37500'						

CNT - 5 Control total						
UN/EDIFACT Directory 96.A C			D6 R		CRG R	
A segment identifying the kind of control checks and the totals according to the coded form.						
Segment number : 93						
UN/EDIFACT Directory 96.A			D6 Description		CRG Description	
C270 Control	M	M	M	* * 2 = Number of line items in message (LIN segments) 39 = Total number of individual transactions (= total number of occurrences of SEQ segments). The usage of code 2 is recommended.		
6069 Control qualifier	M an..3	M	M			
6066 Control value	M n..18	M	M			
6411 Measure unit qualifier	C an..3	N	N			
<u>Example:</u>						
CNT+2:1'						

SG28 - 5 AUT-DTM				
UN/EDIFACT Directory 96.A C		D6 O		CRG N
A group of segments specifying the details of any authentication (validation) procedures applied to the CREMUL message.		The use of this segment group, including algorithms and calculation procedures, is dependent on bilaterally agreed conditions between the sender and the receiver.		
AUT - 1 Authentication result				
UN/EDIFACT Directory 96.A M		D6 M		CRG N
A segment specifying details of any authentication (validation) procedures applied to the CREMUL message.				
Segment number : 94				
UN/EDIFACT Directory 96.A		D6 Description		CRG Description
9280 Validation result	M an..35	M		
9282 Validation key identification	C an..35	O		
<u>Example:</u> AUT+283926'				

SG28 - 5 AUT-DTM					
DTM - 1 Date/time/period					
UN/EDIFACT Directory 96.A C			D6 R		CRG N
A segment identifying the validation date/time.					
Segment number : 95					
UN/EDIFACT Directory 96.A			D6 Description		CRG Description
C507	Date/time/period	M	M		
2005	Date/time/period qualifier	M an..3	M	218 = Authentication/validation date/time	
2380	Date/time/period	C an..35	R		
2379	Date/time/period format qualifier	C an..3	R	102 = CCYYMMDD 203 = CCYYMMDDHHMM	
<u>Example:</u>					
DTM+218:19970630:102'					

UNT - 1 MESSAGE TRAILER						
UN/EDIFACT Directory 96.A M			D6 M		CRG M	
A service segment ending a message, giving the total number of segments in the message and the control reference number of the message.						
Segment number : 96						
UN/EDIFACT Directory 96.A			D6 Description		CRG Description	
0074	Number of segments in a message	M n..6	M			
0062	Message reference number	M an..14	M		This data element must have the same value as DE 0062 in the UNH segment, a sender-generated sequence number unique within an interchange.	
<u>Example:</u>						
UNT+96+19970630MJRF'						

4. History of changes

This CREMUL MIG, version 1.1 of August 2000 contains the following changes, as compared to the previous version:

- Chapter 1 - Introduction New section.
- Chapter 2 - Message Layout New section.
- Chapter 3 - Segment Layout Addition of section "Introduction".
- Chapter 3.2. - Segment Description Layout of table altered,
Consistency of descriptions improved.
- Chapter 4 - History of changes New section.

Changes from version 1v1 to 1v2 of November 2000:

- Chapter 3.2 – SG07 Description of Option 3 changed: SG17 is used. The single amounts in SG17 have to be summed up into SG07 when charges/allowances are not included in the transaction. This option only uses code 7 in DE 4471
- Chapter 3.2 - SG08 and SG18 ALC-C552 changed from "R" to "O"
- Chapter 3.2 – SG09, SG13 and SG19 Description in CUX segments improved (usage of currency rate base)
- Chapter 3.2 – SG15 INP-C849 changed from "R" to "O"
- Chapter 3.2 CRG description block added

Changes from version 1v2 to 1v2.1 of February 2001:

- Chapter 1.3 Description corrected
- Chapter 3.2 - SG27 Changed from "D" to "O"

Changes from version 1v2.1 to 1v3 of May 2001:

- Branching diagram, Segment list,
Segment description SG21 and 23 The UN EDIFACT structure shows a FTX segment as part of SG21. However this is inconsistent with all other financial messages. Therefore it has been decided to treat this FTX segment as part of SG23 as in all other financial messages.