

DIRDEB D.96A

Direct debit message

Recommendation of D6 EWG sub-working group Finance

for the use of the UN/EDIFACT-Message

Version 1.2.4 from January 18th, 2002

Table of contents

Table of contents	1
1. Introduction	2
1.1. Scope	2
1.1.1. Functional Definition	2
1.1.2. Field of Application	2
1.1.3. Principles.....	3
1.2. References	3
1.3. Data Segment Clarification	4
1.4. Rules for segments FII and NAD	4
1.4.1. Dependencies of FII and NAD relevant for transactions in PAYMUL and DIRDEB D.96A	4
1.4.2. Directory D.96A: Major parties involved in transaction	5
1.4.3. Logical differences between MIGs of D.96A and of D.91.2	6
1.5. Codes to be used in DE 1131 and DE 3055 (associated with DE 3434 – Institution Branch Number)	7
2. Message Layout	10
2.1. Branching Diagram	10
2.2. Message Structure	15
3. Segment Layout	19
3.1. Introduction	19
3.1.1. UN/EDIFACT Directory 96.A Block.....	19
3.1.2. D6 Description Block.....	19
3.1.3. Third Block.....	20
3.2. Segment Description	20
4. History of changes	116

1. Introduction

This specification provides the definition of the Direct debit message (DIRDEB) to be used in Electronic Data Interchange (EDI) between trading partners involved in administration, commerce and transport.

1.1. Scope

1.1.1. Functional Definition

Prior to the Direct Debit procedure, some agreement(s) would usually have been concluded :

- agreement between the Creditor and his Bank (mainly to specify the conditions of credit and the kind of direct debit).
- agreement between the Debtor and the Debtor's Bank (i.e. pre-authorization and condition of debit), or between the Creditor and the Debtor.

A Direct Debit is sent by the Creditor to the Creditor's Bank instructing it to claim specified amount(s) from the Debtor(s) and to credit the amount(s) to an account specified in the message, which the Creditor's Bank services for the Creditor in settlement of the referenced transaction(s).

Throughout this document the term 'Creditor' refers to either a Beneficiary or a Payee, likewise the term 'Debtor' refers to either an Ordering Customer or a Payor.

The term 'Bank' may be interpreted as any financial institution.

The term 'pre-authorization' refers to an agreement between a Creditor and a Debtor for

- either automatic debiting, as required,
- or for debiting unless rejected by the debtor in a period of time.

The agreement can also be made between the debtor and his bank, independently of the amount of the DIRDEB.

1.1.2. Field of Application

This message type may be applied, for both national and international settlements, but it is based on the national existing rules of the debit side.

1.1.3. Principles

- A Direct Debit may cover the financial settlement(s) of one or more commercial trade transactions, such as invoices, credit notes, debit notes, etc. It is not intended for use in securities trading.
- Several credit accounts, execution dates and currencies may be specified.
- Charges may be borne on account(s) different of the account(s) held by the Creditor.
- The Creditor's Bank may need a confirmation/authorization (AUTHOR) from the creditor to be able to process the Direct Debit Message.
- Pre-authorized and non pre-authorized direct debits shall not be mixed within the same message.
- The only way to modify a Direct Debit message is to cancel the whole message or a transaction thereof (e.g. by the use of the FINCAN message). In that respect, one to many order(s) could be cancelled within the message, avoiding to be obliged to cancel the whole message.

The cancellation of a message can only be effected by the originator of the message. The kind of cancellation is dependent upon the process of the message or a transaction of it.

1.2. References

This document is based on:

Title	Version	Remarks	Source
ISO 9735 Electronic data interchange for administration, commerce and transport (EDIFACT) – Application level syntax rules	Syntax version number: 3		http://www.iso.ch/cate/cat.html
ISO 646 Information processing – ISO 7-bit coded character set for information interchange			http://www.iso.ch/cate/cat.html
UNITED NATIONS TRADE DATA INTERCHANGE DIRECTORY (UNTDID)	D.96A	Definition DIRDEB	http://www.unece.org/trade/untdid
UNITED NATIONS TRADE DATA INTERCHANGE DIRECTORY (UNTDID)	D.00B	UNCL (codelist) only	http://www.unece.org/trade/untdid
Recommended Practice For Message Flow And Security For EDIFACT Payments (D6)	Version 2.03	D6_RecPract_2v03.pdf	http://www.edifact-wg.org

DIRDEB D.96A Direct Debit message, Recommendation of D6 Sub Working Group Finance for the use of the UN/EDIFACT Message	Version 1.0	Dirdeb_19990414.rtf	
D6 Referencing Rules and Recommendations	Version 1.1	D6_RefRules_1v01.pdf	http://www.edifact-wg.org

1.3. Data Segment Clarification

The following semantic principles applying to the message are intended to facilitate the understanding of the message:

The Direct Debit message is structured in three levels: A, B and C.

- Level A contains general data related to the whole message and is contained in Segment Groups 1, 2, 3 and 24 and the Heading/Trailing sections.
- Level B contains data from the credit side (one credit account, one currency, one execution day) and data which applies to all the dependent C levels and is contained in Segment Group 4 through Segment Group 10.
- Level C contains mainly data related to the debit side and, may contain remittance information. This data is considered as unique for each debit transaction and is contained in Segment Group 11 through Segment Group 23.

The structure of the message is designed to allow several B levels, each B level being followed by its related C levels.

1.4. Rules for segments FII and NAD

1.4.1. Dependencies of FII and NAD relevant for transactions in PAYMUL and DIRDEB D.96A

	PAYMUL level B Party Qualifier (DE 3035)	PAYMUL level C Party Qualifier (DE 3035)	DIRDEB level B Party Qualifier (DE 3035)	DIRDEB level C Party Qualifier (DE 3035)
Only FII, no NAD. C078 must contain the account holder name.	FII+OR	FII+BF	FII+BF	FII+PH

No FII, only 1 NAD. Full address is required.	<i>Not allowed</i>	NAD+BE	<i>Not allowed</i>	<i>Not allowed</i>
FII and 1 NAD; both defining the same party (account owner). FII-C078 must not contain the account holder name.	FII+OR NAD+PL	FII+BF NAD+PE	FII+BF NAD+PE	FII+PH NAD+PL
FII and 1 NAD; NAD defining a party different to the account owner in FII. FII-C078 must contain the account holder name.	FII+OR NAD+OY	FII+BF NAD+BE	FII+BF NAD+BE	FII+PH NAD+HX
FII and 2 NAD; one NAD defining the account owner (FII-C078 must not contain the account holder name) and one NAD defining a party different to the account owner in FII (full address is required).	FII+OR NAD+PL NAD+OY	FII+BF NAD+PE NAD+BE	FII+BF NAD+PE NAD+BE	FII+PH NAD+PL NAD+HX

1.4.2. Directory D.96A: Major parties involved in transaction

Message D.96A	Level B				Level C		
	Ordering customer (other than the account owner)		Account owner on the ordering side	(FII+I1)	Account owner on the receiving side		Receiving party (other than the account owner)
PAYMUL	NAD+OY	→	FII+OR NAD+PL	→	FII+BF NAD+PE	→	NAD+BE
PAYMUL	NAD+OY	→	FII+OR NAD+PL	→	FII+BQ	→	NAD+RV NAD+BE
DIRDEB	NAD+BE	→	FII+BF NAD+PE	→	FII+PH NAD+PL	→	NAD+HX

1.4.3. Logical differences between MIGs of D.96A and of D.91.2

Directory D.96A	Directory 91.2	Comment to the differences in PAYMUL D.96A and PAYORD 91.2
<i>Level B</i>		
FII+OR	FII+OR	No differences
FII+OR NAD+PL	FII+OR NAD+OY	If ordering customer and account owner (FII+OR) on the ordering side are the same, additional address details have to be added in different NAD segments: <ul style="list-style-type: none"> • In D.96A NAD+PL defines always the account owner • In 91.2 NAD+OY defines the account owner only if no NAD+PL exists
FII+OR NAD+OY	FII+OR NAD+PL NAD+OY	If ordering customer and account owner (FII+OR) on the ordering side are not the same, additional address details have to be added in different NAD segments: <ul style="list-style-type: none"> • In D.96A NAD+OY defines always an ordering party different to the account owner • In 91.2 NAD+OY defining an ordering party different to the account owner is only allowed together with an NAD+PL defining the account owner
FII+OR NAD+PL NAD+OY	FII+OR NAD+PL NAD+OY	No differences: NAD+PL defines the same party as FII+OR (=account owner), and NAD+OY defines an ordering customer other than the account owner.
<i>Level C</i>		
FII+BF	FII+BF	No differences
FII+BF NAD+PE	FII+BF NAD+BE	If final beneficiary and account owner (FII+BF) on the receiving side are the same, additional address details have to be added in different NAD segments: <ul style="list-style-type: none"> • In D.96A NAD+PE defines always the account owner • In 91.2 NAD+BE defines the account owner only if no NAD+PE exists

FII+BF NAD+BE	FII+BF NAD+PE NAD+BE	<p>If final beneficiary and account owner (FII+BF) on the receiving side are not the same, additional address details have to be added in different NAD segments:</p> <ul style="list-style-type: none"> • In D.96A NAD+BE defines always a final beneficiary different to the account owner • In 91.2 NAD+BE defining a final beneficiary different to the account owner is only allowed together with an NAD+PE defining the account owner
FII+BF NAD+PE NAD+BE	FII+BF NAD+PE NAD+BE	<p>No differences:</p> <p>NAD+PE defines the same party as FII+BF (=account owner), and</p> <p>NAD+BE defines a final beneficiary other than the account owner.</p>

1.5. Codes to be used in DE 1131 and DE 3055 (associated with DE 3434 – Institution Branch Number)

DE3434 – DE1131 (Code List Qualifier)	25 = Bank identification
	43 = CHIPS Participant ID
	44 = CHIPS Universal ID
	154 = Bank branch sorting identification
	155 = Automated clearing house
	157 = Clearing code
DE3434 – DE3055 (Code List Responsible Agency, coded)	5 = ISO (International Organization for Standardization)
	19 = FRRC (Federal Reserve Routing Code)
	108 = FR, Banque de France
	114 = US, ABA (American Bankers Association)
	118 = SE, Svenska Bankfoerenigen

119 = IT, Associazione Bancaria Italiana
121 = CH, Telekurs AG
122 = CH, Swiss Securities Clearing Corporation
124 = NO, Norwegian Bankers Ass.
125 = FI, The Finnish Bankers' Association
128 = BE, Belgian Bankers' Association
130 = DK, PBS (Pengainstitutternes Betalings Service)
131 = DE, German Bankers Association
133 = GB, Association for Payment Clearing Services
137 = AT, Verband oesterreichischer Banken und Bankiers
171 = NL, Interpay Girale Services
202 = PT, Banco de Portugal
275 = ES, Banco de España
ZA7 = TW, Taiwanese Bankers' Association (D6 code)
Zxx = If no code exists, then "Z" + "ISO 3166 two alpha country code"

These codes should be combined as indicated in the following table:

To identify a financial institution by the following code	1131 Code	3055 Code
ISO Bank Identifier Code	25	5
Fedwire Id	25	19

French Bank Code	25	108
Swedish Bank Clearing Number	157	118
Italian Bank Code	25	119
Swiss Bank Clearing Number	157	121
Norwegian Bank Code	25	124
Finnish Bank Code	25	125
Belgian Bank Code	25	128
Danish Bank Code	25	130
German Bankleitzahl	25	131
GB Bank Sort Code	154	133
Austrian Bankleitzahl	25	137
Dutch Bank Code	25	171
Portuguese Bank Code	25	202
Portuguese Clearing House Code	155	202
Spanish Bank code	25	275
Chinese Taipei Bank Code	154	ZA7 (D6 code)
CHIPS Participant ID	43	114
CHIPS Universal ID	44	114

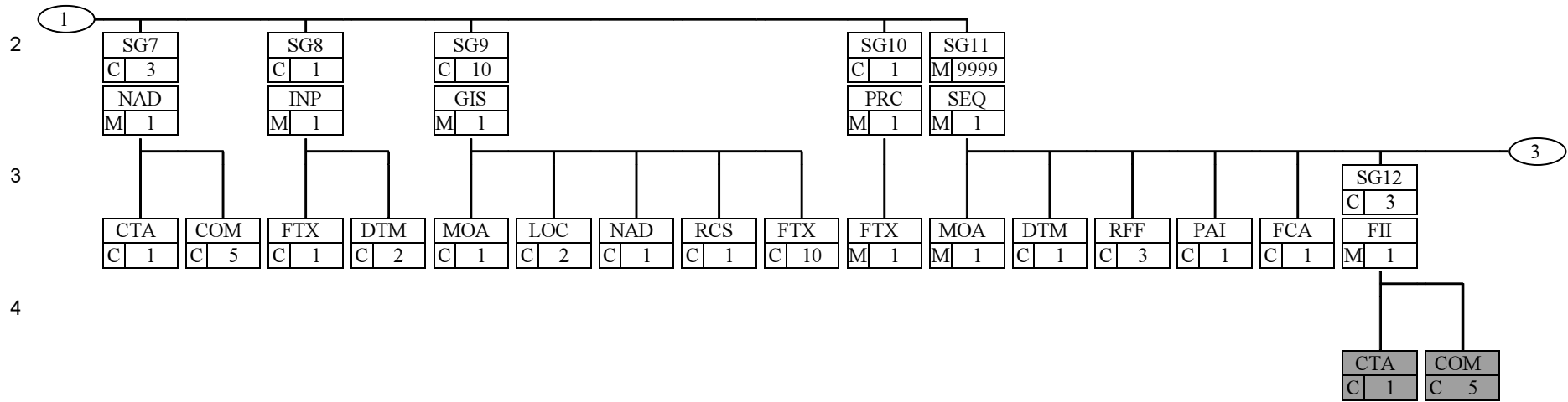

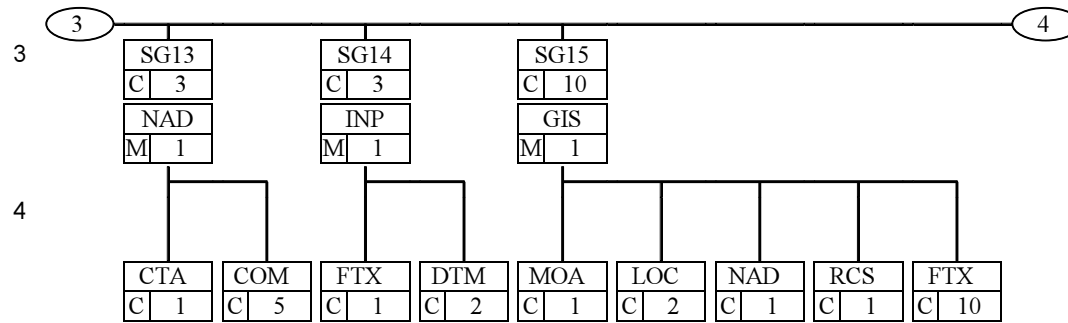

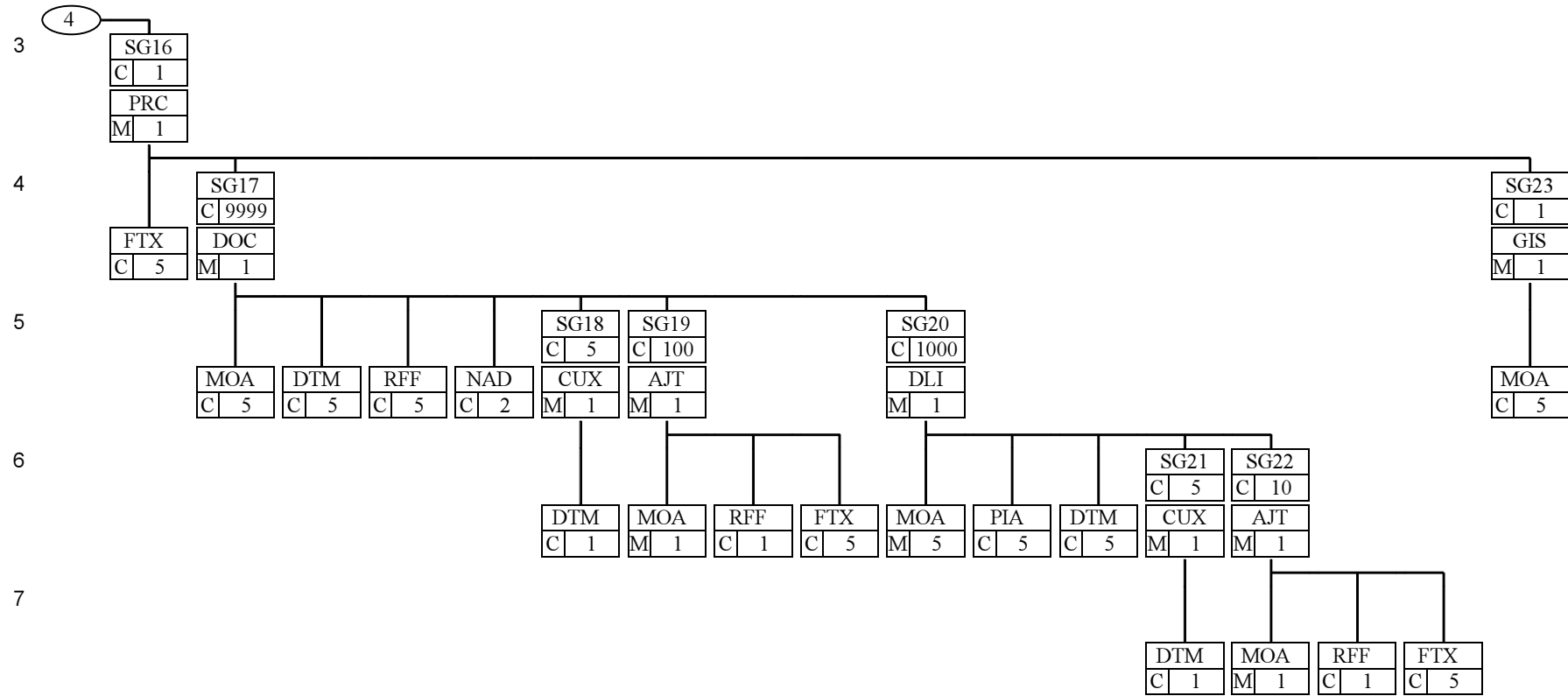

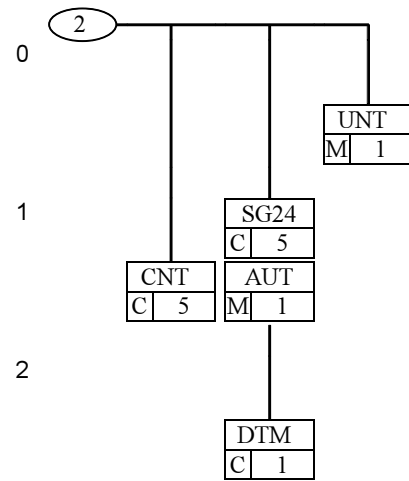

2.2. Message Structure

Pos	Tag Name	S	R
0010	UNH Message header	M	1
0020	BGM Beginning of message	M	1
0030	DTM Date/time/period	M	1
0040	BUS Business function	C	1
0050	Segment group 1	C	2
0060	RFF Reference	M	1
0070	DTM Date/time/period	C	1
0080	Segment group 2	C	5
0090	FII Financial institution information	M	1
0100	CTA Contact information	C	1
0110	COM Communication contact	C	5
0120	Segment group 3	C	3
0130	NAD Name and address	M	1
0140	CTA Contact information	C	1
0150	COM Communication contact	C	5
0160	Segment group 4	M	9999
0170	LIN Line item	M	1
0180	DTM Date/time/period	C	1
0190	RFF Reference	C	2
0200	BUS Business function	C	1
0210	FCA Financial charges allocation	C	1
0220	Segment group 5	C	1
0230	MOA Monetary amount	M	1
0240	CUX Currencies	C	1
0250	DTM Date/time/period	C	2
0260	RFF Reference	C	1
0270	Segment group 6	M	1

0280	FII	Financial institution information	M	1
0290	CTA	Contact information	C	1
0300	COM	Communication contact	C	5
0310		Segment group 7	C	3
0320	NAD	Name and address	M	1
0330	CTA	Contact information	C	1
0340	COM	Communication contact	C	5
0350		Segment group 8	C	1
0360	INP	Parties to instruction	M	1
0370	FTX	Free text	C	1
0380	DTM	Date/time/period	C	2
0390		Segment group 9	C	10
0400	GIS	General indicator	M	1
0410	MOA	Monetary amount	C	1
0420	LOC	Place/location identification	C	2
0430	NAD	Name and address	C	1
0440	RCS	Requirements and conditions	C	1
0450	FTX	Free text	C	10
0460		Segment group 10	C	1
0470	PRC	Process identification	M	1
0480	FTX	Free text	M	1
0490		Segment group 11	M	9999
0500	SEQ	Sequence details	M	1
0510	MOA	Monetary amount	M	1
0520	DTM	Date/time/period	C	1
0530	RFF	Reference	C	3
0540	PAI	Payment instructions	C	1
0550	FCA	Financial charges allocation	C	1
0560		Segment group 12	C	3
0570	FII	Financial institution information	M	1
0580	CTA	Contact information	C	1
0590	COM	Communication contact	C	5
0600		Segment group 13	C	3

0610	NAD Name and address	M	1
0620	CTA Contact information	C	1
0630	COM Communication contact	C	5
0640	—— Segment group 14	C	3
0650	INP Parties to instruction	M	1
0660	FTX Free text	C	1
0670	DTM Date/time/period	C	2
0680	—— Segment group 15	C	10
0690	GIS General indicator	M	1
0700	MOA Monetary amount	C	1
0710	LOC Place/location identification	C	2
0720	NAD Name and address	C	1
0730	RCS Requirements and conditions	C	1
0740	FTX Freetext	C	10
0750	—— Segment group 16	C	1
0760	PRC Process identification	M	1
0770	FTX Free text	C	5
0780	—— Segment group 17	C	9999
0790	DOC Document/message details	M	1
0800	MOA Monetary amount	C	5
0810	DTM Date/time/period	C	5
0820	RFF Reference	C	5
0830	NAD Name and address	C	2
0840	—— Segment group 18	C	5
0850	CUX Currencies	M	1
0860	DTM Date/time/period	C	1
0870	—— Segment group 19	C	100
0880	AJT Adjustment details	M	1
0890	MOA Monetary amount	M	1
0900	RFF Reference	C	1
0910	FTX Free text	C	5
0920	—— Segment group 20	C	1000
0930	DLI Document line identification	M	1

0940	MOA Monetary amount	M	5				
0950	PIA Additional product id	C	5				
0960	DTM Date/time/period	C	5				
0970	—— Segment group 21	C	5				
0980	CUX Currencies	M	1				
0990	DTM Date/time/period	C	1				
1000	—— Segment group 22	C	10				
1010	AJT Adjustment details	M	1				
1020	MOA Monetary amount	M	1				
1030	RFF Reference	C	1				
1040	FTX Free text	C	5				
1050	—— Segment group 23	C	1				
1060	GIS General indicator	M	1				
1070	MOA Monetary amount	C	5				
1080	CNT Control total	C	5				
1090	—— Segment group 24	C	5				
1100	AUT Authentication result	M	1				
1110	DTM Date/time/period	C	1				
1120	UNT Message trailer	M	1				

3. Segment Layout

3.1. Introduction

This section describes each segment of the UN/EDIFACT message DIRDEB.

Each segment is presented in a separate table and in the sequence in which they appear in the message.

The upper half of each table provides information about the segment or segment group concerned, the lower part of the table describes the data elements (composite and simple).

Each table is structured in three vertical blocks: UN/EDIFACT Directory 96.A, D6 and an empty block:

3.1.1. UN/EDIFACT Directory 96.A Block

The left third of the table provides information extracted from the original UN/EDIFACT Directory 96.A.

In the first line of this block, the segment or segment group tag is followed by the maximum number of occurrences.

The second line contains the (M)andatory / (C)onditional indicator at segment level, according to the UN/EDIFACT Directory 96.A

In the lower half of the table, the data element tag (composite or simple) and full name are followed by the corresponding (M)andatory / (C)onditional indicators and the format.

3.1.2. D6 Description Block

This block presents the recommendations of D6 (EWG sub-working group Finance).

Both for segment level and for data element level (simple and composite), the following status/sub-status are defined:

M	MANDATORY	The entity is mandatory and must be sent (according to directory, unchanged)
R	REQUIRED	The entity is required and must be sent
D	DEPENDENT	The entity must be sent in certain conditions, as defined by the relevant explanatory note

O	OPTIONAL	The entity is optional and may be sent at the discretion of the user
N	NOT USED	The entity is not used and should be omitted. Any data placed in an element marked with N will be ignored.

At data element level:

- The first column indicates the status as defined above (with the options M, R, D, O, N);
- The second column includes information affecting the code values as follows:

*	Restricted codelist	Code values preceded by an asterisk (*) are the only codes available for use in the given context
<blank>	Open codelist	Code values not preceded by an asterisk (*) are not restricted (they are open). The available codes are listed in the codelist of the corresponding UN/EDIFACT directory.
* R	Required code in a restricted list	Codes preceded by an “R” are required and must occur in one repetition of the corresponding segment if used.
R	Required code in an open list	Codes preceded by an “R” are required and must occur in one repetition of the corresponding segment if used.

- The third column provides additional comments and descriptions.

Note that if a segment group/segment/composite data element is flagged as “N”, all data elements within that segment group/segment/composite data element will have blank status indicators.

3.1.3. Third Block

The last block of the table describes the preferred use of the message for a group of multinational companies constituting the “Corporate Reference Group” (CRG). The CRG is established as a forum for discussion of standardisation issues. The members of the group are predominantly companies with activities in several countries and a large resource base.

3.2. Segment Description

See next page

UNH - 1 MESSAGE HEADER						
UN/EDIFACT Directory 96.A M			D6 M		CRG M	
<p>A service segment starting and uniquely identifying a message. The message type code for the Direct debit message is DIRDEB.</p> <p>Note: Direct debit messages conforming to this document must contain the following data in segment UNH, composite S009:</p> <p>Data element 0065 DIRDEB 0052 D 0054 96A 0051 UN</p>						
Segment number : 2						
UN/EDIFACT Directory 96.A			D6 Description			CRG Description
0062 Message reference number	M an..14	M			<p>This sender-generated sequence number must be unique within an interchange. Data element 0062 in the UNT segment must have the same value.</p> <p>Incorrect data in this composite DE will cause message rejection.</p> <p>DIRDEB</p> <p>D = Directory</p> <p>96A = Release 96 A</p> <p>UN = UN/ECE/TRADE/WP.4, United Nations Standard Messages (UNSM)</p> <p>FUN01G = Industry/ Country Code/ Version number/ Function, , i.e., Finance/ United Nations/ Version 1/ General</p>	
S009 MESSAGE IDENTIFIER	M	M				
0065 Message type identifier	M an..6	M	*R			
0052 Message type version number	M an..3	M	*R			
0054 Message type release number	M an..3	M	*R			
0051 Controlling agency	M an..2	M	*R			
0057 Association assigned code	C an..6	O	*			
0068 Common access reference	C an..35	N				
S010 STATUS OF THE TRANSFER	C	N				
0070 Sequence message transfer number	M n..2					
0073 First/last sequence message transfer indication	C a1					
<u>Example:</u>						
UNH+20000124AKMJRF+DIRDEB:D:96A:UN: FUN01G '						

BGM - 1 Beginning of message						
UN/EDIFACT Directory 96.A M			D6 M		D6 M	
A segment by means of which the sender must uniquely identify the DIRDEB message using its type (e.g., kind of pre-authorized instructions or not pre-authorized) and number and its function. The requirement for a response, e.g., related credit advices, may be indicated.						
Note: The identification of the DIRDEB will be passed back to the creditor for reconciliation purposes.						
Segment number : 3						
UN/EDIFACT Directory 96.A			D6 Description		CRG Description	
C002 Document/message name	C	R				
1001 Document/message name, coded	C an..3	R	*	214 = Pre-authorized direct debit(s)		
			*	238 = Non-pre-authorized direct debit(s)		
			*	243 = Pre-authorized direct debit request(s)		
			*	244 = Non-pre-authorized direct debit request(s)		
1131 Code list qualifier	C an..3	N				
3055 Code list responsible agency, coded	C an..3	N				
1000 Document/message name	C an..35	N				
1004 Document/message number	C an..35	R		Must be unique within the legally binding time of archiving EDI documents. A second DIRDEB messages with the same document number but without the code 7 in DE1225 will be rejected.		
1225 Message function, coded	C an..3	R	*	9 = Original		Only use code 9
			*	7 = Duplicate		
				If code 7 is used, then segment group 1 is required.		
4343 Response type, coded	C an..3	O	*R	AB = Message acknowledgement If the data element is missing, the acknowledgement of a message together with the responsibility for the receiver will happen as bilaterally agreed.	N	Not used
Example:						
BGM+214+3452422040+9'						

DTM - 1 Date/time/period					
UN/EDIFACT Directory 96.A M			D6 M		CRG M
A segment specifying the date and/or time the message is created.					
Segment number : 4					
UN/EDIFACT Directory 96.A			D6 Description		CRG Description
C507	Date/time/period	M	M		
2005	Date/time/period qualifier	M an..3	M	*R	137 = Document/message date/time A date in the future can be accepted given the creation of messages across different time zones.
2380	Date/time/period	C an..35	R		
2379	Date/time/period format qualifier	C an..3	R	* *	
					102 = CCYYMMDD 203 = CCYYMMDDHHMM
<u>Example:</u>					
DTM+137:20000124:102'					

BUS - 1 Business function						
UN/EDIFACT Directory 96.A C		D6 N		CRG N		
A segment identifying certain characteristics of the DIRDEB, such as, its business function. In so doing, it provides information about the message that may be used to route the message within an institution, for tariffing, or for the provision of some statistical information.						
Segment number : 5						
UN/EDIFACT Directory 96.A		D6 Description			CRG Description	
C521 Business function	C					
4027 Business function qualifier	M an..3					
4025 Business function, coded	M an..3					
1131 Code list qualifier	C an..3					
3055 Code list responsible agency, coded	C an..3					
4022 Business description	C an..70					
3279 Geographic environment, coded	C an..3					
4487 Type of financial transaction, coded	C an..3					
C551 Bank operation	C					
4383 Bank operation, coded	M an..3					
1131 Code list qualifier	C an..3					
3055 Code list responsible agency, coded	C an..3					
4463 Intra-company payment, coded	C an..3					

SG1 - 2 RFF-DTM				
UN/EDIFACT Directory 96.A C		D6 D		CRG N
A group of segments identifying a previously sent message.		This segment group is used only when DE1255 in BGM contains the code 7 (duplicate).		Not used
RFF - 1 Reference				
UN/EDIFACT Directory 96.A M		D6 M		CRG N
A segment identifying a previously sent message.		This segment contains the original BGM number of the previously sent message, regardless of whether the two BGM numbers are the same.		Not used
Segment number : 6				
UN/EDIFACT Directory 96.A		D6 Description		CRG Description
C506 Reference	M	M		
1153 Reference qualifier	M an..3	M	*R	ACW = Reference number to previous message BGM 1004 from the original message.
1154 Reference number	C an..35	R		
1156 Line number	C an..6	N		
4000 Reference version number	C an..35	N		
<u>Example:</u> RFF+ACW:4782971550'				

SG1 - 2 RFF-DTM			
DTM - 1 Date/time/period			
UN/EDIFACT Directory 96.A C		D6 O	
A segment identifying the date/time of the previously sent message.		CRG N	
Segment number : 7			
UN/EDIFACT Directory 96.A		D6 Description	
		CRG Description	
C507	Date/time/period	M	M
2005	Date/time/period qualifier	M an..3	M *R
2380	Date/time/period	C an..35	R
2379	Date/time/period format qualifier	C an..3	R *
			R *
			171 = Reference date/time
			Creation date of the original message.
			102 = CCYYMMDD
			203 = CCYYMMDDHHMM
<u>Example:</u>			
DTM+171:19991215:102'			

SG2 - 5 FII-CTA-COM				
UN/EDIFACT Directory 96.A C		D6 O		CRG N
A group of segments identifying the financial institutions involved in the direct debit, their functions and their contacts.		This segment group is used for routing purposes only.		Not used
FII - 1 Financial institution information				
UN/EDIFACT Directory 96.A M		D6 M		CRG N
A segment identifying the financial institution associated with the transaction and their functions.				Not used
Segment number : 8				
UN/EDIFACT Directory 96.A		D6 Description		CRG Description
3035 Party qualifier	M an..3	M	* *	MR = Message recipient AS = Account servicing financial institution. This code is required when code 243 or 244 are used in DE 1001 of BGM.
C078 Account identification	C	N		
3194 Account holder number	C an..35			
3192 Account holder name	C an..35			
3192 Account holder name	C an..35			
6345 Currency, coded	C an..3			
C088 Institution identification	C	R		The Bank Identifier Code may only be placed in DE 3433. The national bank/branch sorting code may only be placed in data element 3434. Data elements 3433 and 3434 are mutually exclusive.
3433 Institution name identification	C an..11	D		
1131 Code list qualifier	C an..3	D	*R	25 = Bank identification
3055 Code list responsible agency, coded	C an..3	D	*R	5 = ISO (International Organization for Standardization)
3434 Institution branch number	C an..17	D		
1131 Code list qualifier	C an..3	D	*	The allowed combinations of the codes of DE1131 and 3055 are stated in Section 1.5. of this MIG.
3055 Code list responsible agency, coded	C an..3	D	*	The allowed combinations of the codes of DE1131 and 3055 are stated in Section 1.5. of this MIG.
3432 Institution name	C an..70	N		
3436 Institution branch place	C an..70	N		
3207 Country, coded	C an..3	D		ISO 3166 two alpha country code. This DE is used when DE 3434 is used and no country is mentioned in its associated DE3055.
<u>Example:</u> FII+MR++DEUTDEFF:25:5'				

SG2 - 5 FII-CTA-COM			
CTA - 1 Contact information			
UN/EDIFACT Directory 96.A C		D6 N	
A segment identifying a person or a department for the party specified in the leading FII segment to whom communication should be directed.		CRG N	
Segment number : 9			
UN/EDIFACT Directory 96.A		D6 Description	
CRG Description			
3139	Contact function, coded	C an..3	
C056	Department or employee details	C	
3413	Department or employee identification	C an..17	
3412	Department or employee	C an..35	

SG2 - 5 FII-CTA-COM			
COM - 5 Communication contact			
UN/EDIFACT Directory 96.A C		D6 N	
UN/EDIFACT Directory 96.A C		CRG N	
A segment identifying communication type(s) and number(s) of person(s) or department(s) specified in the associated CTA segment.			
Segment number : 10			
UN/EDIFACT Directory 96.A		D6 Description	
UN/EDIFACT Directory 96.A		CRG Description	
C076	Communication contact	M	
3148	Communication number	M an..512	
3155	Communication channel qualifier	M an..3	

SG3 - 3 NAD-CTA-COM			
UN/EDIFACT Directory 96.A C	D6 O	CRG N	
A group of segments identifying the name(s) and address(es) of each non-financial party involved in the transaction, their functions and their contacts.	This segment group is used for routing purposes only.		Not used
NAD - 1 Name and address			
UN/EDIFACT Directory 96.A M	D6 M	CRG N	
A segment identifying names and addresses of the parties associated with the direct debit, in coded or uncoded form, and their functions.			Not used
Segment number : 11			
UN/EDIFACT Directory 96.A	D6 Description		CRG Description
3035 Party qualifier	M an..3	M * *	MS = Document/message issuer/sender HQ = Account owner. The usage of this code is subject to national agreement.
C082 Party identification details	C	D	Either C082 or DE's C080, C059, 3164, 3229, 3251 and 3207 are used. In this composite only bilaterally agreed codes are allowed.
3039 Party id. identification	M an..35	M	
1131 Code list qualifier	C an..3	D	
3055 Code list responsible agency, coded	C an..3	D	
C058 Name and address	C	N	
3124 Name and address line	M an..35		
3124 Name and address line	C an..35		
3124 Name and address line	C an..35		
3124 Name and address line	C an..35		
3124 Name and address line	C an..35		
C080 Party name	C	D	Either C082 or DE's C080, C059, 3164, 3229, 3251 and 3207 are used. Use of structured name and address has to be allowed by bilateral agreement.
3036 Party name	M an..35	M	
3036 Party name	C an..35	O	
3036 Party name	C an..35	O	
3036 Party name	C an..35	N	
3036 Party name	C an..35	N	
3045 Party name format, coded	C an..3	N	
C059 Street	C	D	
3042 Street and number/p.o. box	M an..35	M	
3042 Street and number/p.o. box	C an..35	O	
3042 Street and number/p.o. box	C an..35	O	

3042	Street and number/p.o. box	C an..35	N			
3164	City name	C an..35	D			
3229	Country sub-entity identification	C an..9	D			
3251	Postcode identification	C an..9	D			
3207	Country, coded	C an..3	D	ISO 3166 two alpha country code.		
<u>Example:</u>						
NAD+MS+2729712345832:160:9'						

SG3 - 3 NAD-CTA-COM				
CTA - 1 Contact information				
UN/EDIFACT Directory 96.A C		D6 O		CRG N
A segment identifying a person or a department for the party specified in the leading NAD segment and to whom communication should be directed.			Not used	
Segment number : 12				
UN/EDIFACT Directory 96.A		D6 Description		CRG Description
3139	Contact function, coded	C an..3	R *R	IC = Information contact
C056	Department or employee details	C	R	
3413	Department or employee identification	C an..17	N	
3412	Department or employee	C an..35	R	Name of the department or employee in free text form.
<u>Example:</u>				
CTA+IC+:M WITZIGMANN'				

SG3 - 3 NAD-CTA-COM			
COM - 5 Communication contact			
UN/EDIFACT Directory 96.A C		D6 O	
A segment identifying communication type(s) and number(s) of person(s) or department(s) specified in the associated CTA segment.		CRG N	
Not used			
Segment number : 13			
UN/EDIFACT Directory 96.A		D6 Description	
CRG Description			
C076 Communication contact	M	M	
3148 Communication number	M an..512	M	
3155 Communication channel qualifier	M an..3	M	
When character sets UNOA or UNOB are used, the @ in e-mail addresses must be shown with (at) (parenthesis, at, parenthesis), e.g. <john.smith(at)abc.com>. FX = Telefax TE = Telephone EM = Electronic mail TL = Telex The use of other codes must be bilaterally agreed.			
<u>Example:</u> COM+49696731286:TE'			

SG4 - 9999 LIN-DTM-RFF-BUS-FCA-SG5-SG6-SG7-SG8-SG9-SG10-SG11						
UN/EDIFACT Directory 96.A M		D6 M			CRG M	
A group of segments containing information regarding the credit side of the transaction and details which are pertinent to all direct debits specified within the group. Certain payment details may be provided either in segment group 4 or in segment group 11, but not in both.		This B-level contains sorting criteria for transactions contained in the C-level: the account number to be credited, the DTM information in SG4, the currency of the amount to be transferred, the monetary amount type and the geographic environment have to be the same. If any additional DTM information is present in SG11, it has to be the same in each C-level of this B-level.				
LIN - 1 Line item						
UN/EDIFACT Directory 96.A M		D6 M			CRG M	
A segment identifying the beginning of the credit side of the transaction (B level) by a sequential line number, which may also be used for reconciliation purposes.						
Segment number : 14						
UN/EDIFACT Directory 96.A		D6 Description			CRG Description	
1082	Line item number	C n..6	R			
1229	Action request/notification, coded	C an..3	O	* *		N Not used
C212	Item number identification	C	N			
7140	Item number	C an..35				
7143	Item number type, coded	C an..3				
1131	Code list qualifier	C an..3				
3055	Code list responsible agency, coded	C an..3				
C829	Sub-line information	C	N			
5495	Sub-line indicator, coded	C an..3				
1082	Line item number	C n..6				
1222	Configuration level	C n..2	N			
7083	Configuration, coded	C an..3	N			
<u>Example:</u>						
LIN+1'						

SG4 - 9999 LIN-DTM-RFF-BUS-FCA-SG5-SG6-SG7-SG8-SG9-SG10-SG11					
DTM - 1 Date/time/period					
UN/EDIFACT Directory 96.A C			D6 R		CRG R
A segment identifying the date, at which an order has been requested to be executed or acted upon.					
Segment number : 15					
UN/EDIFACT Directory 96.A			D6 Description		CRG Description
C507	Date/time/period	M	M		
2005	Date/time/period qualifier	M an..3	M	*R	203 = Execution date/time, requested
2380	Date/time/period	C an..35	R		
2379	Date/time/period format qualifier	C an..3	R	*R	102 = CCYYMMDD 203 = CCYYMMDDHHMM
<u>Example:</u>					
DTM+203:20000126:102'					

SG4 - 9999 LIN-DTM-RFF-BUS-FCA-SG5-SG6-SG7-SG8-SG9-SG10-SG11				
RFF - 2 Reference				
UN/EDIFACT Directory 96.A C		D6 R		CRG R
A segment specifying reference of the single credit amount on the credit side of the transaction (B level). Note: The identification will be passed back to the creditor for reconciliation purposes.				
Segment number : 16				
UN/EDIFACT Directory 96.A		D6 Description		CRG Description
C506 Reference	M	M		
1153 Reference qualifier	M an..3	M	*R	AKJ = Direct debit reference For more information see D6 Referencing Rules and Recommendations.
			*	CT = Contract number Contract number between creditor and the creditors financial institution (or agents) which allows the creditor to raise direct debits.
1154 Reference number	C an..35	R		
1156 Line number	C an..6	N		
4000 Reference version number	C an..35	N		
<u>Example:</u> RFF+AKJ:3250527841'				

SG4 - 9999 LIN-DTM-RFF-BUS-FCA-SG5-SG6-SG7-SG8-SG9-SG10-SG11			
BUS - 1 Business function			
UN/EDIFACT Directory 96.A C		D6 D	
A segment identifying certain characteristics of the direct debits stored on the debit side of the transaction (C level), such as business function.		The absence of this segment means that all the transactions within this B-level are (domestic) clean payments.	
CRG D			
This segment should not be used because ideally the distinction between domestic and international payments should be done on transaction/C-level (e.g., currency, bank identification, country code). Currently, this is not possible due to legal/regulatory limitations in some countries and it may be necessary to identify whether the batch is domestic or international within this BUS segment. However, this is not desirable in the long term.			
Segment number : 17			
UN/EDIFACT Directory 96.A		D6 Description	
CRG Description			
C521 Business function	C	O	
4027 Business function qualifier	M an..3	M	*R 1 = Underlying business function
4025 Business function, coded	M an..3	M	REN= Rent
1131 Code list qualifier	C an..3	O	
3055 Code list responsible agency, coded	C an..3	O	
4022 Business description	C an..70	O	
3279 Geographic environment, coded	C an..3	R	* DO = Domestic
			* DR = Domestic with regulatory information required
			* IN = International
			* IR = International with regulatory information required
			* IS = European Union - ECBS Direct Debits.
4487 Type of financial transaction, coded	C an..3	O	*R 1 = Clean payment
C551 Bank operation	C	O	This composite may be used if there are different (national) direct debit schemes to choose from.
4383 Bank operation, coded	M an..3	M	
1131 Code list qualifier	C an..3	O	
3055 Code list responsible agency, coded	C an..3	O	
4463 Intra-company payment, coded	C an..3	O	*R 1 = Intra-company payment
<u>Example:</u>			
BUS+1:REN+DO'			

SG4 - 9999 LIN-DTM-RFF-BUS-FCA-SG5-SG6-SG7-SG8-SG9-SG10-SG11						
FCA - 1 Financial charges allocation						
UN/EDIFACT Directory 96.A C			D6 D		CRG N	
A segment specifying the method for allocation of charges and allowances and identifying the creditor's account to which such charges or allowances should be directed where it is different from the principal account. This constitutes a default specification and is mutually exclusive with the FCA segment in Segment Group 11.			This segment is mutually exclusive with the FCA segment in level C.		Not used	
Segment number : 18						
UN/EDIFACT Directory 96.A			D6 Description		CRG Description	
4471 Settlement, coded	M an..3	M	*	15 = All charges borne by payor - or debtor		
			*	14 = Each pay own cost		
			*	13 = All charges borne by payee (or originator of DIRDEB)		
C878 Charge/allowance account	C	O		The usage of this composite is subject to bilateral agreement.		
3434 Institution branch number	M an..17	M		National identification of the financial institution in coded form.		
1131 Code list qualifier	C an..3	R	*	The allowed combinations of the codes of DE1131 and 3055 are stated in Section 1.5. of this MIG.		
3055 Code list responsible agency, coded	C an..3	R	*	The allowed combinations of the codes of DE1131 and 3055 are stated in Section 1.5. of this MIG.		
3194 Account holder number	C an..35	R				
6345 Currency, coded	C an..3	O		ISO 4217 three alpha currency code.		
Example:						
FCA+13'						

SG4 - 9999 LIN-DTM-RFF-BUS-FCA-SG5-SG6-SG7-SG8-SG9-SG10-SG11				
SG5 - 1 MOA-CUX-DTM-RFF				
UN/EDIFACT Directory 96.A C		D6 R		
A group of segments containing the currency of the single amounts on the debit side of the transaction (C level), currency to be collected, plus the total of all single amounts of the debit side of the transaction (C level).				
MOA - 1 Monetary amount				
UN/EDIFACT Directory 96.A M		D6 M		
		The amount specified in this segment is the (batch) amount to be credited to the account identified in segment group 6, and must be equal to the sum of (individual) amounts of the MOA segments in segment group 11.		
Segment number : 19				
UN/EDIFACT Directory 96.A		D6 Description		
		CRG Description		
C516 Monetary amount	M	M	<p>9 = Amount due/amount payable 57 = Equivalent amount The same code must be used in each MOA segment of SG11. The decimal separator is either a comma or a dot. No other delimiters, e.g., thousands separators, are allowed. ISO 4217 three alpha currency code. If code 57 is used in DE 5025, , this DE contains the reference currency and the following CUX segment is required and contains the currency of the equivalent amount in the first occurrence of C504 and the currency of the amount to be transferred in the second occurrence of C504.</p>	
5025 Monetary amount type qualifier	M an..3	M *		Only use code 9
5004 Monetary amount	C n..18	R *		
6345 Currency, coded	C an..3	R		
6343 Currency qualifier	C an..3	N		
4405 Status, coded	C an..3	N		
<u>Example:</u>				
MOA+9:430000,3:EUR'				

SG4 - 9999 LIN-DTM-RFF-BUS-FCA-SG5-SG6-SG7-SG8-SG9-SG10-SG11			
SG5 - 1 MOA-CUX-DTM-RFF			
CUX - 1 Currencies			
UN/EDIFACT Directory 96.A C		D6 D	
UN/EDIFACT Directory 96.A C		CRG N	
A segment specifying the source currency and the target currency of the transaction, when they are different. The rate of exchange is solely used when previously agreed between the creditor and the creditor's bank.		This segment is used when code 57 (equivalent amount) is used in DE5025 of the preceding MOA segment to specify the currency to be transferred. <u>Calculation formula:</u> <i>Case 1) Base rate is indicated next to reference currency:</i> Transaction amount = MOA amount * (exchange rate/rate base) <i>Case 2) Base rate is indicated next to target currency:</i> Transaction amount = MOA amount / (exchange rate/rate base)	
Segment number : 20			
UN/EDIFACT Directory 96.A		D6 Description	
UN/EDIFACT Directory 96.A		CRG Description	
C504 Currency details	C	R	
6347 Currency details qualifier	M an..3	M *R	2 = Reference currency. This is the source currency in DE 6345 when qualified by code 57 in DE 5025, in the previous MOA segment. ISO 4217 three alpha currency code.
6345 Currency, coded	C an..3	R	
6343 Currency qualifier	C an..3	N	
6348 Currency rate base	C n..4	D	This DE is used only when an exchange rate is quoted in DE 5402. It is mutually exclusive with DE 6348 in the following C504. * 1 = the rate base is 1 * 100 = the rate base is 100 * 1000 = the rate base is 1000
C504 Currency details	C	R	
6347 Currency details qualifier	M an..3	M *R	3 = Target currency. This is the currency of the amount to be transferred. ISO 4217 three alpha currency code.
6345 Currency, coded	C an..3	R	
6343 Currency qualifier	C an..3	N	

6348	Currency rate base	C n..4	D	This DE is used only when an exchange rate is quoted in DE 5402. It is mutually exclusive with DE 6348 in the previous C504. * 1 = the rate base is 1 * 100 = the rate base is 100 * 1000 = the rate base is 1000
5402	Rate of exchange	C n..12	O	
6341	Currency market exchange, coded	C an..3	N	
<u>Example:</u> CUX+2:EUR+3:USD'				

SG4 - 9999 LIN-DTM-RFF-BUS-FCA-SG5-SG6-SG7-SG8-SG9-SG10-SG11					
SG5 - 1 MOA-CUX-DTM-RFF					
DTM - 2 Date/time/period					
UN/EDIFACT Directory 96.A C		D6 D		CRG N	
A segment identifying the effective date and/or time the rate of exchange was fixed. The other occurrence identifies the reference date.		This segment is used when an exchange rate contract/deal number is to be given in the next RFF segment.		Not used	
Segment number : 21					
UN/EDIFACT Directory 96.A		D6 Description		CRG Description	
C507 Date/time/period	M	M			
2005 Date/time/period qualifier	M an..3	M	*R	171 = Reference date/time - usage of this segment requires the use of the following RFF segment.	
2380 Date/time/period	C an..35	R			
2379 Date/time/period format qualifier	C an..3	R	*	102 = CCYMMDD Code 102 is recommended. 203 = CCYMMDDHHMM	
<u>Example:</u> DTM+171:19970630:102'					

SG4 - 9999 LIN-DTM-RFF-BUS-FCA-SG5-SG6-SG7-SG8-SG9-SG10-SG11			
SG5 - 1 MOA-CUX-DTM-RFF			
RFF - 1 Reference			
UN/EDIFACT Directory 96.A C		D6 D	
A segment identifying other transactions to which funds associated with the direct debit are related such as separate foreign exchange deal.		This segment is used when an exchange rate contract/deal number is to be given.	
CRG N			
Not used			
Segment number : 22			
UN/EDIFACT Directory 96.A		D6 Description	
CRG Description			
C506 Reference	M	M	
1153 Reference qualifier	M an..3	M	ACX = Banker's acceptance FX = Foreign exchange contract number
1154 Reference number	C an..35	R	
1156 Line number	C an..6	N	
4000 Reference version number	C an..35	N	
<u>Example:</u>			
RFF+FX:926744'			

SG4 - 9999 LIN-DTM-RFF-BUS-FCA-SG5-SG6-SG7-SG8-SG9-SG10-SG11						
SG6 - 1 FII-CTA-COM						
UN/EDIFACT Directory 96.A M		D6 M				
A group of segments containing the account servicing bank including the account to be credited. If the creditor is not quoted separately in the NAD segment on the credit side of the transaction (B level), then this group also contains the information of the creditor.		A group of segments containing the beneficiary's bank including the account to be credited. If the creditor is not quoted separately in a NAD segment, then this group must contain the information about the creditor.				
FII - 1 Financial institution information						
UN/EDIFACT Directory 96.A M		D6 M				
A segment identifying the financial institution and relevant account number associated with the transaction, and their functions.		This segment identifies the creditor's bank as well as at least the beneficiary's account identification.				
Bank account definition varies with countries as it sometimes includes the national bank/branching sorting code and sometimes not, often leading to errors. The correct implementation is to have one single string. However for the time being it can be split if agreed nationally. Please also refer to CRG document with examples (available at http://www1.stuzza.at/crg/migs/fii-seg.doc).						
Segment number : 23						
UN/EDIFACT Directory 96.A		D6 Description				
CRG Description						
3035 Party qualifier	M an..3	M	*R	BF = Beneficiary's bank		
C078 Account identification	C	R				
3194 Account holder number	C an..35	R		The account number should be entered according to the national account number scheme.		
3192 Account holder name	C an..35	D		If an IBAN is used, it should be present in this DE. Identifying the name and place of the account holder is mandatory in some countries. If the beneficiary is different to the account holder, the beneficiary is to be identified in the NAD segment of either B- or -C levels; the B- and C-levels are mutually exclusive in this case.		
3192 Account holder name	C an..35	O		The account holder name (continued).		
6345 Currency, coded	C an..3	O		The ISO 4217 three alpha currency code.		

C088 Institution identification	C	D		This composite DE is not needed in some countries. BIC codes are to be mapped into 3433 and national codes in 3434. They are not mutually exclusive, but the following priority rule should be followed: 1. IBAN in 3194 2. Bank account no. in 3194 and national bank identification in 3434 / 1131 / 3055 3. Bank account no. in 3194 and international bank identification (BIC) in 3433 / 1131 / 3055 In case of contradiction the definiton with highesy priority will be used.
3433 Institution name identification	C an..11	D		International identification of the financial institution in coded form.
1131 Code list qualifier	C an..3	D	*R	25 = Bank identification
3055 Code list responsible agency, coded	C an..3	D	*R	5 = ISO (International Organization for Standardization)
3434 Institution branch number	C an..17	D		National identification of the financial institution in coded form.
1131 Code list qualifier	C an..3	D	*	The allowed combinations of the codes of DE1131 and 3055 are stated in Section 1.5. of this MIG.
3055 Code list responsible agency, coded	C an..3	D	*	The allowed combinations of the codes of DE1131 and 3055 are stated in Section 1.5. of this MIG.
3432 Institution name	C an..70	N		
3436 Institution branch place	C an..70	N		
3207 Country, coded	C an..3	D		ISO 3166 two alpha country code. This data element should be used unless an IBAN is included in DE3194.
<u>Example:</u> FII+BF+5087431200:HOECHST AG:FRANKFURT:EUR+:::50070010:25:131+DE'				

SG4 - 9999 LIN-DTM-RFF-BUS-FCA-SG5-SG6-SG7-SG8-SG9-SG10-SG11			
SG6 - 1 FII-CTA-COM			
CTA - 1 Contact information			
UN/EDIFACT Directory 96.A C		D6 N	
UN/EDIFACT Directory 96.A C		CRG N	
A segment identifying a person or a department for the party specified in the leading FII segment to whom communication should be directed.			
Segment number : 24			
UN/EDIFACT Directory 96.A		D6 Description	
UN/EDIFACT Directory 96.A		CRG Description	
3139	Contact function, coded	C an..3	
C056	Department or employee details	C	
3413	Department or employee identification	C an..17	
3412	Department or employee	C an..35	

SG4 - 9999 LIN-DTM-RFF-BUS-FCA-SG5-SG6-SG7-SG8-SG9-SG10-SG11			
SG6 - 1 FII-CTA-COM			
COM - 5 Communication contact			
UN/EDIFACT Directory 96.A C		D6 N	
UN/EDIFACT Directory 96.A C		CRG N	
A segment identifying communication type(s) and number(s) of person(s) or department(s) specified in the associated CTA segment.			
Segment number : 25			
UN/EDIFACT Directory 96.A		D6 Description	
UN/EDIFACT Directory 96.A		CRG Description	
C076	Communication contact	M	
3148	Communication number	M an..512	
3155	Communication channel qualifier	M an..3	

SG4 - 9999 LIN-DTM-RFF-BUS-FCA-SG5-SG6-SG7-SG8-SG9-SG10-SG11			
SG7 - 3 NAD-CTA-COM			
UN/EDIFACT Directory 96.A C	D6 O	CRG N	
A group of segments identifying the creditor. Furthermore, one contactparty can also be quoted in this group.	This segment group is to be used by bilateral agreement only.		Not used
NAD - 1 Name and address			
UN/EDIFACT Directory 96.A M	D6 M	CRG N	
A segment identifying name and address of the non-financial institutions associated with the credit side of the transaction (B level).	This segment is mutually exclusive with the NAD segment of the same party qualifier in level C.		Not used
Segment number : 26			
UN/EDIFACT Directory 96.A	D6 Description		CRG Description
3035 Party qualifier	M an..3	M * *	BE = Beneficiary PE = Payee For more information about dependencies, refer to Section 1.4. of this MIG.
C082 Party identification details	C	O	
3039 Party id. identification	M an..35	M	
1131 Code list qualifier	C an..3	O	
3055 Code list responsible agency, coded	C an..3	O	
C058 Name and address	C	D	Either C058 or DE's C080, C059, 3164, 3229, 3251 and 3207 are used. Unstructured specification is not recommended.
3124 Name and address line	M an..35	M	
3124 Name and address line	C an..35	O	
3124 Name and address line	C an..35	O	
3124 Name and address line	C an..35	O	
3124 Name and address line	C an..35	O	
C080 Party name	C	D	Either C058 or DE's C080, C059, 3164, 3229, 3251 and 3207 are used.
3036 Party name	M an..35	M	
3036 Party name	C an..35	O	
3036 Party name	C an..35	O	
3036 Party name	C an..35	O	
3036 Party name	C an..35	O	
3045 Party name format, coded	C an..3	O	
C059 Street	C	D	
3042 Street and number/p.o. box	M an..35	M	
3042 Street and number/p.o. box	C an..35	O	
3042 Street and number/p.o. box	C an..35	O	

3042	Street and number/p.o. box	C an..35	O			
3164	City name	C an..35	D			
3229	Country sub-entity identification	C an..9	D			
3251	Postcode identification	C an..9	D			
3207	Country, coded	C an..3	D	Country of the identified party. ISO 3166 two alpha country code.		
<u>Example:</u>						
NAD+BE+++GLOBAL CONSULTING GMBH++FRANKFURT+++DE'						

SG4 - 9999 LIN-DTM-RFF-BUS-FCA-SG5-SG6-SG7-SG8-SG9-SG10-SG11				
SG7 - 3 NAD-CTA-COM				
CTA - 1 Contact information				
UN/EDIFACT Directory 96.A C		D6 O		CRG N
A segment identifying a person or a department for the party specified in the leading NAD segment to whom communication should be directed.				Not used
Segment number : 27				
UN/EDIFACT Directory 96.A		D6 Description		CRG Description
3139 Contact function, coded	C an..3	R	*R	IC = Information contact
C056 Department or employee details	C	R		
3413 Department or employee identification	C an..17	N		
3412 Department or employee	C an..35	R		The name of the department or employee in free text form.
<u>Example:</u>				
CTA+IC+:HELGA SCHMITT'				

SG4 - 9999 LIN-DTM-RFF-BUS-FCA-SG5-SG6-SG7-SG8-SG9-SG10-SG11			
SG7 - 3 NAD-CTA-COM			
COM - 5 Communication contact			
UN/EDIFACT Directory 96.A C		D6 O	
UN/EDIFACT Directory 96.A C		CRG N	
A segment identifying communication type(s) and number(s) of person(s) or department(s) specified in the associated CTA segment.		Not used	
Segment number : 28			
UN/EDIFACT Directory 96.A		D6 Description	
UN/EDIFACT Directory 96.A		CRG Description	
C076 Communication contact	M	M	When character sets UNOA or UNOB are used, the @ in e-mail addresses must be shown with (at) (parenthesis, at, parenthesis), e.g. <john.smith(at)abc.com>.
3148 Communication number	M an..512	M	
3155 Communication channel qualifier	M an..3	M	
<u>Example:</u>			
COM+49693877300:TE'			

SG4 - 9999 LIN-DTM-RFF-BUS-FCA-SG5-SG6-SG7-SG8-SG9-SG10-SG11			
SG8 - 1 INP-FTX-DTM			
UN/EDIFACT Directory 96.A C		D6 O	
A group of segments containing instructions from the creditor relating to parties identified in the NAD and FII segments. It specifies action to be taken by the identified parties, and the date (and optionally time) by which such action needs to be taken.		The specifications of this segment group can be determined nationally.	
		CRG N	
		Not used	
INP - 1 Parties to instruction			
UN/EDIFACT Directory 96.A M		D6 M	
A segment identifying the party to enact the instruction and the parties to be contacted. It specifies where appropriate the instruction in coded form.			
		CRG N	
		Not used	
Segment number : 29			
UN/EDIFACT Directory 96.A		D6 Description	
CRG Description			
C849 Parties to instruction	C	O	
3301 Party enacting instruction identification	M an..17	M	
3285 Recipient of the instruction identification	C an..17	O	
C522 Instruction	C	O	
4403 Instruction qualifier	M an..3	M	
4401 Instruction, coded	C an..3	O	
1131 Code list qualifier	C an..3	O	
3055 Code list responsible agency, coded	C an..3	O	
4400 Instruction	C an..35	O	
C850 Status of instruction	C	O	
4405 Status, coded	M an..3	M	
3036 Party name	C an..35	O	
1229 Action request/notification, coded	C an..3	O	

SG4 - 9999 LIN-DTM-RFF-BUS-FCA-SG5-SG6-SG7-SG8-SG9-SG10-SG11				
SG8 - 1 INP-FTX-DTM				
FTX - 1 Free text				
UN/EDIFACT Directory 96.A C		D6 O		CRG N
A segment providing free text instruction relating to the associated INP segment.				Not used
Segment number : 30				
UN/EDIFACT Directory 96.A		D6 Description		CRG Description
4451	Text subject qualifier	M an..3	M	*R AAG = Party instructions
4453	Text function, coded	C an..3	O	
C107	Text reference	C	O	
4441	Free text, coded	M an..3	O	
1131	Code list qualifier	C an..3	O	
3055	Code list responsible agency, coded	C an..3	O	
C108	Text literal	C	O	
4440	Free text	M an..70	M	
4440	Free text	C an..70	O	
4440	Free text	C an..70	O	
4440	Free text	C an..70	O	
4440	Free text	C an..70	O	
3453	Language, coded	C an..3	O	

SG4 - 9999 LIN-DTM-RFF-BUS-FCA-SG5-SG6-SG7-SG8-SG9-SG10-SG11			
SG8 - 1 INP-FTX-DTM			
DTM - 2 Date/time/period			
UN/EDIFACT Directory 96.A C		D6 O	
UN/EDIFACT Directory 96.A C		CRG N	
A segment specifying the earliest and latest dates and/or times by which the instruction specified in the INP and/or FTX segment(s) needs to be carried out.		Not used	
Segment number : 31			
UN/EDIFACT Directory 96.A		D6 Description	
UN/EDIFACT Directory 96.A		CRG Description	
C507 Date/time/period	M	M	
2005 Date/time/period qualifier	M an..3	M	
2380 Date/time/period	C an..35	O	
2379 Date/time/period format qualifier	C an..3	O	

SG4 - 9999 LIN-DTM-RFF-BUS-FCA-SG5-SG6-SG7-SG8-SG9-SG10-SG11			
SG9 - 10 GIS-MOA-LOC-NAD-RCS-FTX			
UN/EDIFACT Directory 96.A C		D6 O	
A group of segments providing information for subsequent use by regulatory authorities requiring statistical and other types of data. It also identifies the regulatory authority for which the information is intended followed by the information itself.		The specifications of this segment group are to be determined on unilateral regulatory reporting requirements.	
CRG N			
Not used			
GIS - 1 General indicator			
UN/EDIFACT Directory 96.A M		D6 M	
A segment identifying what processing should be completed for regulatory authorities.		The contents of this segment are to be determined nationally due to cross-border regulatory reporting or central bank requirements.	
CRG N			
Not used			
Segment number : 32			
UN/EDIFACT Directory 96.A		D6 Description	
CRG Description			
C529 Processing indicator	M	M	
7365 Processing indicator, coded	M an..3	M	
1131 Code list qualifier	C an..3	O	
3055 Code list responsible agency, coded	C an..3	O	
7187 Process type identification	C an..17	O	

SG4 - 9999 LIN-DTM-RFF-BUS-FCA-SG5-SG6-SG7-SG8-SG9-SG10-SG11			
SG9 - 10 GIS-MOA-LOC-NAD-RCS-FTX			
MOA - 1 Monetary amount			
UN/EDIFACT Directory 96.A C		D6 O	
A segment giving the amount and the currency of each transaction to be reported.		The contents of this segment are to be determined nationally due to cross-border regulatory reporting or central bank requirements.	
CRG N			
Segment number : 33			
UN/EDIFACT Directory 96.A		D6 Description	
CRG Description			
C516 Monetary amount	M	M	
5025 Monetary amount type qualifier	M an..3	M	
5004 Monetary amount	C n..18	O	
6345 Currency, coded	C an..3	O	
6343 Currency qualifier	C an..3	O	
4405 Status, coded	C an..3	O	

SG4 - 9999 LIN-DTM-RFF-BUS-FCA-SG5-SG6-SG7-SG8-SG9-SG10-SG11			
SG9 - 10 GIS-MOA-LOC-NAD-RCS-FTX			
LOC - 2 Place/location identification			
UN/EDIFACT Directory 96.A C		D6 O	
A segment giving the different origins/destinations (places) of goods/investment/services.		The contents of this segment are to be determined nationally due to cross-border regulatory reporting or central bank requirements.	
Segment number : 34			
UN/EDIFACT Directory 96.A		D6 Description	
		CRG Description	
3227	Place/location qualifier	M an..3	M
C517	Location identification	C	O
3225	Place/location identification	C an..25	O
1131	Code list qualifier	C an..3	O
3055	Code list responsible agency, coded	C an..3	O
3224	Place/location	C an..70	O
C519	Related location one identification	C	O
3223	Related place/location one identification	C an..25	O
1131	Code list qualifier	C an..3	O
3055	Code list responsible agency, coded	C an..3	O
3222	Related place/location one	C an..70	O
C553	Related location two identification	C	O
3233	Related place/location two identification	C an..25	O
1131	Code list qualifier	C an..3	O
3055	Code list responsible agency, coded	C an..3	O
3232	Related place/location two	C an..70	O
5479	Relation, coded	C an..3	O

SG4 - 9999 LIN-DTM-RFF-BUS-FCA-SG5-SG6-SG7-SG8-SG9-SG10-SG11			
SG9 - 10 GIS-MOA-LOC-NAD-RCS-FTX			
NAD - 1 Name and address			
UN/EDIFACT Directory 96.A C		D6 O	
A segment identifying a party related to the associated informative text.		The contents of this segment are to be determined nationally due to cross-border regulatory reporting or central bank requirements.	
CRG N			
Not used			
Segment number : 35			
UN/EDIFACT Directory 96.A		D6 Description	
		CRG Description	
3035 Party qualifier	M an..3	M	
C082 Party identification details	C	O	
3039 Party id. identification	M an..35	M	
1131 Code list qualifier	C an..3	O	
3055 Code list responsible agency, coded	C an..3	O	
C058 Name and address	C	O	
3124 Name and address line	M an..35	M	
3124 Name and address line	C an..35	O	
3124 Name and address line	C an..35	O	
3124 Name and address line	C an..35	O	
3124 Name and address line	C an..35	O	
C080 Party name	C	O	
3036 Party name	M an..35	M	
3036 Party name	C an..35	O	
3036 Party name	C an..35	O	
3036 Party name	C an..35	O	
3036 Party name	C an..35	O	
3045 Party name format, coded	C an..3	O	
C059 Street	C	O	
3042 Street and number/p.o. box	M an..35	M	
3042 Street and number/p.o. box	C an..35	O	
3042 Street and number/p.o. box	C an..35	O	
3042 Street and number/p.o. box	C an..35	O	
3164 City name	C an..35	O	
3229 Country sub-entity identification	C an..9	O	
3251 Postcode identification	C an..9	O	
3207 Country, coded	C an..3	O	ISO 3166 two alpha country code.

SG4 - 9999 LIN-DTM-RFF-BUS-FCA-SG5-SG6-SG7-SG8-SG9-SG10-SG11			
SG9 - 10 GIS-MOA-LOC-NAD-RCS-FTX			
RCS - 1 Requirements and conditions			
UN/EDIFACT Directory 96.A C		D6 O	
A segment giving the nature (e.g. goods, transport services) and direction of each transaction to be reported in coded form.		The contents of this segment are to be determined nationally due to cross-border regulatory reporting or central bank requirements.	
CRG N			
Not used			
Segment number : 36			
UN/EDIFACT Directory 96.A		D6 Description	
CRG Description			
7293	Sector/subject identification qualifier	M an..3	M
C550	Requirement/condition identification	C	O
7295	Requirement/condition identification	M an..17	M
1131	Code list qualifier	C an..3	O
3055	Code list responsible agency, coded	C an..3	O
7294	Requirement or condition	C an..35	O
1229	Action request/notification, coded	C an..3	O

SG4 - 9999 LIN-DTM-RFF-BUS-FCA-SG5-SG6-SG7-SG8-SG9-SG10-SG11			
SG9 - 10 GIS-MOA-LOC-NAD-RCS-FTX			
FTX - 10 Free text			
UN/EDIFACT Directory 96.A C		D6 O	
A segment giving information in coded or in clear form to provide information relevant to regulatory authorities requirements.		The contents of this segment are to be determined nationally due to cross-border regulatory reporting or central bank requirements.	
CRG N			
Not used			
Segment number : 37			
UN/EDIFACT Directory 96.A		D6 Description	
		CRG Description	
4451	Text subject qualifier	M an..3	M
4453	Text function, coded	C an..3	O
C107	Text reference	C	O
4441	Free text, coded	M an..3	M
1131	Code list qualifier	C an..3	O
3055	Code list responsible agency, coded	C an..3	O
C108	Text literal	C	O
4440	Free text	M an..70	M
4440	Free text	C an..70	O
4440	Free text	C an..70	O
4440	Free text	C an..70	O
4440	Free text	C an..70	O
3453	Language, coded	C an..3	O

SG4 - 9999 LIN-DTM-RFF-BUS-FCA-SG5-SG6-SG7-SG8-SG9-SG10-SG11			
SG10 - 1 PRC-FTX			
UN/EDIFACT Directory 96.A C		D6 D	
A group of segments giving information in free form about the purpose of the direct debit from the creditor to the debtors.		The content of details of payment will be passed on to the debtor and will be added to each item contained in level C. It is recommended that PRC segment group be used in level-C for this purpose. This group is mutually exclusive with the PRC group in level C.	
UN/EDIFACT Directory 96.A C		CRG N	
A group of segments giving information in free form about the purpose of the direct debit from the creditor to the debtors.			
PRC - 1 Process identification			
UN/EDIFACT Directory 96.A M		D6 M	
A segment identifying the kind of process at the debtor's side.		This segment is also used as a trigger segment for group 10.	
UN/EDIFACT Directory 96.A		CRG N	
Segment number : 38			
UN/EDIFACT Directory 96.A		D6 Description	
UN/EDIFACT Directory 96.A		CRG Description	
C242 Process type and description	M	M	
7187 Process type identification	M an..17	M *R	11 = Processing of unstructured information - only the FTX segment must follow.
1131 Code list qualifier	C an..3	N	
3055 Code list responsible agency, coded	C an..3	N	
7186 Process type	C an..35	N	
7186 Process type	C an..35	N	
<u>Example:</u>			
PRC+11'			

SG4 - 9999 LIN-DTM-RFF-BUS-FCA-SG5-SG6-SG7-SG8-SG9-SG10-SG11					
SG10 - 1 PRC-FTX					
FTX - 1 Free text					
UN/EDIFACT Directory 96.A M			D6 M		CRG N
A segment providing clear form information from the creditor to the debtor.			Specification of details of payment in free form, from the beneficiary to the debtor. This information is applicable to all subsequent transactions in the C-levels.		Not used
Segment number : 39					
UN/EDIFACT Directory 96.A			D6 Description		CRG Description
4451	Text subject qualifier	M an..3	M	*R	PMD = Payment detail/remittance information
4453	Text function, coded	C an..3	N		
C107	Text reference	C	N		
4441	Free text, coded	M an..3			
1131	Code list qualifier	C an..3			
3055	Code list responsible agency, coded	C an..3			
C108	Text literal	C	R		
4440	Free text	M an..70	M		
4440	Free text	C an..70	O		
4440	Free text	C an..70	O		
4440	Free text	C an..70	O		
4440	Free text	C an..70	O		
3453	Language, coded	C an..3	O		
<u>Example:</u>					
FTX+PMD+++EMBARGO PAYMENT RESTRICTIONS IN FORCE+EN'					

SG4 - 9999 LIN-DTM-RFF-BUS-FCA-SG5-SG6-SG7-SG8-SG9-SG10-SG11			
SG11 - 9999 SEQ-MOA-DTM-RFF-PAI-FCA-SG12-SG13-SG14-SG15-SG16			
UN/EDIFACT Directory 96.A M		D6 M	
This Segment Group contains information regarding the debtor(s) of the direct debit. Certain payment details may be provided either in Segment Group 11 or in Segment Group 4, but not in both.		This segment group contains information about the individual direct debits within this B-level of the message. Certain payment details may be provided either in segment group 4 or in segment group 11, but not in both. Please refer to the segment group description of SG4	
SEQ - 1 Sequence details			
UN/EDIFACT Directory 96.A M		D6 M	
A segment identifying the beginning of the debit side of the transaction (C level) by a sequential number, which may also be used for reconciliation purposes.		This is a trigger segment specifying the start of each single transaction.	
Segment number : 40			
UN/EDIFACT Directory 96.A		D6 Description	
1245 Status indicator, coded C286 Sequence information 1050 Sequence number 1159 Sequence number source, coded 1131 Code list qualifier 3055 Code list responsible agency, coded		Application generated number of the count of the sequence in a direct debit. The sequence number must be reset to one for each occurrence of a new line number (in LIN segment).	
C an..3	N		
C	R		
M an..6	M		
C an..3	N		
C an..3	N		
C an..3	N		
<u>Example:</u>			
SEQ++1'			

SG4 - 9999 LIN-DTM-RFF-BUS-FCA-SG5-SG6-SG7-SG8-SG9-SG10-SG11						
SG11 - 9999 SEQ-MOA-DTM-RFF-PAI-FCA-SG12-SG13-SG14-SG15-SG16						
MOA - 1 Monetary amount						
UN/EDIFACT Directory 96.A M			D6 M		CRG M	
A segment giving the amount of the direct debit. It is the amount to be collected. The currency is quoted on the credit side of the transaction (B level).			A segment identifying the amount of the direct debit. If it is an equivalent amount the direct debit currency is quoted in the CUX segment on B-level.			
Segment number : 41						
UN/EDIFACT Directory 96.A			D6 Description		CRG Description	
C516 Monetary amount	M	M		<p>9 = Amount due/amount payable 57 = Equivalent amount</p> <p>The codes used in levels B and C must be identical; a mixture of codes 9 and 57 is not permitted.</p> <p>The decimal separator is either a comma or a dot. No other delimiters, e.g., thousands separators, are allowed.</p> <p>ISO 4217 currency code.</p> <p>This data element is mandatory if code 9 (amount due/amount payable) is used in DE 5025 and must be identical to the currency quoted in DE 6345 of the MOA segment in segment group 5 (on B-level).</p> <p>This data element is not used if code 57 (equivalent amount) is used in DE 5025, the currency having been specified as the reference currency in segment group 5 (on B-level).</p>	Only use code 9	
5025 Monetary amount type qualifier	M an..3	M	* *			
5004 Monetary amount	C n..18	R				
6345 Currency, coded	C an..3	D				
6343 Currency qualifier	C an..3	N				
4405 Status, coded	C an..3	N				
Example:						
MOA+9:430000:EUR'						

SG4 - 9999 LIN-DTM-RFF-BUS-FCA-SG5-SG6-SG7-SG8-SG9-SG10-SG11						
SG11 - 9999 SEQ-MOA-DTM-RFF-PAI-FCA-SG12-SG13-SG14-SG15-SG16						
DTM - 1 Date/time/period						
UN/EDIFACT Directory 96.A C			D6 O		CRG O	
A segment identifying date(s)/time(s) to the debtor's side.			Usage due to national law and practice.			
Segment number : 42						
UN/EDIFACT Directory 96.A			D6 Description		CRG Description	
C507 Date/time/period	M	M	M	*	434 = Maturity date 448 = Referenced item creation date 749 = Period between issue date and maturity date (D6 code) Codes 434 and 448 are mutually exclusive.	Only use code 434
2005 Date/time/period qualifier	M an..3	M		*		
				*		
2380 Date/time/period	C an..35	R	R	*	102 = CCYYMMDD 203 = CCYYMMDDHHMM 711 = CCYYMMDD – CCYYMMDD (only allowed with code 749 in DE 2005).	Only use code 102
2379 Date/time/period format qualifier	C an..3	R		*		
				*		
<u>Example:</u>						
DTM+749:20000126:102'						

SG4 - 9999 LIN-DTM-RFF-BUS-FCA-SG5-SG6-SG7-SG8-SG9-SG10-SG11			
SG11 - 9999 SEQ-MOA-DTM-RFF-PAI-FCA-SG12-SG13-SG14-SG15-SG16			
RFF - 3 Reference			
UN/EDIFACT Directory 96.A C		D6 R	
A segment identifying a transaction from the creditor to the debtor and/or from the creditor to the creditor's bank.		A segment identifying the reference number of this transaction between the beneficiary and the beneficiary's bank. The segment can furthermore identify payment references between the beneficiary and the debtor.	
Segment number : 43			
UN/EDIFACT Directory 96.A		D6 Description	
C506 Reference		M	
1153 Reference qualifier	M an..3	M	R
		M	
			CR = Customer reference number - this mandatory reference number is used for reconciliation between the ordering customer and its bank. RA = Remittance advice number- the reference number of a separately sent message, a remittance advice, which contains the details of payment PQ = Payment reference - this customer to customer reference is not the remittance advice number. Codes RA and PQ are mutually exclusive and are passed through the banking chain. AGB = Contract party reference number (direct debit mandate number). The usage of this code is subject to national agreement.
1154 Reference number	C an..35	R	
1156 Line number	C an..6	N	
4000 Reference version number	C an..35	N	
<u>Example:</u>			
RFF+CR:43155836'			

SG4 - 9999 LIN-DTM-RFF-BUS-FCA-SG5-SG6-SG7-SG8-SG9-SG10-SG11			
SG11 - 9999 SEQ-MOA-DTM-RFF-PAI-FCA-SG12-SG13-SG14-SG15-SG16			
PAI - 1 Payment instructions			
UN/EDIFACT Directory 96.A C		D6 O	
A segment specifying the conditions, method and channel of payment for the direct debit.		This segment must be used according to bilaterally agreed domestic standards only.	
CRG N			
Segment number : 44			
UN/EDIFACT Directory 96.A		D6 Description	
CRG Description			
C534	Payment instruction details	M	M
4439	Payment conditions, coded	C an..3	O
4431	Payment guarantee, coded	C an..3	O
4461	Payment means, coded	C an..3	O
1131	Code list qualifier	C an..3	O
3055	Code list responsible agency, coded	C an..3	O
4435	Payment channel, coded	C an..3	O
Method of payment and payment channel.			
<u>Example:</u>			
PAI+::31::5'			

SG4 - 9999 LIN-DTM-RFF-BUS-FCA-SG5-SG6-SG7-SG8-SG9-SG10-SG11						
SG11 - 9999 SEQ-MOA-DTM-RFF-PAI-FCA-SG12-SG13-SG14-SG15-SG16						
FCA - 1 Financial charges allocation						
UN/EDIFACT Directory 96.A C		D6 D			CRG D	
A segment specifying the method for allocation of charges and allowances and identifying the creditor's account to which such charges or allowances should be directed where it is different from the principal account. This segment is mutually exclusive with the FCA segment in Segment Group 4.		This segment is mutually exclusive with the FCA segment in level B.				
Segment number : 45						
UN/EDIFACT Directory 96.A		D6 Description			CRG Description	
4471 Settlement, coded	M an..3	M	*	13 = All charges borne by payee - or creditor	M	
			*	14 = Each pay own cost		
			*	15 = All charges borne by payor - or debtor		
C878 Charge/allowance account	C	O		The usage of this composite is subject to bilateral agreement	N	Composite DE not used
3434 Institution branch number	M an..17	M		National identification of the financial institution in coded form	N	Not used
1131 Code list qualifier	C an..3	R	*	The allowed combinations of the codes of DE1131 and 3055 are stated in Section 1.5. of this MIG.	N	Not used
3055 Code list responsible agency, coded	C an..3	R	*	The allowed combinations of the codes of DE1131 and 3055 are stated in Section 1.5. of this MIG.	N	Not used
3194 Account holder number	C an..35	R			N	Not used
6345 Currency, coded	C an..3	O		ISO 4217 three alpha currency code	N	Not used
<u>Example:</u> FCA+15'						

SG4 - 9999 LIN-DTM-RFF-BUS-FCA-SG5-SG6-SG7-SG8-SG9-SG10-SG11						
SG11 - 9999 SEQ-MOA-DTM-RFF-PAI-FCA-SG12-SG13-SG14-SG15-SG16						
SG12 - 3 FII-CTA-COM						
UN/EDIFACT Directory 96.A C		D6 R				
A group of segments containing the debtor's bank and the account and if necessary up to two intermediary banks.		A group of segments containing the Payer's financial institution including the account to be debited.				
FII - 1 Financial institution information						
UN/EDIFACT Directory 96.A M		D6 M				
A segment identifying the financial institution and relevant account number associated with the transaction, and their functions.		This segment identifies the financial institution and account of the debtor involved in the individual direct debit transaction				
Bank account definition varies with countries as it sometimes includes the national bank/branching sorting code and sometimes not, often leading to errors. The correct implementation is to have one single string. However for the time being it can be split if agreed nationally. Please also refer to CRG document with examples (available at http://www1.stuzza.at/crg/migs/fii-seg.doc)..						
Segment number : 46						
UN/EDIFACT Directory 96.A		D6 Description				
CRG Description						
3035 Party qualifier	M an..3	M	*R	PH = Payer's financial institution		
C078 Account identification	C	R				
3194 Account holder number	C an..35	R		The account number should be entered according to the national account number scheme. In certain national circumstances this will be an identification which leads to the account information. If an IBAN is used, it should be present in this DE. Identifying the name and place of the account holder is mandatory in some countries. For more information about dependencies, refer to Section 1.4. of this MIG.		
3192 Account holder name	C an..35	D				
3192 Account holder name	C an..35	O				
6345 Currency, coded	C an..3	O		ISO 4217 three alpha currency code		

C088 Institution identification	C	D		This composite DE is not needed in some countries. BIC codes are to be mapped into 3433 and national codes in 3434. They should not be mutually exclusive, but the following priority rule should be followed: 1. IBAN in 3194. 2a. For domestic payments: Bank account no. in 3194 and national bank identification in 3434 / 1131 / 3055. 2b. For international payments: Bank account no. in 3194 and international bank identification (BIC) in 3433 / 1131 /3055. 3a. For domestic payments: Bank account no. in 3194 and international bank identification (BIC) in 3433 / 1131 / 3055. 3b. For international payments: Bank account no. in 3194 and national bank identification in 3434 / 1131 / 3055. In case of contradiction the definiton with highest priority will be used.	
3433 Institution name identification	C an..11	D		International identification of the financial institution in coded form.	
1131 Code list qualifier	C an..3	D	*R	25 = Bank identification	
3055 Code list responsible agency, coded	C an..3	D	*R	5 = ISO (International Organization for Standardization)	
3434 Institution branch number	C an..17	D		National identification of the financial institution in coded form	
1131 Code list qualifier	C an..3	D	*	The allowed combinations of the codes of DE1131 and 3055 are stated in Section 1.5. of this MIG.	
3055 Code list responsible agency, coded	C an..3	D	*	The allowed combinations of the codes of DE1131 and 3055 are stated in Section 1.5. of this MIG.	
3432 Institution name	C an..70	N			
3436 Institution branch place	C an..70	N			
3207 Country, coded	C an..3	D		ISO 3166 two alpha country code. This data element should be used unless an IBAN is included in DE3194.	
Example: FII+PH+348316143405:BENETTON:MILANO+BNLIITMM:25:5+IT'					

SG4 - 9999 LIN-DTM-RFF-BUS-FCA-SG5-SG6-SG7-SG8-SG9-SG10-SG11			
SG11 - 9999 SEQ-MOA-DTM-RFF-PAI-FCA-SG12-SG13-SG14-SG15-SG16			
SG12 - 3 FII-CTA-COM			
CTA - 1 Contact information			
UN/EDIFACT Directory 96.A C		D6 N	
A segment identifying a person or a department for the party specified in the leading FII segment to whom communication should be directed.		CRG N	
Segment number : 47			
UN/EDIFACT Directory 96.A		D6 Description	
CRG Description			
3139 Contact function, coded	C an..3		
C056 Department or employee details	C		
3413 Department or employee identification	C an..17		
3412 Department or employee	C an..35		

SG4 - 9999 LIN-DTM-RFF-BUS-FCA-SG5-SG6-SG7-SG8-SG9-SG10-SG11			
SG11 - 9999 SEQ-MOA-DTM-RFF-PAI-FCA-SG12-SG13-SG14-SG15-SG16			
SG12 - 3 FII-CTA-COM			
COM - 5 Communication contact			
UN/EDIFACT Directory 96.A C		D6 N	
UN/EDIFACT Directory 96.A		CRG N	
A segment identifying communication type(s) and number(s) of person(s) or department(s) specified in the associated CTA segment.			
Segment number : 48			
UN/EDIFACT Directory 96.A		D6 Description	
UN/EDIFACT Directory 96.A		CRG Description	
C076	Communication contact	M	
3148	Communication number	M an..512	
3155	Communication channel qualifier	M an..3	

3124	Name and address line	C an..35	O		
3124	Name and address line	C an..35	O		
C080	Party name	C	D	Either C058 or DE's C080, C059, 3164, 3229, 3251 and 3207 are used.	
3036	Party name	M an..35	M		
3036	Party name	C an..35	O		
3036	Party name	C an..35	O		
3036	Party name	C an..35	O		
3036	Party name	C an..35	O		
3045	Party name format, coded	C an..3	O		
C059	Street	C	D		
3042	Street and number/p.o. box	M an..35	M		
3042	Street and number/p.o. box	C an..35	O		
3042	Street and number/p.o. box	C an..35	O		
3042	Street and number/p.o. box	C an..35	O		
3164	City name	C an..35	D		
3229	Country sub-entity identification	C an..9	D		
3251	Postcode identification	C an..9	D		
3207	Country, coded	C an..3	D	Country of the identified party, in ISO 3166 coded form. ISO 3166 two alpha country code.	
<u>Example:</u>					
NAD+PE+++BENETTON++MILANO+++IT'					

SG4 - 9999 LIN-DTM-RFF-BUS-FCA-SG5-SG6-SG7-SG8-SG9-SG10-SG11				
SG11 - 9999 SEQ-MOA-DTM-RFF-PAI-FCA-SG12-SG13-SG14-SG15-SG16				
SG13 - 3 NAD-CTA-COM				
CTA - 1 Contact information				
UN/EDIFACT Directory 96.A C		D6 O		CRG O
A segment identifying a person or a department for the party specified in the leading NAD segment to whom communication should be directed.				
Segment number : 50				
UN/EDIFACT Directory 96.A		D6 Description		CRG Description
3139 Contact function, coded	C an..3	R	*R	IC = Information contact
C056 Department or employee details	C	R		
3413 Department or employee identification	C an..17	N		
3412 Department or employee	C an..35	R		Name of the department or the employee in free text form.
<u>Example:</u>				
CTA+IC+: HELGA SCHMIDT'				

SG4 - 9999 LIN-DTM-RFF-BUS-FCA-SG5-SG6-SG7-SG8-SG9-SG10-SG11					
SG11 - 9999 SEQ-MOA-DTM-RFF-PAI-FCA-SG12-SG13-SG14-SG15-SG16					
SG13 - 3 NAD-CTA-COM					
COM - 5 Communication contact					
UN/EDIFACT Directory 96.A C			D6 O		CRG O
A segment identifying communication type(s) and number(s) of person(s) or department(s) specified in the associated CTA segment.					
Segment number : 51					
UN/EDIFACT Directory 96.A			D6 Description		CRG Description
C076	Communication contact	M	M		
3148	Communication number	M an..512	M		When character sets UNOA or UNOB are used, the @ in e-mail addresses must be shown with (at) (parenthesis, at, parenthesis), e.g. <john.smith(at)abc.com>.
3155	Communication channel qualifier	M an..3	M		
<u>Example:</u>					
COM+12127783894:TE'					

SG4 - 9999 LIN-DTM-RFF-BUS-FCA-SG5-SG6-SG7-SG8-SG9-SG10-SG11			
SG11 - 9999 SEQ-MOA-DTM-RFF-PAI-FCA-SG12-SG13-SG14-SG15-SG16			
SG14 - 3 INP-FTX-DTM			
UN/EDIFACT Directory 96.A C	D6	O	CRG N
A group of segments containing instructions from the creditor relating to parties identified in the NAD and FII segments. It specifies action to be taken by the identified parties, and the date (and optionally time) by which such actions needs to be taken.			Not used
INP - 1 Parties to instruction			
UN/EDIFACT Directory 96.A M	D6	M	CRG N
A segment identifying the party to enact the instruction and the parties to be contacted. It specifies where appropriate the instruction in coded form.			Not used
Segment number : 52			
UN/EDIFACT Directory 96.A	D6 Description		CRG Description
C849 Parties to instruction	C	R	
3301 Party enacting instruction identification	M an..17	M	* 8 = Debtor's bank * 3 = beneficiary's bank
3285 Recipient of the instruction identification	C an..17	D	*R 15 = Debtor Use of code 15 depends on the instruction.
C522 Instruction	C	D	The instruction must be found in this composite or in the following FTX segment. The use of the FTX will prevent automated processing of the message.
4403 Instruction qualifier	M an..3	M	*R 2 = Party instructions
4401 Instruction, coded	C an..3	R	
1131 Code list qualifier	C an..3	N	
3055 Code list responsible agency, coded	C an..3	N	
4400 Instruction	C an..35	N	
C850 Status of instruction	C	N	
4405 Status, coded	M an..3		
3036 Party name	C an..35		
1229 Action request/notification, coded	C an..3	N	
<u>Example:</u> INP+8+YW8:AD'			

SG4 - 9999 LIN-DTM-RFF-BUS-FCA-SG5-SG6-SG7-SG8-SG9-SG10-SG11			
SG11 - 9999 SEQ-MOA-DTM-RFF-PAI-FCA-SG12-SG13-SG14-SG15-SG16			
SG14 - 3 INP-FTX-DTM			
FTX - 1 Free text			
UN/EDIFACT Directory 96.A C		D6 D	
A segment providing free text instruction relating to the associated INP segment.		The instruction must be found in this segment or in the preceding INP DE C522:4401 . The use of this segment will prevent automated processing of the message.	
CRG N			
Not used			
Segment number : 53			
UN/EDIFACT Directory 96.A		D6 Description	
CRG Description			
4451	Text subject qualifier	M an..3	M *R
4453	Text function, coded	C an..3	N
C107	Text reference	C	N
4441	Free text, coded	M an..3	
1131	Code list qualifier	C an..3	
3055	Code list responsible agency, coded	C an..3	
C108	Text literal	C	R
4440	Free text	M an..70	M
4440	Free text	C an..70	O
4440	Free text	C an..70	O
4440	Free text	C an..70	O
4440	Free text	C an..70	O
3453	Language, coded	C an..3	O
<u>Example:</u>			
FTX+AAG+++EMBARGO REGULATIONS+EN'			

SG4 - 9999 LIN-DTM-RFF-BUS-FCA-SG5-SG6-SG7-SG8-SG9-SG10-SG11					
SG11 - 9999 SEQ-MOA-DTM-RFF-PAI-FCA-SG12-SG13-SG14-SG15-SG16					
SG14 - 3 INP-FTX-DTM					
DTM - 2 Date/time/period					
UN/EDIFACT Directory 96.A C			D6 O		CRG N
A segment specifying the earliest and latest dates and/or times by which the instruction specified in the INP and/or FTX segment(s) needs to be carried out.					Not used
Segment number : 54					
UN/EDIFACT Directory 96.A			D6 Description		CRG Description
C507 Date/time/period	M	M			
2005 Date/time/period qualifier	M an..3	M	*	174 = Advise after date/time	
			*	175 = Advise before date/time	
			*	176 = Advise completed date/time	
			*	177 = Advise on date/time	
2380 Date/time/period	C an..35	R			
2379 Date/time/period format qualifier	C an..3	R	*	102 = CCYYMMDD	
			*	203 = CCYYMMDDHHMM	
<u>Example:</u>					
DTM+175:200001261500:102'					

SG4 - 9999 LIN-DTM-RFF-BUS-FCA-SG5-SG6-SG7-SG8-SG9-SG10-SG11			
SG11 - 9999 SEQ-MOA-DTM-RFF-PAI-FCA-SG12-SG13-SG14-SG15-SG16			
SG15 - 10 GIS-MOA-LOC-NAD-RCS-FTX			
UN/EDIFACT Directory 96.A C		D6 O	
A group of segments providing information for subsequent use by regulatory authorities requiring statistical and other types of data. It also identifies the regulatory authority for which the information is intended followed by the information itself.		The specifications of this segment group are to be determined on unilateral regulatory reporting requirements.	
GIS - 1 General indicator			
UN/EDIFACT Directory 96.A M		D6 M	
A segment identifying what processing should be completed for regulatory authorities.		The contents of this segment are to be determined nationally due to cross-border regulatory reporting or central bank requirements .	
Segment number : 55			
UN/EDIFACT Directory 96.A		D6 Description	
C529 Processing indicator 7365 Processing indicator, coded 1131 Code list qualifier 3055 Code list responsible agency, coded 7187 Process type identification		M M an..3 C an..3 C an..3 C an..17	M M O O O
		CRG Description	

SG4 - 9999 LIN-DTM-RFF-BUS-FCA-SG5-SG6-SG7-SG8-SG9-SG10-SG11			
SG11 - 9999 SEQ-MOA-DTM-RFF-PAI-FCA-SG12-SG13-SG14-SG15-SG16			
SG15 - 10 GIS-MOA-LOC-NAD-RCS-FTX			
MOA - 1 Monetary amount			
UN/EDIFACT Directory 96.A C		D6 O	
A segment giving the amount and the currency of each transaction to be reported.		The contents of this segment are to be determined nationally due to cross-border regulatory reporting or central bank requirements .	
Segment number : 56			
UN/EDIFACT Directory 96.A		D6 Description	
UN/EDIFACT Directory 96.A		CRG Description	
C516 Monetary amount	M	M	
5025 Monetary amount type qualifier	M an..3	M	
5004 Monetary amount	C n..18	O	
6345 Currency, coded	C an..3	O	
6343 Currency qualifier	C an..3	O	
4405 Status, coded	C an..3	O	

SG4 - 9999 LIN-DTM-RFF-BUS-FCA-SG5-SG6-SG7-SG8-SG9-SG10-SG11			
SG11 - 9999 SEQ-MOA-DTM-RFF-PAI-FCA-SG12-SG13-SG14-SG15-SG16			
SG15 - 10 GIS-MOA-LOC-NAD-RCS-FTX			
LOC - 2 Place/location identification			
UN/EDIFACT Directory 96.A C		D6 O	
A segment giving the different origins/destinations (places) of goods/ investment/services.		The contents of this segment are to be determined nationally due to cross-border regulatory reporting or central bank requirements .	
Segment number : 57			
UN/EDIFACT Directory 96.A		D6 Description	
		CRG Description	
3227	Place/location qualifier	M an..3	M
C517	Location identification	C	O
3225	Place/location identification	C an..25	O
1131	Code list qualifier	C an..3	O
3055	Code list responsible agency, coded	C an..3	O
3224	Place/location	C an..70	O
C519	Related location one identification	C	O
3223	Related place/location one identification	C an..25	O
1131	Code list qualifier	C an..3	O
3055	Code list responsible agency, coded	C an..3	O
3222	Related place/location one	C an..70	O
C553	Related location two identification	C	O
3233	Related place/location two identification	C an..25	O
1131	Code list qualifier	C an..3	O
3055	Code list responsible agency, coded	C an..3	O
3232	Related place/location two	C an..70	O
5479	Relation, coded	C an..3	O

SG4 - 9999 LIN-DTM-RFF-BUS-FCA-SG5-SG6-SG7-SG8-SG9-SG10-SG11			
SG11 - 9999 SEQ-MOA-DTM-RFF-PAI-FCA-SG12-SG13-SG14-SG15-SG16			
SG15 - 10 GIS-MOA-LOC-NAD-RCS-FTX			
NAD - 1 Name and address			
UN/EDIFACT Directory 96.A C		D6 O	
A segment identifying a party related to the associated informative text.		The contents of this segment are to be determined nationally due to cross-border regulatory reporting or central bank requirements .	
Segment number : 58			
UN/EDIFACT Directory 96.A		D6 Description	
		CRG Description	
3035 Party qualifier	M an..3	M	
C082 Party identification details	C	O	
3039 Party id. identification	M an..35	M	
1131 Code list qualifier	C an..3	O	
3055 Code list responsible agency, coded	C an..3	O	
C058 Name and address	C	O	
3124 Name and address line	M an..35	M	
3124 Name and address line	C an..35	O	
3124 Name and address line	C an..35	O	
3124 Name and address line	C an..35	O	
3124 Name and address line	C an..35	O	
C080 Party name	C	O	
3036 Party name	M an..35	M	
3036 Party name	C an..35	O	
3036 Party name	C an..35	O	
3036 Party name	C an..35	O	
3036 Party name	C an..35	O	
3045 Party name format, coded	C an..3	O	
C059 Street	C	O	
3042 Street and number/p.o. box	M an..35	M	
3042 Street and number/p.o. box	C an..35	O	
3042 Street and number/p.o. box	C an..35	O	
3042 Street and number/p.o. box	C an..35	O	
3164 City name	C an..35	O	
3229 Country sub-entity identification	C an..9	O	
3251 Postcode identification	C an..9	O	
3207 Country, coded	C an..3	O	ISO 3166 two alpha country code.

SG4 - 9999 LIN-DTM-RFF-BUS-FCA-SG5-SG6-SG7-SG8-SG9-SG10-SG11			
SG11 - 9999 SEQ-MOA-DTM-RFF-PAI-FCA-SG12-SG13-SG14-SG15-SG16			
SG15 - 10 GIS-MOA-LOC-NAD-RCS-FTX			
RCS - 1 Requirements and conditions			
UN/EDIFACT Directory 96.A C		D6 O	
A segment giving the nature (e.g. goods, transport services) and direction of each transaction to be reported in coded form.		The contents of this segment are to be determined nationally due to cross-border regulatory reporting or central bank requirements .	
Segment number : 59			
UN/EDIFACT Directory 96.A		D6 Description	
7293 Sector/subject identification qualifier	M an..3	M	
C550 Requirement/condition identification	C	O	
7295 Requirement/condition identification	M an..17	M	
1131 Code list qualifier	C an..3	O	
3055 Code list responsible agency, coded	C an..3	O	
7294 Requirement or condition	C an..35	O	
1229 Action request/notification, coded	C an..3	O	
UN/EDIFACT Directory 96.A		CRG Description	

SG4 - 9999 LIN-DTM-RFF-BUS-FCA-SG5-SG6-SG7-SG8-SG9-SG10-SG11			
SG11 - 9999 SEQ-MOA-DTM-RFF-PAI-FCA-SG12-SG13-SG14-SG15-SG16			
SG15 - 10 GIS-MOA-LOC-NAD-RCS-FTX			
FTX - 10 Free text			
UN/EDIFACT Directory 96.A C		D6 O	
A segment giving information in coded or in clear form to provide information relevant to regulatory authorities requirements.		The contents of this segment are to be determined nationally due to cross-border regulatory reporting or central bank requirements .	
Segment number : 60			
UN/EDIFACT Directory 96.A		D6 Description	
		CRG Description	
4451	Text subject qualifier	M an..3	M
4453	Text function, coded	C an..3	O
C107	Text reference	C	O
4441	Free text, coded	M an..3	M
1131	Code list qualifier	C an..3	O
3055	Code list responsible agency, coded	C an..3	O
C108	Text literal	C	O
4440	Free text	M an..70	M
4440	Free text	C an..70	O
4440	Free text	C an..70	O
4440	Free text	C an..70	O
4440	Free text	C an..70	O
3453	Language, coded	C an..3	O

SG4 - 9999 LIN-DTM-RFF-BUS-FCA-SG5-SG6-SG7-SG8-SG9-SG10-SG11			
SG11 - 9999 SEQ-MOA-DTM-RFF-PAI-FCA-SG12-SG13-SG14-SG15-SG16			
SG16 - 1 PRC-FTX-SG17-SG23			
UN/EDIFACT Directory 96.A C		D6 D	
A group of segments containing the details of the direct debit. The content of these segments is passed through the banking chain from the creditor to the debtor.		The content of details of payment will be passed on to the debtor. This group is mutually exclusive with the PRC group in Level B.	
PRC - 1 Process identification			
UN/EDIFACT Directory 96.A M		D6 M	
A segment identifying the kind of processing at the debtor's side.		This segment is also used as a trigger segment for group 16.	
Segment number : 61			
UN/EDIFACT Directory 96.A		D6 Description	
C242 Process type and description			
7187 Process type identification	M M an..17	M M	* * * *
1131 Code list qualifier	C an..3	N	
3055 Code list responsible agency, coded	C an..3	N	
7186 Process type	C an..35	N	
7186 Process type	C an..35	N	
<u>Example:</u>			
PRC+11'			

SG4 - 9999 LIN-DTM-RFF-BUS-FCA-SG5-SG6-SG7-SG8-SG9-SG10-SG11						
SG11 - 9999 SEQ-MOA-DTM-RFF-PAI-FCA-SG12-SG13-SG14-SG15-SG16						
SG16 - 1 PRC-FTX-SG17-SG23						
FTX - 5 Free text						
UN/EDIFACT Directory 96.A C			D6 D		CRG D	
A segment providing free text instruction(s) relating to the direct debit details.						
Segment number : 62						
UN/EDIFACT Directory 96.A			D6 Description		CRG Description	
4451	Text subject qualifier	M an..3	M	*R	PMD = Payment detail/remittance information	
4453	Text function, coded	C an..3	N			
C107	Text reference	C	N			
4441	Free text, coded	M an..3				
1131	Code list qualifier	C an..3				
3055	Code list responsible agency, coded	C an..3				
C108	Text literal	C	R			
4440	Free text	M an..70	M			
4440	Free text	C an..70	O			
4440	Free text	C an..70	O			
4440	Free text	C an..70	O			
4440	Free text	C an..70	O			
3453	Language, coded	C an..3	O			
<u>Example:</u>						
FTX+PMD+++LIMITED LIABILITY+EN'						

SG4 - 9999 LIN-DTM-RFF-BUS-FCA-SG5-SG6-SG7-SG8-SG9-SG10-SG11			
SG11 - 9999 SEQ-MOA-DTM-RFF-PAI-FCA-SG12-SG13-SG14-SG15-SG16			
SG16 - 1 PRC-FTX-SG17-SG23			
SG17 - 9999 DOC-MOA-DTM-RFF-NAD-SG18-SG19-SG20			
UN/EDIFACT Directory 96.A C		D6 D	
A group of segments providing details of all documents e.g., invoices, statements, despatch advices, etc., to which the direct debit refers. It includes information on the monetary amounts for each document and on any adjustments (with an indication of the reason for adjustments) and discounts. For information purposes an indication of the tax element can be provided.		The contents of this segment group (segment group 17 to 23) are specified by the trading partners' requirements. The user handbook issuer is not liable for the content and usage of details of payment specified in this segment group. The usage of codes in this segment group should be in line with those of the customer-to-customer remittance advice.	
DOC - 1 Document/message details			
UN/EDIFACT Directory 96.A M		D6 M	
A segment identifying the reference document against which payment is being made.		The contents of this segment are specified by trading partners' requirements. The usage of codes in this segment should be in line with those of the customer-to-customer remittance advice.	
Segment number : 63			
UN/EDIFACT Directory 96.A		D6 Description	
CRG Description			
C002 Document/message name	M	M	
1001 Document/message name, coded	C an..3	O	
1131 Code list qualifier	C an..3	O	
3055 Code list responsible agency, coded	C an..3	O	
1000 Document/message name	C an..35	O	
C503 Document/message details	C	O	
1004 Document/message number	C an..35	O	
1373 Document/message status, coded	C an..3	O	
1366 Document/message source	C an..35	O	
3453 Language, coded	C an..3	O	
3153 Communication channel identifier, coded	C an..3	O	
1220 Number of copies of document required	C n..2	O	
1218 Number of originals of document required	C n..2	O	

SG4 - 9999 LIN-DTM-RFF-BUS-FCA-SG5-SG6-SG7-SG8-SG9-SG10-SG11			
SG11 - 9999 SEQ-MOA-DTM-RFF-PAI-FCA-SG12-SG13-SG14-SG15-SG16			
SG16 - 1 PRC-FTX-SG17-SG23			
SG17 - 9999 DOC-MOA-DTM-RFF-NAD-SG18-SG19-SG20			
MOA - 5 Monetary amount			
UN/EDIFACT Directory 96.A C		D6 O	
A segment giving the monetary amounts of each reference document (e.g., original amount, discount amount etc.). The amount due and the amount remitted are mandatory.		The contents of this segment are specified by trading partners' requirements. The usage of codes in this segment should be in line with those of the customer-to-customer remittance advice.	
Segment number : 64			
UN/EDIFACT Directory 96.A		D6 Description	
C516 Monetary amount		CRG Description	
5025 Monetary amount type qualifier	M an..3	M	
5004 Monetary amount	C n..18	O	
6345 Currency, coded	C an..3	O	
6343 Currency qualifier	C an..3	O	
4405 Status, coded	C an..3	O	

SG4 - 9999 LIN-DTM-RFF-BUS-FCA-SG5-SG6-SG7-SG8-SG9-SG10-SG11			
SG11 - 9999 SEQ-MOA-DTM-RFF-PAI-FCA-SG12-SG13-SG14-SG15-SG16			
SG16 - 1 PRC-FTX-SG17-SG23			
SG17 - 9999 DOC-MOA-DTM-RFF-NAD-SG18-SG19-SG20			
DTM - 5 Date/time/period			
UN/EDIFACT Directory 96.A C		D6 O	
A segment specifying the date of the referenced document and indicating any other relevant dates applicable.		The contents of this segment are specified by trading partners' requirements. The usage of codes in this segment should be in line with those of the customer-to-customer remittance advice.	
Segment number : 65			
UN/EDIFACT Directory 96.A		D6 Description	
CRG Description			
C507 Date/time/period	M	M	
2005 Date/time/period qualifier	M an..3	M	
2380 Date/time/period	C an..35	O	
2379 Date/time/period format qualifier	C an..3	O	

SG4 - 9999 LIN-DTM-RFF-BUS-FCA-SG5-SG6-SG7-SG8-SG9-SG10-SG11			
SG11 - 9999 SEQ-MOA-DTM-RFF-PAI-FCA-SG12-SG13-SG14-SG15-SG16			
SG16 - 1 PRC-FTX-SG17-SG23			
SG17 - 9999 DOC-MOA-DTM-RFF-NAD-SG18-SG19-SG20			
RFF - 5 Reference			
UN/EDIFACT Directory 96.A C		D6 O	
A segment for the inclusion of any additional references related to the reference document.		The contents of this segment are specified by trading partners' requirements. The usage of codes in this segment should be in line with those of the customer-to-customer remittance advice.	
Segment number : 66			
UN/EDIFACT Directory 96.A		D6 Description	
UN/EDIFACT Directory 96.A		CRG Description	
C506 Reference	M	M	
1153 Reference qualifier	M an..3	M	
1154 Reference number	C an..35	O	
1156 Line number	C an..6	O	
4000 Reference version number	C an..35	O	

SG4 - 9999 LIN-DTM-RFF-BUS-FCA-SG5-SG6-SG7-SG8-SG9-SG10-SG11			
SG11 - 9999 SEQ-MOA-DTM-RFF-PAI-FCA-SG12-SG13-SG14-SG15-SG16			
SG16 - 1 PRC-FTX-SG17-SG23			
SG17 - 9999 DOC-MOA-DTM-RFF-NAD-SG18-SG19-SG20			
NAD - 2 Name and address			
UN/EDIFACT Directory 96.A C		D6 O	
A segment identifying a party name and address, either by coded identification or in a clear form.		The contents of this segment are specified by trading partners' requirements. The usage of codes in this segment should be in line with those of the customer-to-customer remittance advice.	
Segment number : 67			
UN/EDIFACT Directory 96.A		D6 Description	
		CRG Description	
3035 Party qualifier	M an..3	M	
C082 Party identification details	C	O	
3039 Party id. identification	M an..35	M	
1131 Code list qualifier	C an..3	O	
3055 Code list responsible agency, coded	C an..3	O	
C058 Name and address	C	O	
3124 Name and address line	M an..35	M	
3124 Name and address line	C an..35	O	
3124 Name and address line	C an..35	O	
3124 Name and address line	C an..35	O	
3124 Name and address line	C an..35	O	
C080 Party name	C	O	
3036 Party name	M an..35	M	
3036 Party name	C an..35	O	
3036 Party name	C an..35	O	
3036 Party name	C an..35	O	
3036 Party name	C an..35	O	
3045 Party name format, coded	C an..3	O	
C059 Street	C	O	
3042 Street and number/p.o. box	M an..35	M	
3042 Street and number/p.o. box	C an..35	O	
3042 Street and number/p.o. box	C an..35	O	
3042 Street and number/p.o. box	C an..35	O	
3164 City name	C an..35	O	
3229 Country sub-entity identification	C an..9	O	
3251 Postcode identification	C an..9	O	
3207 Country, coded	C an..3	O	ISO 3166 two alpha country code.

SG4 - 9999 LIN-DTM-RFF-BUS-FCA-SG5-SG6-SG7-SG8-SG9-SG10-SG11				
SG11 - 9999 SEQ-MOA-DTM-RFF-PAI-FCA-SG12-SG13-SG14-SG15-SG16				
SG16 - 1 PRC-FTX-SG17-SG23				
SG17 - 9999 DOC-MOA-DTM-RFF-NAD-SG18-SG19-SG20				
SG18 - 5 CUX-DTM				
UN/EDIFACT Directory 96.A C		D6 O		CRG O
A group of segments specifying the currencies and the related dates/ periods valid to the referenced document where different to the reference currency.		The contents of this segment group are specified by the trading partners' requirements. The user handbook issuer is not liable for the content and usage of details of payment specified in this segment group. The usage of codes in this segment group should be in line with those of the customer-to-customer remittance advice.		
CUX - 1 Currencies				
UN/EDIFACT Directory 96.A M		D6 M		CRG M
A segment identifying the currency and associated exchange rate of the referenced document where different to the remittance currency.		The contents of this segment are specified by trading partners' requirements. The usage of codes in this segment should be in line with those of the customer-to-customer remittance advice.		
Segment number : 68				
UN/EDIFACT Directory 96.A		D6 Description		CRG Description
C504 Currency details	C	O		
6347 Currency details qualifier	M an..3	M		
6345 Currency, coded	C an..3	O		
6343 Currency qualifier	C an..3	O		
6348 Currency rate base	C n..4	O		
C504 Currency details	C	O		
6347 Currency details qualifier	M an..3	M		
6345 Currency, coded	C an..3	O		
6343 Currency qualifier	C an..3	O		
6348 Currency rate base	C n..4	O		
5402 Rate of exchange	C n..12	O		
6341 Currency market exchange, coded	C an..3	O		

SG4 - 9999 LIN-DTM-RFF-BUS-FCA-SG5-SG6-SG7-SG8-SG9-SG10-SG11			
SG11 - 9999 SEQ-MOA-DTM-RFF-PAI-FCA-SG12-SG13-SG14-SG15-SG16			
SG16 - 1 PRC-FTX-SG17-SG23			
SG17 - 9999 DOC-MOA-DTM-RFF-NAD-SG18-SG19-SG20			
SG18 - 5 CUX-DTM			
DTM - 1 Date/time/period			
UN/EDIFACT Directory 96.A C		D6 O	
A segment specifying the date/time/period related to the rate of exchange.		The contents of this segment are specified by trading partners' requirements. The usage of codes in this segment should be in line with those of the customer-to-customer remittance advice.	
Segment number : 69			
UN/EDIFACT Directory 96.A		D6 Description	
CRG Description			
C507 Date/time/period	M	M	
2005 Date/time/period qualifier	M an..3	M	
2380 Date/time/period	C an..35	O	
2379 Date/time/period format qualifier	C an..3	O	

SG4 - 9999 LIN-DTM-RFF-BUS-FCA-SG5-SG6-SG7-SG8-SG9-SG10-SG11			
SG11 - 9999 SEQ-MOA-DTM-RFF-PAI-FCA-SG12-SG13-SG14-SG15-SG16			
SG16 - 1 PRC-FTX-SG17-SG23			
SG17 - 9999 DOC-MOA-DTM-RFF-NAD-SG18-SG19-SG20			
SG19 - 100 AJT-MOA-RFF-FTX			
MOA - 1 Monetary amount			
UN/EDIFACT Directory 96.A M		D6 M	
A segment giving the monetary amounts of the adjustments of each reference document (e.g. original amounts, discount amount, etc.). The currency data elements should not be used.		The contents of this segment are specified by trading partners' requirements. The usage of codes in this segment should be in line with those of the customer-to-customer remittance advice.	
Segment number : 71			
UN/EDIFACT Directory 96.A		D6 Description	
CRG Description			
C516 Monetary amount	M	M	
5025 Monetary amount type qualifier	M an..3	M	
5004 Monetary amount	C n..18	O	
6345 Currency, coded	C an..3	O	
6343 Currency qualifier	C an..3	O	
4405 Status, coded	C an..3	O	

SG4 - 9999 LIN-DTM-RFF-BUS-FCA-SG5-SG6-SG7-SG8-SG9-SG10-SG11			
SG11 - 9999 SEQ-MOA-DTM-RFF-PAI-FCA-SG12-SG13-SG14-SG15-SG16			
SG16 - 1 PRC-FTX-SG17-SG23			
SG17 - 9999 DOC-MOA-DTM-RFF-NAD-SG18-SG19-SG20			
SG19 - 100 AJT-MOA-RFF-FTX			
RFF - 1 Reference			
UN/EDIFACT Directory 96.A C		D6 O	
A segment for the inclusion of any additional references related to the reference documents.		The contents of this segment are specified by trading partners' requirements. The usage of codes in this segment should be in line with those of the customer-to-customer remittance advice.	
Segment number : 72			
UN/EDIFACT Directory 96.A		D6 Description	
CRG Description			
C506 Reference	M	M	
1153 Reference qualifier	M an..3	M	
1154 Reference number	C an..35	O	
1156 Line number	C an..6	O	
4000 Reference version number	C an..35	O	

SG4 - 9999 LIN-DTM-RFF-BUS-FCA-SG5-SG6-SG7-SG8-SG9-SG10-SG11			
SG11 - 9999 SEQ-MOA-DTM-RFF-PAI-FCA-SG12-SG13-SG14-SG15-SG16			
SG16 - 1 PRC-FTX-SG17-SG23			
SG17 - 9999 DOC-MOA-DTM-RFF-NAD-SG18-SG19-SG20			
SG19 - 100 AJT-MOA-RFF-FTX			
FTX - 5 Free text			
UN/EDIFACT Directory 96.A C		D6 O	
A segment providing free text information related to the payment details.		The contents of this segment are specified by trading partners' requirements. The usage of codes in this segment should be in line with those of the customer-to-customer remittance advice.	
Segment number : 73			
UN/EDIFACT Directory 96.A		D6 Description	
		CRG Description	
4451	Text subject qualifier	M an..3	M
4453	Text function, coded	C an..3	O
C107	Text reference	C	O
4441	Free text, coded	M an..3	M
1131	Code list qualifier	C an..3	O
3055	Code list responsible agency, coded	C an..3	O
C108	Text literal	C	O
4440	Free text	M an..70	M
4440	Free text	C an..70	O
4440	Free text	C an..70	O
4440	Free text	C an..70	O
4440	Free text	C an..70	O
3453	Language, coded	C an..3	O

SG4 - 9999 LIN-DTM-RFF-BUS-FCA-SG5-SG6-SG7-SG8-SG9-SG10-SG11				
SG11 - 9999 SEQ-MOA-DTM-RFF-PAI-FCA-SG12-SG13-SG14-SG15-SG16				
SG16 - 1 PRC-FTX-SG17-SG23				
SG17 - 9999 DOC-MOA-DTM-RFF-NAD-SG18-SG19-SG20				
SG20 - 1000 DLI-MOA-PIA-DTM-SG21-SG22				
UN/EDIFACT Directory 96.A C		D6 O		CRG O
A group of segments which may be used when required to provide details of individual line items in the reference document.		The contents of this segment group, i.e. segment groups 20 to 22, are specified by the trading partners' requirements. The user handbook issuer is not liable for the content and usage of details of payment specified in this segment group. The usage of codes in this segment group should be in line with those of the customer-to- customer remittance advice.		
DLI - 1 Document line identification				
UN/EDIFACT Directory 96.A M		D6 M		CRG M
A segment identifying a specific line item within the reference document.		The contents of this segment are specified by trading partners' requirements. The usage of codes in this segment should be in line with those of the customer-to-customer remittance advice.		
Segment number : 74				
UN/EDIFACT Directory 96.A		D6 Description		CRG Description
1073	Document line indicator, coded	M an..3	M	
1082	Line item number	M n..6	M	

SG4 - 9999 LIN-DTM-RFF-BUS-FCA-SG5-SG6-SG7-SG8-SG9-SG10-SG11			
SG11 - 9999 SEQ-MOA-DTM-RFF-PAI-FCA-SG12-SG13-SG14-SG15-SG16			
SG16 - 1 PRC-FTX-SG17-SG23			
SG17 - 9999 DOC-MOA-DTM-RFF-NAD-SG18-SG19-SG20			
SG20 - 1000 DLI-MOA-PIA-DTM-SG21-SG22			
MOA - 5 Monetary amount			
UN/EDIFACT Directory 96.A M		D6 M	
A segment giving the monetary amounts for this line item.		The contents of this segment are specified by trading partners' requirements. The usage of codes in this segment should be in line with those of the customer-to-customer remittance advice.	
Segment number : 75			
UN/EDIFACT Directory 96.A		D6 Description	
CRG Description			
C516 Monetary amount	M	M	
5025 Monetary amount type qualifier	M an..3	M	
5004 Monetary amount	C n..18	O	
6345 Currency, coded	C an..3	O	
6343 Currency qualifier	C an..3	O	
4405 Status, coded	C an..3	O	

SG4 - 9999 LIN-DTM-RFF-BUS-FCA-SG5-SG6-SG7-SG8-SG9-SG10-SG11			
SG11 - 9999 SEQ-MOA-DTM-RFF-PAI-FCA-SG12-SG13-SG14-SG15-SG16			
SG16 - 1 PRC-FTX-SG17-SG23			
SG17 - 9999 DOC-MOA-DTM-RFF-NAD-SG18-SG19-SG20			
SG20 - 1000 DLI-MOA-PIA-DTM-SG21-SG22			
PIA - 5 Additional product id			
UN/EDIFACT Directory 96.A C		D6 O	
A segment specifying item identification codes where required.		The contents of this segment are specified by trading partners' requirements. The usage of codes in this segment should be in line with those of the customer-to-customer remittance advice.	
Segment number : 76			
UN/EDIFACT Directory 96.A		D6 Description	
		CRG Description	
4347 Product id. function qualifier	M an..3	M	
C212 Item number identification	M	M	
7140 Item number	C an..35	O	
7143 Item number type, coded	C an..3	O	
1131 Code list qualifier	C an..3	O	
3055 Code list responsible agency, coded	C an..3	O	
C212 Item number identification	C	O	
7140 Item number	C an..35	O	
7143 Item number type, coded	C an..3	O	
1131 Code list qualifier	C an..3	O	
3055 Code list responsible agency, coded	C an..3	O	
C212 Item number identification	C	O	
7140 Item number	C an..35	O	
7143 Item number type, coded	C an..3	O	
1131 Code list qualifier	C an..3	O	
3055 Code list responsible agency, coded	C an..3	O	
C212 Item number identification	C	O	
7140 Item number	C an..35	O	
7143 Item number type, coded	C an..3	O	
1131 Code list qualifier	C an..3	O	
3055 Code list responsible agency, coded	C an..3	O	

SG4 - 9999 LIN-DTM-RFF-BUS-FCA-SG5-SG6-SG7-SG8-SG9-SG10-SG11			
SG11 - 9999 SEQ-MOA-DTM-RFF-PAI-FCA-SG12-SG13-SG14-SG15-SG16			
SG16 - 1 PRC-FTX-SG17-SG23			
SG17 - 9999 DOC-MOA-DTM-RFF-NAD-SG18-SG19-SG20			
SG20 - 1000 DLI-MOA-PIA-DTM-SG21-SG22			
DTM - 5 Date/time/period			
UN/EDIFACT Directory 96.A C		D6 O	
A segment specifying the date/time/period related to the line item.		The contents of this segment are specified by trading partners' requirements. The usage of codes in this segment should be in line with those of the customer-to-customer remittance advice.	
Segment number : 77			
UN/EDIFACT Directory 96.A		D6 Description	
CRG Description			
C507	Date/time/period	M	M
2005	Date/time/period qualifier	M an..3	M
2380	Date/time/period	C an..35	O
2379	Date/time/period format qualifier	C an..3	O

SG4 - 9999 LIN-DTM-RFF-BUS-FCA-SG5-SG6-SG7-SG8-SG9-SG10-SG11			
SG11 - 9999 SEQ-MOA-DTM-RFF-PAI-FCA-SG12-SG13-SG14-SG15-SG16			
SG16 - 1 PRC-FTX-SG17-SG23			
SG17 - 9999 DOC-MOA-DTM-RFF-NAD-SG18-SG19-SG20			
SG20 - 1000 DLI-MOA-PIA-DTM-SG21-SG22			
SG21 - 5 CUX-DTM			
UN/EDIFACT Directory 96.A C		D6 O	
A group of segments specifying the currencies and the related dates/ periods valid to the referenced document where different to the reference currency.		The contents of this segment group are specified by the trading partners' requirements. The user handbook issuer is not liable for the content and usage of details of payment specified in this segment group. The usage of codes in this segment group should be in line with those of the customer-to-customer remittance advice.	
CUX - 1 Currencies			
UN/EDIFACT Directory 96.A M		D6 M	
A segment identifying the currency and associated exchange rate of the referenced document where different to the remittance currency.		The contents of this segment are specified by trading partners' requirements. The usage of codes in this segment should be in line with those of the customer-to-customer remittance advice.	
Segment number : 78			
UN/EDIFACT Directory 96.A		D6 Description	
CRG Description			
C504 Currency details	C	O	
6347 Currency details qualifier	M an..3	M	
6345 Currency, coded	C an..3	O	
6343 Currency qualifier	C an..3	O	
6348 Currency rate base	C n..4	O	
C504 Currency details	C	O	
6347 Currency details qualifier	M an..3	M	
6345 Currency, coded	C an..3	O	
6343 Currency qualifier	C an..3	O	
6348 Currency rate base	C n..4	O	
5402 Rate of exchange	C n..12	O	
6341 Currency market exchange, coded	C an..3	O	

SG4 - 9999 LIN-DTM-RFF-BUS-FCA-SG5-SG6-SG7-SG8-SG9-SG10-SG11			
SG11 - 9999 SEQ-MOA-DTM-RFF-PAI-FCA-SG12-SG13-SG14-SG15-SG16			
SG16 - 1 PRC-FTX-SG17-SG23			
SG17 - 9999 DOC-MOA-DTM-RFF-NAD-SG18-SG19-SG20			
SG20 - 1000 DLI-MOA-PIA-DTM-SG21-SG22			
SG21 - 5 CUX-DTM			
DTM - 1 Date/time/period			
UN/EDIFACT Directory 96.A C		D6 O	
A segment specifying the date/time/period related to the rate of exchange.		The contents of this segment are specified by trading partners' requirements. The usage of codes in this segment should be in line with those of the customer-to-customer remittance advice.	
Segment number : 79			
UN/EDIFACT Directory 96.A		D6 Description	
CRG Description			
C507 Date/time/period	M	M	
2005 Date/time/period qualifier	M an..3	M	
2380 Date/time/period	C an..35	O	
2379 Date/time/period format qualifier	C an..3	O	

SG4 - 9999 LIN-DTM-RFF-BUS-FCA-SG5-SG6-SG7-SG8-SG9-SG10-SG11			
SG11 - 9999 SEQ-MOA-DTM-RFF-PAI-FCA-SG12-SG13-SG14-SG15-SG16			
SG16 - 1 PRC-FTX-SG17-SG23			
SG17 - 9999 DOC-MOA-DTM-RFF-NAD-SG18-SG19-SG20			
SG20 - 1000 DLI-MOA-PIA-DTM-SG21-SG22			
SG22 - 10 AJT-MOA-RFF-FTX			
MOA - 1 Monetary amount			
UN/EDIFACT Directory 96.A M		D6 M	
A segment giving the monetary amounts of the adjustments of each reference document (e.g. original amounts, discount amounts, etc.). The currency data elements should not be used.		The contents of this segment are specified by trading partners' requirements. The usage of codes in this segment should be in line with those of the customer-to-customer remittance advice.	
Segment number : 81			
UN/EDIFACT Directory 96.A		D6 Description	
CRG Description			
C516 Monetary amount	M	M	
5025 Monetary amount type qualifier	M an..3	M	
5004 Monetary amount	C n..18	O	
6345 Currency, coded	C an..3	O	
6343 Currency qualifier	C an..3	O	
4405 Status, coded	C an..3	O	

SG4 - 9999 LIN-DTM-RFF-BUS-FCA-SG5-SG6-SG7-SG8-SG9-SG10-SG11			
SG11 - 9999 SEQ-MOA-DTM-RFF-PAI-FCA-SG12-SG13-SG14-SG15-SG16			
SG16 - 1 PRC-FTX-SG17-SG23			
SG17 - 9999 DOC-MOA-DTM-RFF-NAD-SG18-SG19-SG20			
SG20 - 1000 DLI-MOA-PIA-DTM-SG21-SG22			
SG22 - 10 AJT-MOA-RFF-FTX			
RFF - 1 Reference			
UN/EDIFACT Directory 96.A C		D6 O	
A segment for the inclusion of any additional references related to the reference document.		The contents of this segment are specified by trading partners' requirements. The usage of codes in this segment should be in line with those of the customer-to-customer remittance advice.	
Segment number : 82			
UN/EDIFACT Directory 96.A		D6 Description	
C506 Reference		CRG Description	
1153 Reference qualifier	M	M	
1154 Reference number	M an..3	M	
1156 Line number	C an..35	O	
4000 Reference version number	C an..6	O	
	C an..35	O	

SG4 - 9999 LIN-DTM-RFF-BUS-FCA-SG5-SG6-SG7-SG8-SG9-SG10-SG11			
SG11 - 9999 SEQ-MOA-DTM-RFF-PAI-FCA-SG12-SG13-SG14-SG15-SG16			
SG16 - 1 PRC-FTX-SG17-SG23			
SG17 - 9999 DOC-MOA-DTM-RFF-NAD-SG18-SG19-SG20			
SG20 - 1000 DLI-MOA-PIA-DTM-SG21-SG22			
SG22 - 10 AJT-MOA-RFF-FTX			
FTX - 5 Free text			
UN/EDIFACT Directory 96.A C		D6 O	
A segment providing free text information related to the payment details.		The contents of this segment are specified by trading partners' requirements. The usage of codes in this segment should be in line with those of the customer-to-customer remittance advice.	
Segment number : 83			
UN/EDIFACT Directory 96.A		D6 Description	
		CRG Description	
4451	Text subject qualifier	M an..3	M
4453	Text function, coded	C an..3	O
C107	Text reference	C	O
4441	Free text, coded	M an..3	M
1131	Code list qualifier	C an..3	O
3055	Code list responsible agency, coded	C an..3	O
C108	Text literal	C	O
4440	Free text	M an..70	M
4440	Free text	C an..70	O
4440	Free text	C an..70	O
4440	Free text	C an..70	O
4440	Free text	C an..70	O
4440	Free text	C an..70	O
3453	Language, coded	C an..3	O

SG4 - 9999 LIN-DTM-RFF-BUS-FCA-SG5-SG6-SG7-SG8-SG9-SG10-SG11			
SG11 - 9999 SEQ-MOA-DTM-RFF-PAI-FCA-SG12-SG13-SG14-SG15-SG16			
SG16 - 1 PRC-FTX-SG17-SG23			
SG23 - 1 GIS-MOA			
UN/EDIFACT Directory 96.A C		D6 O	
A group of segments indicating the end of the details of payment and specifying hash total amounts for control purposes.		The contents of this SG are specified by trading partners' requirements. The usage of codes in this SG should be in line with those of the customer-to-customer remittance advice. National scenarios may apply.	
GIS - 1 General indicator			
UN/EDIFACT Directory 96.A M		D6 M	
A segment identifying the end of the details of payment.		The contents of this segment are specified by trading partners' requirements. The usage of codes in this segment should be in line with those of the customer-to-customer remittance advice. National scenarios may apply.	
Segment number : 84			
UN/EDIFACT Directory 96.A		D6 Description	
C529 Processing indicator		M	
7365 Processing indicator, coded	M an..3	M	37 = Complete information
1131 Code list qualifier	C an..3	N	
3055 Code list responsible agency, coded	C an..3	N	
7187 Process type identification	C an..17	N	
<u>Example:</u>			
GIS+37'			

SG4 - 9999 LIN-DTM-RFF-BUS-FCA-SG5-SG6-SG7-SG8-SG9-SG10-SG11			
SG11 - 9999 SEQ-MOA-DTM-RFF-PAI-FCA-SG12-SG13-SG14-SG15-SG16			
SG16 - 1 PRC-FTX-SG17-SG23			
SG23 - 1 GIS-MOA			
MOA - 5 Monetary amount			
UN/EDIFACT Directory 96.A C		D6 O	
A segment indicating total amounts for control purposes.		CRG N	
Segment number : 85		Not used	
UN/EDIFACT Directory 96.A		D6 Description	
CRG Description			
C516 Monetary amount	M	M	
5025 Monetary amount type qualifier	M an..3	M	
5004 Monetary amount	C n..18	R	
6345 Currency, coded	C an..3	N	
6343 Currency qualifier	C an..3	N	
4405 Status, coded	C an..3	N	
<u>Example:</u>			
MOA+128:23800'			

CNT - 5 Control total					
UN/EDIFACT Directory 96.A C			D6 R		CRG R
A segment providing information on control totals.					
Segment number : 86					
UN/EDIFACT Directory 96.A			D6 Description		CRG Description
C270 Control	M	M			
6069 Control qualifier	M an..3	M	*	2 = Number of line items in message (LIN segments). 39 = Total number of individual transactions (= total number of occurrences of SEQ segments). The usage of code 2 is recommended.	
			*		
6066 Control value	M n..18	M			
6411 Measure unit qualifier	C an..3	N			
<u>Example:</u>					
CNT+2:1'					

SG24 - 5 AUT-DTM				
UN/EDIFACT Directory 96.A C		D6 O		CRG N
A group of segments specifying details of any authentication (validation) procedures applied to the DIRDEB message.		The use of this segment group, including algorithms and calculation procedures, is dependent on bilaterally agreed conditions between the sender and the receiver.		Not used
AUT - 1 Authentication result				
UN/EDIFACT Directory 96.A M		D6 M		CRG N
A segment specifying the details of any authentication (validation) procedures applied to the DIRDEB message.				Not used
Segment number : 87				
UN/EDIFACT Directory 96.A		D6 Description		CRG Description
9280 Validation result	M an..35	M		
9282 Validation key identification	C an..35	O		
<u>Example:</u>				
AUT+283926+HDKGJDSFDS'				

SG24 - 5 AUT-DTM			
DTM - 1 Date/time/period			
UN/EDIFACT Directory 96.A C		D6 R	
A segment identifying the validation date/time.		CRG N	
Segment number : 88			
UN/EDIFACT Directory 96.A		D6 Description	
CRG Description			
C507 Date/time/period	M	M	
2005 Date/time/period qualifier	M an..3	M	218 = Authentication/validation date/time
2380 Date/time/period	C an..35	R	
2379 Date/time/period format qualifier	C an..3	R	102 = CCYYMMDD 203 = CCYYMMDDHHMM
<u>Example:</u>			
DTM+218:20000124:102'			

UNT - 1 MESSAGE TRAILER					
UN/EDIFACT Directory 96.A M		D6 M		CRG M	
A service segment ending a message, giving the total number of segments in the message and the control reference number of the message.					
Segment number : 89					
UN/EDIFACT Directory 96.A		D6 Description		CRG Description	
0074	Number of segments in a message	M n..6	M		
0062	Message reference number	M an..14	M		
				This data element must have the same value as data element 0062 in the UNH segment, a sender-generated sequence number unique within an interchange	
<u>Example:</u>					
UNT+87+20000124AKMJRF'					

4. History of changes

This DIRDEB MIG, version 1.1 of August 2000 contains the following changes, as compared to the previous version:

- Chapter 1 - Introduction New section.
- Chapter 2 - Message Layout New section.
- Chapter 3 - Segment Layout Addition of section "Introduction".
- Chapter 3.2. - Segment Description Layout of table altered, Consistency of descriptions improved.
- Chapter 4 - History of changes New section.

Changes from version 1v1 to 1v2 of February 2001:

- Chapter 1.3 Description corrected
- Chapter 3.2 CRG description block added
- Chapter 3.2 BGM-4343: *R instead of *
- SG4-LIN-1229: a sentence was added that usually *debit* advice is meant
- Description from SG5-MOA-5004 ("decimal comma or dot") copied to SG11-MOA-5004
- SG5-CUX: Currency exchange rate marked as dependent, comment added
- SG23: Changed from "D" to "O"

Changes from version 1v2 to 1v2.1 of May 2001:

- SG 14 INP:C522 Changed from "O" to "D" and add the dependency rule.
- SG 14 FTX Changed from "O" to "D" and add the dependency rule.

Changes from version 1v2.1 to 1v2.2 of July 2001:

- BGM-1001 Code "447" (Collection order) deleted
- SG 12 FII-C078-3194 Description added: "In certain national circumstances this will be an identification which leads to the account information."
- SG 4 BUS-C551 Changed from "N" to "O", description added

Changes from version 1v2.2 to 1v2.3 of November 2001:

- SG 11 DTM C507 2005 Exchange temporary code XF2 with final 749

Changes from version 1v2.3 to 1v2.4 of January 2002:

- SG 4 RFF C506 1153 Add CT = Contract number; Contract number between creditor and the creditors financial institution (or agents) which allows the creditor to raise direct debits.