

PAYMUL D.96A

Multiple payment order message

Recommendation of D6 EWG sub-working group Finance

for the use of the UN/EDIFACT-Message

Version 1.1 from July 31, 2000

Table of contents

Table of contents	1
1. Introduction	2
1.1. Scope	2
1.1.1. Functional Definition	2
1.1.2. Field of Application	2
1.1.3. Principles.....	2
1.2. References	3
1.3. Data Segment Clarification	3
1.4. Rules for segments FII and NAD	4
1.4.1. Dependencies of FII and NAD relevant for transactions in PAYMUL and DIRDEB D.96A.....	4
1.4.2. Directory D.96A: Major parties involved in transaction.....	5
1.4.3. Logical differences between MIGs of D.96A and of D.91.2.....	5
1.5. Codes to be used in DE 1131 and DE 3055 (associated with DE 3434 – Institution Branch Number)	7
2. Message Layout	10
2.1. Branching Diagram	10
2.2. Message Structure	15
3. Segment Layout	19
3.1. Introduction	19
3.1.1. UN/EDIFACT Directory 96.A Block	19
3.1.2. D6 Description Block.....	19
3.1.3. CRG Description Block	21
3.2. Segment Description	21
4. History of changes	122

1. Introduction

This specification provides the definition of the Multiple payment order message (PAYMUL) to be used in Electronic Data Interchange (EDI) between trading partners involved in administration, commerce and transport.

1.1. Scope

1.1.1. Functional Definition

A Multiple Payment order is sent by the Ordering Customer (or Payor or Agent on behalf of the Ordering Customer) to the Ordered Bank, to instruct the Ordered Bank to debit an account it services for the Ordering Customer, and to arrange for the payment of specified amounts to several Beneficiaries (or Payees) in settlement of the referenced business transaction(s).

Throughout this document, the term 'Ordering Customer' refers to either an Ordering Customer, or a Payor or Agent acting (sending) on behalf of the Ordering Customer; likewise the term 'Beneficiary' refers to either a Beneficiary, or a Payee or Agent acting on behalf of the Beneficiary.

1.1.2. Field of Application

This message may be applied for both national and international settlements. It is based on universal practice and is not dependent on the type of business or industry.

1.1.3. Principles

- A Multiple Payment Order may cover the financial settlement of one or more commercial trade transactions such as invoices credit notes, debit notes etc. It is not intended for use in securities trading.
- Charges may be borne on account(s) different of the account(s) held by the Ordering Customer.
- Several debit accounts, execution dates and currencies may be specified.
- The Ordered Bank may need a confirmation/authorisation (e.g. AUTHOR message) to be allowed to process the Multiple Payment Order message.
- The only way to modify a Multiple Payment Order message is to cancel the whole message or part thereof (e.g. by the use of the FINCAN message). In that respect, one to many order(s) could be cancelled within the message, avoiding to be obliged to cancel the whole message.

1.2. References

This document is based on:

Title	Version	Remarks	Source
ISO 9735 Electronic data interchange for administration, commerce and transport (EDIFACT) – Application level syntax rules	Syntax version number: 3		http://www.iso.ch/cate/cat.html
ISO 646 Information processing – ISO 7-bit coded character set for information interchange			http://www.iso.ch/cate/cat.html
UNITED NATIONS TRADE DATA INTERCHANGE DIRECTORY (UNTDID)	D.96A	Definition PAYMUL	http://www.unece.org/trade/untdid
UNITED NATIONS TRADE DATA INTERCHANGE DIRECTORY (UNTDID)	D.00B	UNCL (codelist) only	http://www.unece.org/trade/untdid
Recommended Practice For Message Flow And Security For EDIFACT Payments (D6)	Version 2.03	D6_RecPract_2v03.pdf	http://www.edifact-wg.org
PAYMUL D.96A Multiple payment order message, Recommendation of D6 Sub Working Group Finance for the use of the UN/EDIFACT Message	Version 1.0	Paymul_19990414.rtf	
D6 Referencing Rules and Recommendations	Version 1.1	D6_RefRules_1v01.pdf	http://www.edifact-wg.org

1.3. Data Segment Clarification

The following semantic principles applying to the message are intended to facilitate the understanding of the message:

The Multiple Payment Order message is structured in three levels:

- A level contains data related to the whole message and is contained in Segment Group 1 and Segment Group 2 and the Heading section.
- B level contains data from the debit side (one debit account, one currency, one execution date) and data which applies to all further details of C level(s) and is contained in Segment Group 3 through Segment Group 9.

- C level contains mainly data related to the credit side, and this data is considered as unique for each payment transaction and is contained in Segment Group 10 through Segment Group 21.

The structure of the message is designed to allow several B levels, each B level being followed by its related C levels.

Where a choice of code or text is given only the code element should be used wherever possible.

1.4. Rules for segments FII and NAD

1.4.1. Dependencies of FII and NAD relevant for transactions in PAYMUL and DIRDEB D.96A

	PAYMUL level B Party Qualifier (DE 3035)	PAYMUL level C Party Qualifier (DE 3035)	DIRDEB level B Party Qualifier (DE 3035)	DIRDEB level C Party Qualifier (DE 3035)
Only FII, no NAD. C078 must contain the account holder name.	FII+OR	FII+BF	FII+BF	FII+PH
No FII, only 1 NAD. Full address is required.	<i>Not allowed</i>	NAD+BE	<i>Not allowed</i>	<i>Not allowed</i>
FII and 1 NAD; both defining the same party (account owner). FII-C078 must not contain the account holder name.	FII+OR NAD+PL	FII+BF NAD+PE	FII+BF NAD+PE	FII+PH NAD+PL
FII and 1 NAD; NAD defining a party different to the account owner in FII. FII-C078 must contain the account holder name.	FII+OR NAD+OY	FII+BF NAD+BE	FII+BF NAD+BE	FII+PH NAD+HX
FII and 2 NAD; one NAD defining the account owner (FII-C078 must not contain the account holder name) and one NAD defining a party different to the account owner in FII (full address is required).	FII+OR NAD+PL NAD+OY	FII+BF NAD+PE NAD+BE	FII+BF NAD+PE NAD+BE	FII+PH NAD+PL NAD+HX

1.4.2. Directory D.96A: Major parties involved in transaction

Message D.96A	Level B			Level C		
	Ordering customer (other than the account owner)		Account owner on the ordering side	(FII+I1)	Account owner on the receiving side	Receiving party (other than the account owner)
PAYMUL	NAD+OY	→	FII+OR NAD+PL	→	FII+BF NAD+PE	→ NAD+BE
PAYMUL	NAD+OY	→	FII+OR NAD+PL	→	FII+BQ	→ NAD+RV NAD+BE
DIRDEB	NAD+BE	→	FII+BF NAD+PE	→	FII+PH NAD+PL	→ NAD+HX

1.4.3. Logical differences between MIGs of D.96A and of D.91.2

Directory D.96A	Directory 91.2	Comment to the differences in PAYMUL D.96A and PAYORD 91.2
<i>Level B</i>		
FII+OR	FII+OR	No differences
FII+OR NAD+PL	FII+OR NAD+OY	If ordering customer and account owner (FII+OR) on the ordering side are the same, additional address details have to be added in different NAD segments: <ul style="list-style-type: none"> In D.96A NAD+PL defines always the account owner In 91.2 NAD+OY defines the account owner only if no NAD+PL exists
FII+OR NAD+OY	FII+OR NAD+PL	If ordering customer and account owner (FII+OR) on the ordering side are not the same, additional address details have to be added in different NAD segments: <ul style="list-style-type: none"> In D.96A NAD+OY defines always an ordering party different to the account owner

	NAD+OY	<ul style="list-style-type: none"> In 91.2 NAD+OY defining an ordering party different to the account owner is only allowed together with an NAD+PL defining the account owner
FII+OR NAD+PL NAD+OY	FII+OR NAD+PL NAD+OY	<p>No differences:</p> <p>NAD+PL defines the same party as FII+OR (=account owner), and</p> <p>NAD+OY defines an ordering customer other than the account owner.</p>
<i>Level C</i>		
FII+BF	FII+BF	No differences
FII+BF NAD+PE	FII+BF NAD+BE	<p>If final beneficiary and account owner (FII+BF) on the receiving side are the same, additional address details have to be added in different NAD segments:</p> <ul style="list-style-type: none"> In D.96A NAD+PE defines always the account owner In 91.2 NAD+BE defines the account owner only if no NAD+PE exists
FII+BF NAD+BE	FII+BF NAD+PE NAD+BE	<p>If final beneficiary and account owner (FII+BF) on the receiving side are not the same, additional address details have to be added in different NAD segments:</p> <ul style="list-style-type: none"> In D.96A NAD+BE defines always a final beneficiary different to the account owner In 91.2 NAD+BE defining a final beneficiary different to the account owner is only allowed together with an NAD+PE defining the account owner
FII+BF NAD+PE NAD+BE	FII+BF NAD+PE NAD+BE	<p>No differences:</p> <p>NAD+PE defines the same party as FII+BF (=account owner), and</p> <p>NAD+BE defines a final beneficiary other than the account owner.</p>

1.5. Codes to be used in DE 1131 and DE 3055 (associated with DE 3434 – Institution Branch Number)

DE3434 – DE1131 (Code List Qualifier)	25 = Bank identification
	43 = CHIPS Participant ID
	44 = CHIPS Universal ID
	154 = Bank branch sorting identification
	155 = Automated clearing house
	157 = Clearing code
DE3434 – DE3055 (Code List Responsible Agency, coded)	5 = ISO (International Organization for Standardization)
	19 = FRRC (Federal Reserve Routing Code)
	108 = FR, Banque de France
	114 = US, ABA (American Bankers Association)
	118 = SE, Svenska Bankfoereningen
	119 = IT, Associazione Bancaria Italiana
	121 = CH, Telekurs AG
	122 = CH, Swiss Securities Clearing Corporation
	124 = NO, Norwegian Bankers Ass.
	125 = FI, The Finnish Bankers' Association
	128 = BE, Belgian Bankers' Association
	130 = DK, PBS (Pengainstitutternes Betalings Service)
	131 = DE, German Bankers Association

133 = GB, Association for Payment Clearing Services
137 = AT, Verband oesterreichischer Banken und Bankiers
171 = NL, Interpay Girale Services
202 = PT, Banco de Portugal
275 = ES, Banco de España
ZA7 = TW, Taiwanese Bankers' Association (D6 code)
Zxx = If no code exists, then "Z" + "ISO 3166 two alpha country code"

These codes should be combined as indicated in the following table:

To identify a financial institution by the following code	1131 Code	3055 Code
ISO Bank Identifier Code	25	5
Fedwire Id	25	19
French Bank Code	25	108
Swedish Bank Clearing Number	157	118
Italian Bank Code	25	119
Swiss Bank Clearing Number	157	121
Norwegian Bank Code	25	124
Finnish Bank Code	25	125
Belgian Bank Code	25	128
Danish Bank Code	25	130

German Bankleitzahl	25	131
GB Bank Sort Code	154	133
Austrian Bankleitzahl	25	137
Dutch Bank Code	25	171
Portuguese Bank Code	25	202
Portuguese Clearing House Code	155	202
Spanish Bank code	25	275
Chinese Taipei Bank Code	154	ZA7 (D6 code)
CHIPS Participant ID	43	114
CHIPS Universal ID	44	114

2. Message Layout

2.1. Branching Diagram

The use of the shadowed segments is either not recommended or depends upon national requirements. These segments are marked with **N** in the chapter “Segment Layout” without further description.

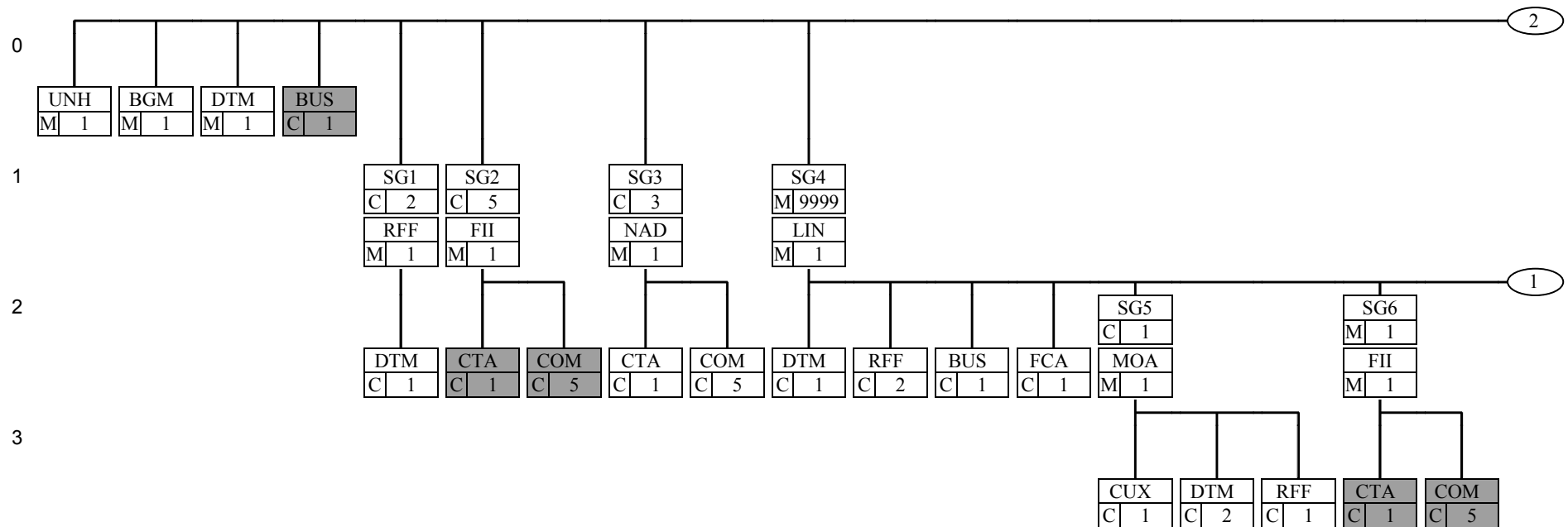

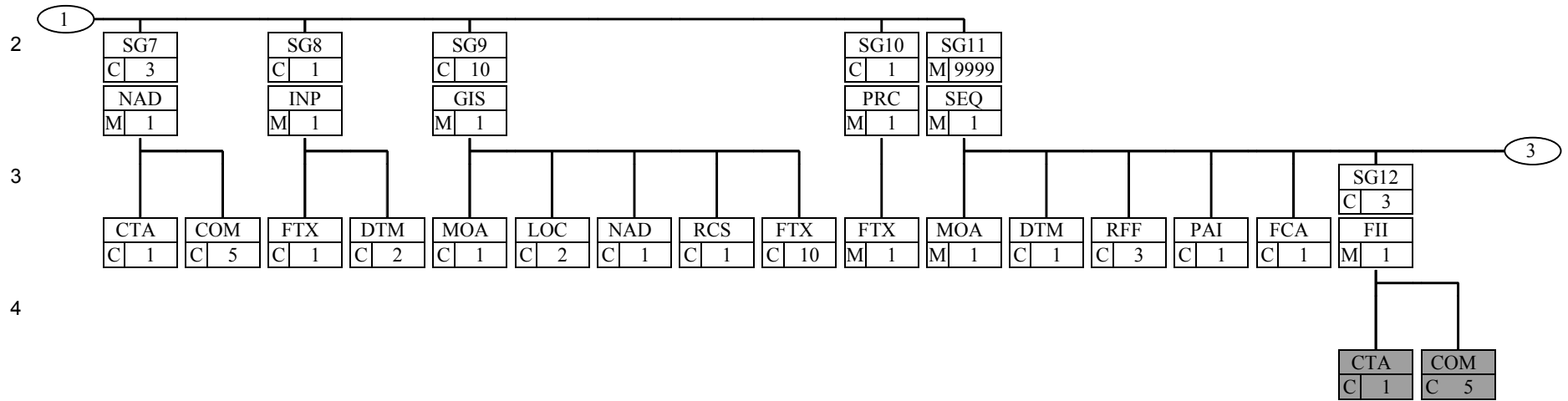

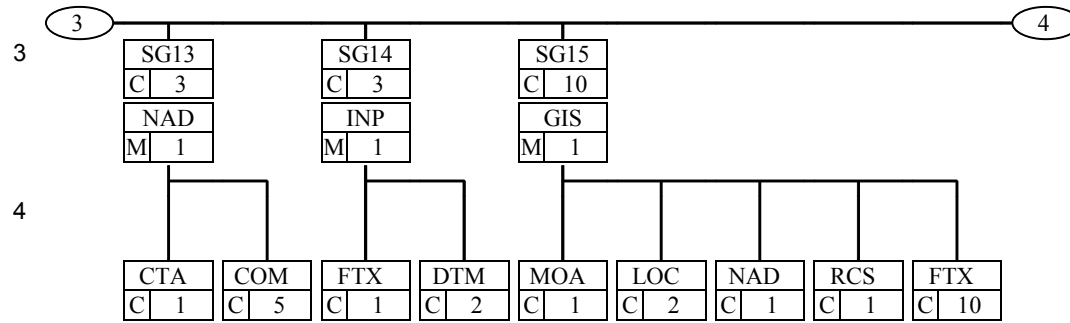

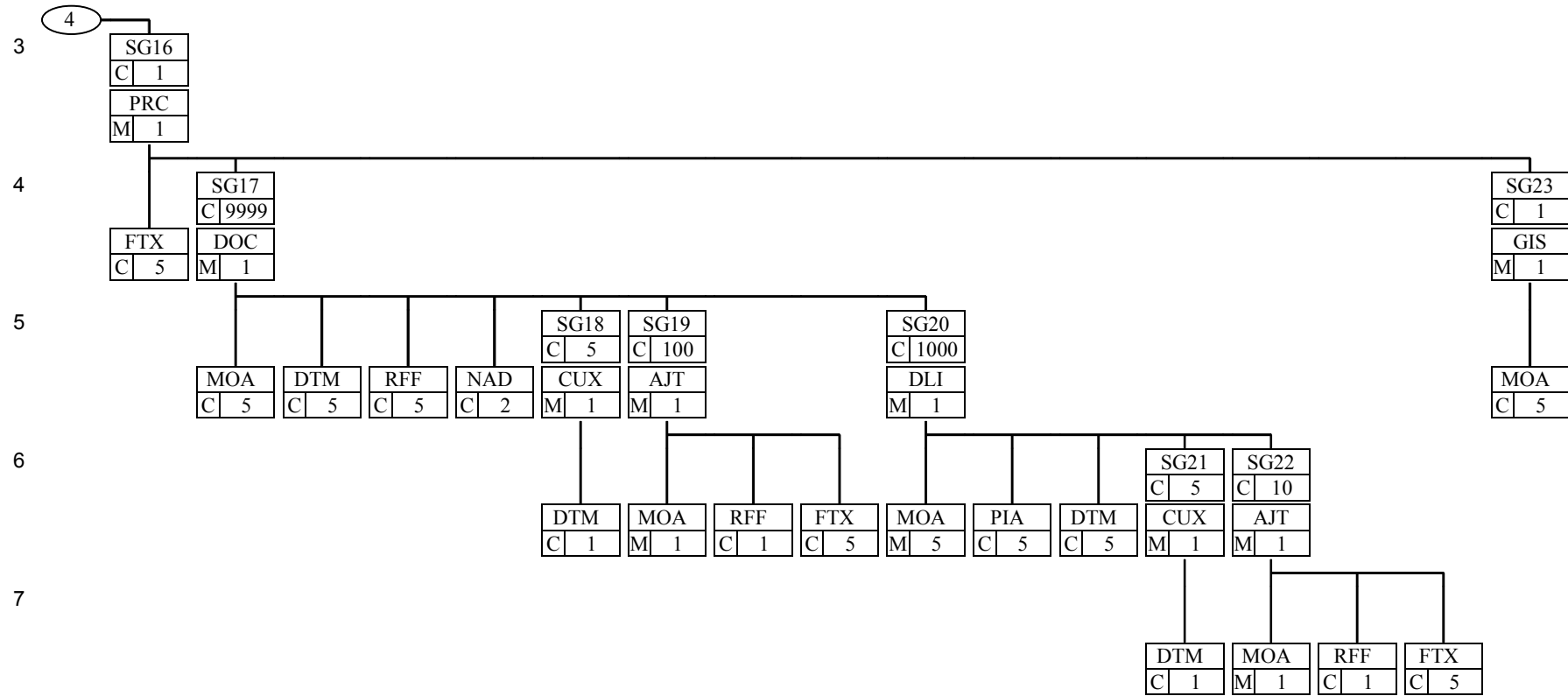

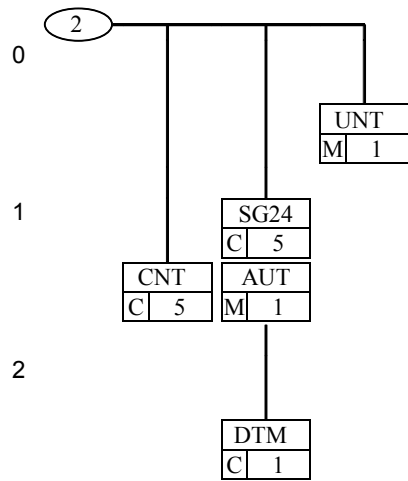

2.2. Message Structure

Pos	Tag Name	S	R
0010	UNH Message header	M	1
0020	BGM Beginning of message	M	1
0030	DTM Date/time/period	M	1
0040	BUS Business function	C	1
0050	----- Segment group 1 -----	C	2-----
0060	RFF Reference	M	1
0070	DTM Date/time/period	C	1-----
0080	----- Segment group 2 -----	C	5-----
0090	FII Financial institution information	M	1
0100	CTA Contact information	C	1
0110	COM Communication contact	C	5-----
0120	----- Segment group 3 -----	C	3-----
0130	NAD Name and address	M	1
0140	CTA Contact information	C	1
0150	COM Communication contact	C	5-----
0160	----- Segment group 4 -----	M	9999-----
0170	LIN Line item	M	1
0180	DTM Date/time/period	C	1
0190	RFF Reference	C	2
0200	BUS Business function	C	1
0210	FCA Financial charges allocation	C	1
0220	----- Segment group 5 -----	C	1-----
0230	MOA Monetary amount	M	1
0240	CUX Currencies	C	1
0250	DTM Date/time/period	C	2
0260	RFF Reference	C	1-----
0270	----- Segment group 6 -----	M	1-----

0280	FII	Financial institution information	M	1
0290	CTA	Contact information	C	1
0300	COM	Communication contact	C	5-----
0310		----- Segment group 7 -----	C	3-----
0320	NAD	Name and address	M	1
0330	CTA	Contact information	C	1
0340	COM	Communication contact	C	5-----
0350		----- Segment group 8 -----	C	1-----
0360	INP	Parties to instruction	M	1
0370	FTX	Free text	C	1
0380	DTM	Date/time/period	C	2-----
0390		----- Segment group 9 -----	C	10-----
0400	GIS	General indicator	M	1
0410	MOA	Monetary amount	C	1
0420	LOC	Place/location identification	C	2
0430	NAD	Name and address	C	1
0440	RCS	Requirements and conditions	C	1
0450	FTX	Free text	C	10-----
0460		----- Segment group 10 -----	C	1-----
0470	PRC	Process identification	M	1
0480	FTX	Free text	M	1-----
0490		----- Segment group 11 -----	M	9999-----
0500	SEQ	Sequence details	M	1
0510	MOA	Monetary amount	M	1
0520	DTM	Date/time/period	C	1
0530	RFF	Reference	C	3
0540	PAI	Payment instructions	C	1
0550	FCA	Financial charges allocation	C	1
0560		----- Segment group 12 -----	C	3-----
0570	FII	Financial institution information	M	1
0580	CTA	Contact information	C	1
0590	COM	Communication contact	C	5-----
0600		----- Segment group 13 -----	C	3-----

0610	NAD Name and address	M	1
0620	CTA Contact information	C	1
0630	COM Communication contact	C	5-----
0640	----- Segment group 14 -----	C	3-----
0650	INP Parties to instruction	M	1
0660	FTX Free text	C	1
0670	DTM Date/time/period	C	2-----
0680	----- Segment group 15 -----	C	10-----
0690	GIS General indicator	M	1
0700	MOA Monetary amount	C	1
0710	LOC Place/location identification	C	2
0720	NAD Name and address	C	1
0730	RCS Requirements and conditions	C	1
0740	FTX Freetext	C	10-----
0750	----- Segment group 16 -----	C	1-----
0760	PRC Process identification	M	1
0770	FTX Free text	C	5
0780	----- Segment group 17 -----	C	9999-----
0790	DOC Document/message details	M	1
0800	MOA Monetary amount	C	5
0810	DTM Date/time/period	C	5
0820	RFF Reference	C	5
0830	NAD Name and address	C	2
0840	----- Segment group 18 -----	C	5-----
0850	CUX Currencies	M	1
0860	DTM Date/time/period	C	1-----
0870	----- Segment group 19 -----	C	100-----
0880	AJT Adjustment details	M	1
0890	MOA Monetary amount	M	1
0900	RFF Reference	C	1
0910	FTX Free text	C	5-----
0920	----- Segment group 20 -----	C	1000-----
0930	DLI Document line identification	M	1

0940	MOA Monetary amount	M	5				
0950	PIA Additional product id	C	5				
0960	DTM Date/time/period	C	5				
0970	----- Segment group 21 -----	C	5-----				
0980	CUX Currencies	M	1				
0990	DTM Date/time/period	C	1-----				
1000	----- Segment group 22 -----	C	10-----				
1010	AJT Adjustment details	M	1				
1020	MOA Monetary amount	M	1				
1030	RFF Reference	C	1				
1040	FTX Free text	C	5-----				
1050	----- Segment group 23 -----	C	1-----				
1060	GIS General indicator	M	1				
1070	MOA Monetary amount	C	5-----				
1080	CNT Control total	C	5				
1090	----- Segment group 24 -----	C	5-----				
1100	AUT Authentication result	M	1				
1110	DTM Date/time/period	C	1-----				
1120	UNT Message trailer	M	1				

3. Segment Layout

3.1. Introduction

This section describes each segment of the UN/EDIFACT message PAYMUL.

Each segment is presented in a separate table and in the sequence in which they appear in the message.

The upper half of each table provides information about the segment or segment group concerned, the lower part of the table describes the data elements (composite and simple).

Each table is structured in three vertical blocks: UN/EDIFACT Directory 96.A, D6 and CRG:

3.1.1. UN/EDIFACT Directory 96.A Block

The left third of the table provides information extracted from the original UN/EDIFACT Directory 96.A.

In the first line of this block, the segment or segment group tag is followed by the maximum number of occurrences.

The second line contains the (M)andatory / (C)onditional indicator at segment level, according to the UN/EDIFACT Directory 96.A

In the lower half of the table, the data element tag (composite or simple) and full name are followed by the corresponding (M)andatory / (C)onditional indicators and the format.

3.1.2. D6 Description Block

This block presents the recommendations of D6 (EWG sub-working group Finance).

Both for segment level and for data element level (simple and composite), the following status/sub-status are defined:

M	MANDATORY	The entity is mandatory and must be sent (according to directory, unchanged)
R	REQUIRED	The entity is required and must be sent
D	DEPENDENT	The entity must be sent in certain conditions, as defined by the relevant explanatory note
O	OPTIONAL	The entity is optional and may be sent at the discretion of the user
N	NOT USED	The entity is not used and should be omitted. Any data placed in an element marked with N will be ignored.

At data element level:

- The first column indicates the status as defined above (with the options M, R, D, O, N);
- The second column includes information affecting the code values as follows:

*	Restricted codelist	Code values preceded by an asterisk (*) are the only codes available for use in the given context
<blank>	Open codelist	Code values not preceded by an asterisk (*) are not restricted (they are open). The available codes are listed in the codelist of the corresponding UN/EDIFACT directory.
* R	Required code in a restricted list	Codes preceded by an “R” are required and must occur in one repetition of the corresponding segment if used.
R	Required code in an open list	Codes preceded by an “R” are required and must occur in one repetition of the corresponding segment if used.

- The third column provides additional comments and descriptions.

Note that if a segment group/segment/composite data element is flagged as “N”, all data elements within that segment group/segment/composite data element will have blank status indicators.

3.1.3. CRG Description Block

The last block of the table describes the preferred use of the message for a group of multinational companies constituting the "Corporate Reference Group" (CRG). The CRG is established as a forum for discussions of standardisation issues. The members of the group are predominantly companies with activities in several countries and a large resource base.

3.2. Segment Description

See next page

UNH - 1 MESSAGE HEADER				
UN/EDIFACT Directory 96.A M		D6 M	CRG M	
<p>A service segment starting and uniquely identifying a message. The message type code for the Multiple payment order message is PAYMUL.</p> <p>Note: Multiple payment order messages conforming to this document must contain the following data in segment UNH, composite S009:</p> <p>Data element 0065 PAYMUL 0052 D 0054 96A 0051 UN</p>				
Segment number : 1				
UN/EDIFACT Directory 96.A		D6 Description		CRG Description
0062	Message reference number	M an..14	M	This sender-generated sequence number must be unique within an interchange. DE 0062 in the UNT segment must have the same value.
S009	MESSAGE IDENTIFIER	M	M	Incorrect data in this composite DE will cause message rejection.
0065	Message type identifier	M an..6	M *R	PAYMUL
0052	Message type version number	M an..3	M *R	D = Directory
0054	Message type release number	M an..3	M *R	96A = Release 96A
0051	Controlling agency	M an..2	M *R	UN = UN/ECE/TRADE/WP.4, United Nations Standard Messages (UNSM)
0057	Association assigned code	C an..6	O *	FUN01G = Industry/ Country Code/ Version number/ Function, , i.e., Finance/ United Nations/ Version 1/ General
0068	Common access reference	C an..35	N	
S010	STATUS OF THE TRANSFER	C	N	
0070	Sequence message transfer number	M n..2		
0073	First/last sequence message transfer indication	C a1		
<u>Example:</u>				
UNH+19970630MJRF+PAYMUL:D:96A:UN:FUN01G'				

BGM - 1 Beginning of message						
UN/EDIFACT Directory 96.A M			D6 M		CRG M	
A segment by means of which the sender must uniquely identify the PAYMUL message using its type and number and when necessary its function.						
Note: The identification will be passed back to the ordering customer for reconciliation purposes, if a reference is not quoted in the B- level.						
Segment number : 2						
UN/EDIFACT Directory 96.A			D6 Description		CRG Description	
C002 Document/message name	C	R				
1001 Document/message name, coded	C an..3	R	*	452 = Multiple payment order	*	Use only 452 = Multiple payment order
			*	303 = Request for transfer		
1131 Code list qualifier	C an..3	N				
3055 Code list responsible agency, coded	C an..3	N				
1000 Document/message name	C an..35	N				
1004 Document/message number	C an..35	R		Must be unique within the legally binding time of archiving EDI documents. A second PAYMUL message with the same document number but without the code 7 in DE 1225 will be rejected.		
1225 Message function, coded	C an..3	R	*	9 = Original	*	Use only 9 = Original
			*	7 = Duplicate		
				If code 7 is used, then SG 1 is required.		
4343 Response type, coded	C an..3	O	*	AB = Message acknowledgement		DE not used.
				If DE is missing, the acknowledgement of the message together with the responsibility for the receiver will happen as bilaterally agreed.		
<u>Example:</u> BGM+452+3452422040+9'						

DTM - 1 Date/time/period						
UN/EDIFACT Directory 96.A M			D6 M		CRG M	
A segment specifying the date and if required the time when the message is created.						
Segment number : 3						
UN/EDIFACT Directory 96.A			D6 Description		CRG Description	
C507	Date/time/period	M	M			
2005	Date/time/period qualifier	M an..3	M	*R	137 = Document/message date/time	
2380	Date/time/period	C an..35	R		A date in the future can be accepted given the creation of messages across different time zones.	
2379	Date/time/period format qualifier	C an..3	R	*	102 = CCYYMMDD	* Use only 102 = CCYYMMDD
				*	203 = CCYYMMDDHHMM	
<u>Example:</u>						
DTM+137:19970630:102'						

BUS - 1 Business function			
UN/EDIFACT Directory 96.A C		D6 N	CRG N
A segment providing information to the ordered bank to route the message, or for tariffing or for the provision of some statistical information.		Not used.	Not used.
Segment number : 4			
UN/EDIFACT Directory 96.A		D6 Description	CRG Description
C521 Business function	C		
4027 Business function qualifier	M an..3		
4025 Business function, coded	M an..3		
1131 Code list qualifier	C an..3		
3055 Code list responsible agency, coded	C an..3		
4022 Business description	C an..70		
3279 Geographic environment, coded	C an..3		
4487 Type of financial transaction, coded	C an..3		
C551 Bank operation	C		
4383 Bank operation, coded	M an..3		
1131 Code list qualifier	C an..3		
3055 Code list responsible agency, coded	C an..3		
4463 Intra-company payment, coded	C an..3		

SG1 - 2 RFF-DTM				
UN/EDIFACT Directory 96.A C		D6 D		CRG N
A group of segments identifying any previously sent message.		This SG is used only when DE1225 in BGM contains the code 7 (duplicate).		Not used.
RFF - 1 Reference				
UN/EDIFACT Directory 96.A M		D6 M		CRG N
A segment specifying the reference number of another message.		This segment contains the original BGM number of the previously sent message regardless of whether the two BGM numbers are the same.		Not used.
Segment number : 5				
UN/EDIFACT Directory 96.A		D6 Description		CRG Description
C506 Reference	M	M		
1153 Reference qualifier	M an..3	M	*R	ACW = Reference number to previous message BGM 1004 from the original message.
1154 Reference number	C an..35	R		
1156 Line number	C an..6	N		
4000 Reference version number	C an..35	N		
<u>Example:</u>				
RFF+ACW:3452422040'				

SG1 - 2 RFF-DTM					
DTM - 1 Date/time/period					
UN/EDIFACT Directory 96.A C			D6 O		CRG N
A segment identifying the creation date of the referenced message.					
Segment number : 6					
UN/EDIFACT Directory 96.A			D6 Description		CRG Description
C507	Date/time/period	M	M		
2005	Date/time/period qualifier	M an..3	M	*R	171 = Reference date/time
2380	Date/time/period	C an..35	R		Creation date of the original message.
2379	Date/time/period format qualifier	C an..3	R	*	102 = CCYYMMDD
				*	203 = CCYYMMDDHHMM
<u>Example:</u>					
DTM+171:19970630:102'					

SG2 - 5 FII-CTA-COM					
UN/EDIFACT Directory 96.A C		D6 O		CRG N	
A group of segments identifying the financial institutions involved in the multiple payment order and the routing functions with their contacts.		This SG is used for routing purposes only.		Not used.	
FII - 1 Financial institution information					
UN/EDIFACT Directory 96.A M		D6 M		CRG N	
A segment identifying the financial institutions associated with the transaction in coded or uncoded form and their function.				Not used.	
Segment number : 7					
UN/EDIFACT Directory 96.A		D6 Description		CRG Description	
3035 Party qualifier	M an..3	M	*	MR = Message recipient	
			*	AS = Account servicing financial institution.	
				This code is required when code 303 (request for transfer) is used in DE 1001 of BGM.	
C078 Account identification	C	N			
3194 Account holder number	C an..35				
3192 Account holder name	C an..35				
3192 Account holder name	C an..35				
6345 Currency, coded	C an..3				
C088 Institution identification	C	R		The Bank Identifier Code may only be placed in DE 3433. The national bank/branch sorting code may only be placed in DE 3434. DEs 3433 and 3434 are mutually exclusive.	
3433 Institution name identification	C an..11	D			
1131 Code list qualifier	C an..3	D	*R	25 = Bank identification	
3055 Code list responsible agency, coded	C an..3	D	*R	5 = ISO (International Organization for Standardization).	
3434 Institution branch number	C an..17	D			
1131 Code list qualifier	C an..3	D	*	The allowed combinations of the codes of DE1131 and 3055 are stated in Section 1.5. of this MIG.	
3055 Code list responsible agency, coded	C an..3	D	*	The allowed combinations of the codes of DE1131 and 3055 are stated in Section 1.5. of this MIG.	
3432 Institution name	C an..70	N			

3436 Institution branch place	C an..70	N	This DE is used when DE 3434 is used and no country is mentioned in its associated DE 3055. ISO 3166 two alpha country code.
3207 Country, coded	C an..3	D	
<u>Example:</u> FII+MR++DRESDEFF:25:5'			

SG2 - 5 FII-CTA-COM			
CTA - 1 Contact information			
UN/EDIFACT Directory 96.A C		D6 N	
A segment identifying a person or department for the party specified in the leading FII segment and to whom communication should be directed.		Not used.	
Segment number : 8			
UN/EDIFACT Directory 96.A		D6 Description	
3139 Contact function, coded	C an..3		
C056 Department or employee details	C		
3413 Department or employee identification	C an..17		
3412 Department or employee	C an..35		
		CRG Description	

SG2 - 5 FII-CTA-COM		
COM - 5 Communication contact		
UN/EDIFACT Directory 96.A C	D6 N	CRG N
A segment providing communication type(s) and number(s) of person(s) or department(s) specified in the associated CTA segment.	Not used.	Not used.
Segment number : 9		
UN/EDIFACT Directory 96.A	D6 Description	CRG Description
C076 Communication contact	M	
3148 Communication number	M an..512	
3155 Communication channel qualifier	M an..3	

SG3 - 3 NAD-CTA-COM			
UN/EDIFACT Directory 96.A C	D6 O	CRG N	
A group of segments identifying the ordering party, which is valid for all payment orders.	This SG is used for routing purposes only.	Not used.	
NAD - 1 Name and address			
UN/EDIFACT Directory 96.A M	D6 M	CRG N	
Name and address for the ordering customer.		Not used.	
Segment number : 10			
UN/EDIFACT Directory 96.A	D6 Description	CRG Description	
3035 Party qualifier	M an..3 M * * MS = Document/message issuer/sender HQ= Account owner. The usage of this code is subject to national agreement.		
C082 Party identification details	C D Either C082 or DEs C080, C059, 3164, 3229, 3251 and 3207 are used. In this composite only bilaterally agreed codes are allowed.		
3039 Party id. identification	M an..35 M		
1131 Code list qualifier	C an..3 D		
3055 Code list responsible agency, coded	C an..3 D		
C058 Name and address	C N		
3124 Name and address line	M an..35		
3124 Name and address line	C an..35		
3124 Name and address line	C an..35		
3124 Name and address line	C an..35		
3124 Name and address line	C an..35		
C080 Party name	C D Either C082 or DEs C080, C059, 3164, 3229, 3251 and 3207 are used. Use of structured name and address has to be allowed by bilateral agreement.		
3036 Party name	M an..35 M		
3036 Party name	C an..35 O		
3036 Party name	C an..35 O		
3036 Party name	C an..35 N		
3036 Party name	C an..35 N		
3045 Party name format, coded	C an..3 N		
C059 Street	C D		
3042 Street and number/p.o. box	M an..35 M		

3042	Street and number/p.o. box	C	an..35	O			
3042	Street and number/p.o. box	C	an..35	O			
3042	Street and number/p.o. box	C	an..35	N			
3164	City name	C	an..35	D			
3229	Country sub-entity identification	C	an..9	D			
3251	Postcode identification	C	an..9	D			
3207	Country, coded	C	an..3	D		ISO 3166 two alpha country code.	
<u>Example:</u>							
NAD+MS+2729712345832:160:9'							

SG3 - 3 NAD-CTA-COM					
CTA - 1 Contact information					
UN/EDIFACT Directory 96.A C			D6 O		CRG N
A segment identifying a person or a department for the party specified in the leading NAD segment to whom communication should be directed.					Not used.
Segment number : 11					
UN/EDIFACT Directory 96.A			D6 Description		CRG Description
3139 Contact function, coded	C an..3	R	*R	IC = Information contact	
C056 Department or employee details	C	R			
3413 Department or employee identification	C an..17	N			
3412 Department or employee	C an..35	R		The name of the department or employee in free text form.	
<u>Example:</u> CTA+IC+:JIM JOHNSON'					

SG3 - 3 NAD-CTA-COM			
COM - 5 Communication contact			
UN/EDIFACT Directory 96.A C		D6 O	
A segment identifying communication type(s) and number(s) of person(s) or department(s) specified in the associated CTA segment.		CRG N	
A segment identifying communication type(s) and number(s) of person(s) or department(s) specified in the associated CTA segment.		Not used.	
Segment number : 12			
UN/EDIFACT Directory 96.A		D6 Description	
CRG Description			
C076 Communication contact	M	M	
3148 Communication number	M an..512	M	When character sets UNOA or UNOB are used, the @ in e-mail addresses must be shown with (at) (parenthesis, at, parenthesis), e.g. <john.smith(at)abc.com>.
3155 Communication channel qualifier	M an..3	M	FX = Telefax TE = Telephone EM = Electronic mail TL = Telex The use of other codes must be bilaterally agreed.
<u>Example:</u> COM+496926050:TE'			

SG4 - 9999 LIN-DTM-RFF-BUS-FCA-SG5-SG6-SG7-SG8-SG9-SG10-SG11					
UN/EDIFACT Directory 96.A M		D6 M		CRG M	
This segment group contains information regarding the debit side of this transaction and details which are pertinent to all payments specified in the message. Certain payment details may be provided either in segment group 4 or in segment group 11, but not in both.		This B-level contains sorting criteria for transactions contained in the C-level: the account number to be debited, the DTM information in SG4, the currency of the amount to be transferred, the monetary amount type and the geographic environment have to be the same. If any additional DTM information is present in SG11, it has to be the same in each C-level of this B-level.		.	
LIN - 1 Line item					
UN/EDIFACT Directory 96.A M		D6 M		CRG M	
A segment identifying the line item by a current line number.					
Segment number : 13					
UN/EDIFACT Directory 96.A		D6 Description		CRG Description	
1082	Line item number	C n..6	R		DE not used.
1229	Action request/notification, coded	C an..3	O	* * 106 – Advice without details 107 – Advice with details If DE is missing, booking and advising will happen as bilaterally agreed.	
C212	Item number identification	C	N		
7140	Item number	C an..35			
7143	Item number type, coded	C an..3			
1131	Code list qualifier	C an..3			
3055	Code list responsible agency, coded	C an..3			
C829	Sub-line information	C	N		
5495	Sub-line indicator, coded	C an..3			
1082	Line item number	C n..6			
1222	Configuration level	C n..2	N		
7083	Configuration, coded	C an..3	N		
Example: LIN+1'					

SG4 - 9999 LIN-DTM-RFF-BUS-FCA-SG5-SG6-SG7-SG8-SG9-SG10-SG11						
DTM - 1 Date/time/period						
UN/EDIFACT Directory 96.A C			D6 R		CRG R	
A segment identifying the date, at which an order has been requested to be executed or acted upon.						
Segment number : 14						
UN/EDIFACT Directory 96.A			D6 Description		CRG Description	
C507	Date/time/period	M	M			
2005	Date/time/period qualifier	M an..3	M	*R	203 = Execution date/time, requested Execution will only take place on a bank working day.	203 = Execution date/time, requested Subject to national law, execution date means: 1. Payment by cheque: date when cheque is required to be generated/printed by the bank. 2. Bank posting, e.g. payment between two accounts in the same bank: date on which the payment is posted. Value date(s) can differ from posting date. 3. Clearing house, e.g. payment through clearing (domestic or international): date on which the payment is passed on to the clearing system.
2380	Date/time/period	C an..35	R			
2379	Date/time/period format qualifier	C an..3	R	*R	102 = CCYYMMDD	
<u>Example:</u>						
DTM+203:19970630:102'						

SG4 - 9999 LIN-DTM-RFF-BUS-FCA-SG5-SG6-SG7-SG8-SG9-SG10-SG11					
RFF - 2 Reference					
UN/EDIFACT Directory 96.A C		D6 R		CRG R	
A segment specifying the reference of the single debit amount on the debit side of the transaction (B level).					
Note: The identification will be passed back to the Ordering Customer for reconciliation purposes.					
Segment number : 15					
UN/EDIFACT Directory 96.A		D6 Description		CRG Description	
C506 Reference	M	M			
1153 Reference qualifier	M an..3	M	*R	AEK = Payment order number. For more information see D6 Referencing Rules and Recommendations.	
1154 Reference number	C an..35	R			
1156 Line number	C an..6	N			
4000 Reference version number	C an..35	N			
<u>Example:</u> RFF+AEK:12245'					

SG4 - 9999 LIN-DTM-RFF-BUS-FCA-SG5-SG6-SG7-SG8-SG9-SG10-SG11					
BUS - 1 Business function					
UN/EDIFACT Directory 96.A C		D6 D		CRG D	
A segment identifying certain characteristics of the payment orders stored on level C, such as business function.		The absence of this segment means that all the transactions within this B-level are (domestic) clean payments.		This segment should not be used because ideally the distinction between domestic and international payments should be done on transaction/C-level (e.g., currency, bank identification, country code). Currently, this is not possible due to legal/regulatory limitations in some countries and it may be necessary to identify whether the batch is domestic or international within this BUS segment. However, this is not desirable in the long term.	
Segment number : 16					
UN/EDIFACT Directory 96.A		D6 Description		CRG Description	
C521 Business function	C	O			
4027 Business function qualifier	M an..3	M	*R	1 = Underlying business function	
4025 Business function, coded	M an..3	M		SAL= Salary payment	
1131 Code list qualifier	C an..3	O			
3055 Code list responsible agency, coded	C an..3	O			
4022 Business description	C an..70	O			
3279 Geographic environment, coded	C an..3	R	*	DO = Domestic	
			*	IN = International	
			*	DR = Domestic with regulatory information required	
			*	IR = International with regulatory information required	
			*	IS = European Union - ECBS Payments. See separate D6 MIG compliant with EBS-200 (ECBS).	
4487 Type of financial transaction, coded	C an..3	O	*R	1 = Clean payment	
C551 Bank operation	C	O		The usage of this composite is subject to national agreement.	
4383 Bank operation, coded	M an..3	M	*R	UGI = Urgent giro	
1131 Code list qualifier	C an..3	N			
3055 Code list responsible agency, coded	C an..3	N			
4463 Intra-company payment, coded	C an..3	O	*R	1 = Intracompany payment	
<u>Example:</u>					
BUS+1:SAL+IN'					

SG4 - 9999 LIN-DTM-RFF-BUS-FCA-SG5-SG6-SG7-SG8-SG9-SG10-SG11					
FCA - 1 Financial charges allocation					
UN/EDIFACT Directory 96.A C		D6 D		CRG N	
A segment specifying the method for allocation of charges and allowances (e.g. charges to be borne by the ordering customer), and identifying the ordering customer's account to which such charges or allowances should be directed where it is different from the principal account. This constitutes a default specification and may be overridden at detail level.		This segment is mutually exclusive with the FCA segment in level C.		Not used.	
Segment number : 17					
UN/EDIFACT Directory 96.A		D6 Description		CRG Description	
4471 Settlement, coded	M an..3	M	*	13 = All charges borne by payee (or beneficiary)	
			*	14 = Each pay own cost	
			*	15 = All charges borne by payor (or originator of PAYMUL)	
C878 Charge/allowance account	C	O		The usage of this composite is subject to bilateral agreement.	
3434 Institution branch number	M an..17	M		National identification of the financial institution in coded form.	
1131 Code list qualifier	C an..3	R	*	The allowed combinations of the codes of DE1131 and 3055 are stated in Section 1.5. of this MIG.	
3055 Code list responsible agency, coded	C an..3	R	*	The allowed combinations of the codes of DE1131 and 3055 are stated in Section 1.5. of this MIG.	
3194 Account holder number	C an..35	R			
6345 Currency, coded	C an..3	O		ISO 4217 three alpha currency code.	
<u>Example:</u>					
FCA+14'					

SG4 - 9999 LIN-DTM-RFF-BUS-FCA-SG5-SG6-SG7-SG8-SG9-SG10-SG11			
SG5 - 1 MOA-CUX-DTM-RFF			
UN/EDIFACT Directory 96.A C		D6 R	
A group of segments containing the currency of the single amounts in level C, currency to be transferred, plus the total of all single amounts of level C.			
MOA - 1 Monetary amount			
UN/EDIFACT Directory 96.A M		D6 M	
A segment specifying the total amount and the currency to be transferred.		The amount specified in this segment is the (batch) amount to be debited to the account identified in SG 6, and must be equal to the sum of (individual) amounts of the MOA segments in SG 11.	
Segment number : 18			
UN/EDIFACT Directory 96.A		D6 Description	
CRG Description			
C516 Monetary amount	M	M	
5025 Monetary amount type qualifier	M an..3	M *	9 = Amount due/amount payable
		M *	57 = Equivalent amount.
			The same code must be used in each MOA segment of SG11.
5004 Monetary amount	C n..18	R	The decimal separator is either a comma or a dot. No other delimiters, e.g., thousands separators, are allowed.
6345 Currency, coded	C an..3	R	ISO 4217 three alpha currency code.
			If code 57 is used in DE 5025, this DE contains the reference currency and the following CUX segment is required and contains the currency of the equivalent amount in the first occurrence of C504 and the currency of the amount to be transferred in the second occurrence of C504.
6343 Currency qualifier	C an..3	N	
4405 Status, coded	C an..3	N	
<u>Example:</u> MOA+9:23800,3:EUR'			

SG4 - 9999 LIN-DTM-RFF-BUS-FCA-SG5-SG6-SG7-SG8-SG9-SG10-SG11					
SG5 - 1 MOA-CUX-DTM-RFF					
CUX - 1 Currencies					
UN/EDIFACT Directory 96.A C		D6 D		CRG N	
A segment specifying the source currency and the destination currency of the transaction, when they are different. The rate of exchange is solely used when previously agreed between the ordering customer and the ordered bank.		This segment is used when code 57 (equivalent amount) is used in DE5025 of the preceding MOA segment to specify the currency to be transferred.		Not used.	
Segment number : 19					
UN/EDIFACT Directory 96.A		D6 Description		CRG Description	
C504 Currency details	C	R			
6347 Currency details qualifier	M an..3	M	*R	2 = Reference currency. This is the source currency in DE 6345 when qualified by code 57 in DE 5025, in the previous MOA segment.	
6345 Currency, coded	C an..3	R		ISO 4217 three alpha currency code.	
6343 Currency qualifier	C an..3	N			
6348 Currency rate base	C n..4	N			
C504 Currency details	C	R			
6347 Currency details qualifier	M an..3	M	*R	3 = Target currency. This is the currency of the amount to be transferred.	
6345 Currency, coded	C an..3	R		ISO 4217 three alpha currency code.	
6343 Currency qualifier	C an..3	N			
6348 Currency rate base	C n..4	N			
5402 Rate of exchange	C n..12	O			
6341 Currency market exchange, coded	C an..3	N			
<u>Example:</u> CUX+2:EUR+3:USD'					

SG4 - 9999 LIN-DTM-RFF-BUS-FCA-SG5-SG6-SG7-SG8-SG9-SG10-SG11					
SG5 - 1 MOA-CUX-DTM-RFF					
DTM - 2 Date/time/period					
UN/EDIFACT Directory 96.A C			D6 D		CRG N
A segment identifying the effective date and/or time the rate of exchange was fixed. The other occurrence identifies the reference date.			This segment is used when an exchange rate contract/deal number is given in the next RFF segment.		Not used.
Segment number : 20					
UN/EDIFACT Directory 96.A			D6 Description		CRG Description
C507	Date/time/period	M	M		
2005	Date/time/period qualifier	M an..3	M	*R	171 = Reference date/time. Usage of this segment requires the use of the following RFF segment.
2380	Date/time/period	C an..35	R		
2379	Date/time/period format qualifier	C an..3	R	*	102 = CCYYMMDD Code 102 is recommended.
				*	203 = CCYYMMDDHHMM
<u>Example:</u> DTM+171:19970630:102'					

SG4 - 9999 LIN-DTM-RFF-BUS-FCA-SG5-SG6-SG7-SG8-SG9-SG10-SG11					
SG5 - 1 MOA-CUX-DTM-RFF					
RFF - 1 Reference					
UN/EDIFACT Directory 96.A C		D6 D		CRG N	
A segment identifying the deal between ordered bank and ordering customer.		This segment is used when an exchange rate contract/deal number is to be given.		Not used.	
Segment number : 21					
UN/EDIFACT Directory 96.A		D6 Description		CRG Description	
C506 Reference	M	M			
1153 Reference qualifier	M an..3	M		ACX = Banker's acceptance	
1154 Reference number	C an..35	R		FX = Foreign exchange contract number	
1156 Line number	C an..6	N			
4000 Reference version number	C an..35	N			
<u>Example:</u>					
RFF+FX:407082'					

SG4 - 9999 LIN-DTM-RFF-BUS-FCA-SG5-SG6-SG7-SG8-SG9-SG10-SG11		
SG6 - 1 FII-CTA-COM		
UN/EDIFACT Directory 96.A M	D6 M	CRG M
A group of segments containing the account servicing bank including the account to be debited. If the ordering party is not quoted separately in the NAD-segment on level-B or level-A, then this group also contains the information of the ordering party.	A group of segments containing the ordered bank including the account to be debited. If the ordering party is not quoted separately in an NAD-segment, then this group must contain the information about the debtor.	
FII - 1 Financial institution information		
UN/EDIFACT Directory 96.A M	D6 M	CRG M
A segment identifying the financial institution and relevant account number with the currency.	This segment contains the ordered bank as well as at least the payor account identification.	Bank account definition varies with countries as it sometimes includes the national bank/branching sorting code and sometimes not, often leading to errors. The correct implementation is to have one single string. However for the time being it can be split if agreed nationally. Please also refer to CRG document with examples (available at http://cm.sfs.siemens.de/crg/migs/fii-seg.doc).
Segment number : 22		
UN/EDIFACT Directory 96.A	D6 Description	CRG Description
3035 Party qualifier M an..3	M *R OR = Ordered bank	
C078 Account identification C	R	
3194 Account holder number C an..35	R The account number should be entered according to the national account number scheme. If an IBAN is used, it should be present in this DE.	
3192 Account holder name C an..35	D Identifying the name and place of the account holder is mandatory in some countries. If the ordering customer is different to the account holder, the ordering customer is to be identified in the NAD segment of either B- or -C levels; the B- and C-levels are mutually exclusive in this case.	
3192 Account holder name C an..35	O The account holder name (continued).	
6345 Currency, coded C an..3	O The ISO 4217 three alpha currency code.	

C088 Institution identification	C	D		This composite DE is not needed in some countries. BIC codes are to be mapped into 3433 and national codes in 3434. They are not mutually exclusive, but the following priority rule should be followed: 1.- IBAN in 3194 2.- Bank account number in 3194 and national bank identification in 3434 / 1131 / 3055 3.- Bank account number in 3194 and international bank identification (BIC) in 3434 / 1131 / 3055 In case of contradiction, the definition with highest priority will be used.
3433 Institution name identification	C an..11	D		International identification of the financial institution in coded form.
1131 Code list qualifier	C an..3	D	*R	25 = Bank Identification
3055 Code list responsible agency, coded	C an..3	D	*R	5 = ISO (International Organization for Standardization)
3434 Institution branch number	C an..17	D		National identification of the financial institution in coded form
1131 Code list qualifier	C an..3	D	*	The allowed combinations of the codes of DE1131 and 3055 are stated in Section 1.5. of this MIG.
3055 Code list responsible agency, coded	C an..3	D	*	The allowed combinations of the codes of DE1131 and 3055 are stated in Section 1.5. of this MIG.
3432 Institution name	C an..70	N		
3436 Institution branch place	C an..70	N		
3207 Country, coded	C an..3	D		ISO 3166 two alpha country code. This DE must be used unless an IBAN is included in DE3194.
<u>Example:</u> FII+OR+78520739:J SCHMIDT:FRANKFURT +:::50080000:25:131+DE'				

SG4 - 9999 LIN-DTM-RFF-BUS-FCA-SG5-SG6-SG7-SG8-SG9-SG10-SG11			
SG6 - 1 FII-CTA-COM			
CTA - 1 Contact information			
UN/EDIFACT Directory 96.A C		D6 N	
A segment identifying a person or a department for the financial institution specified in the FII segment and to whom communication should be directed.		Not used.	
Segment number : 23			
UN/EDIFACT Directory 96.A		D6 Description	
3139 Contact function, coded	C an..3		
C056 Department or employee details	C		
3413 Department or employee identification	C an..17		
3412 Department or employee	C an..35		
		CRG Description	

SG4 - 9999 LIN-DTM-RFF-BUS-FCA-SG5-SG6-SG7-SG8-SG9-SG10-SG11					
SG6 - 1 FII-CTA-COM					
COM - 5 Communication contact					
UN/EDIFACT Directory 96.A C			D6 N		CRG N
A segment providing a communication number for the party identified in the FII segment.			Not used.		Not used.
Segment number : 24					
UN/EDIFACT Directory 96.A			D6 Description		CRG Description
C076	Communication contact	M			
3148	Communication number	M an..512			
3155	Communication channel qualifier	M an..3			

SG4 - 9999 LIN-DTM-RFF-BUS-FCA-SG5-SG6-SG7-SG8-SG9-SG10-SG11			
SG7 - 3 NAD-CTA-COM			
UN/EDIFACT Directory 96.A C		D6 O	
A group of segments identifying the ordering party mutually exclusive with NAD- segment on level-A for the ordering party (Ordering customer and payor). Furthermore, one contact party can also be quoted in this group.		This SG is to be used by bilateral agreement only.	
NAD - 1 Name and address		CRG N	
UN/EDIFACT Directory 96.A M		D6 M	
A segment identifying the name and address of the non-financial institutions associated with the PAYMUL.		This segment is mutually exclusive with the NAD segment of the same party qualifier in level C.	
CRG N		Not used.	
Segment number : 25			
UN/EDIFACT Directory 96.A		D6 Description	
CRG Description			
3035 Party qualifier	M an..3	M *	OY = Ordering customer PL = Payor For more information about dependencies, refer to Section 1.4. of this MIG.
C082 Party identification details	C	O	
3039 Party id. identification	M an..35	M	Coded identification of the identified party.
1131 Code list qualifier	C an..3	O	
3055 Code list responsible agency, coded	C an..3	O	
C058 Name and address	C	D	Either C058 or DEs C080, C059, 3164, 3229, 3251 and 3207 are used. Unstructured specification is not recommended.
3124 Name and address line	M an..35	M	
3124 Name and address line	C an..35	O	
3124 Name and address line	C an..35	O	
3124 Name and address line	C an..35	O	
3124 Name and address line	C an..35	O	
C080 Party name	C	D	Either C058 or DEs C080, C059, 3164, 3229, 3251 and 3207 are used.
3036 Party name	M an..35	M	
3036 Party name	C an..35	O	
3036 Party name	C an..35	O	
3036 Party name	C an..35	O	
3036 Party name	C an..35	O	

3045	Party name format, coded	C an..3	O		
C059	Street	C	D		
3042	Street and number/p.o. box	M an..35	M		
3042	Street and number/p.o. box	C an..35	O		
3042	Street and number/p.o. box	C an..35	O		
3042	Street and number/p.o. box	C an..35	O		
3164	City name	C an..35	D		
3229	Country sub-entity identification	C an..9	D		
3251	Postcode identification	C an..9	D		
3207	Country, coded	C an..3	D	Country of the identified party. ISO 3166 two alpha country code.	
<u>Example:</u>					
NAD+OY+2729712345832::9'					

SG4 - 9999 LIN-DTM-RFF-BUS-FCA-SG5-SG6-SG7-SG8-SG9-SG10-SG11					
SG7 - 3 NAD-CTA-COM					
CTA - 1 Contact information					
UN/EDIFACT Directory 96.A C			D6 O		CRG N
A segment identifying a person or a department for the party specified in the NAD segment and to whom communication should be directed.					Not used.
Segment number : 26					
UN/EDIFACT Directory 96.A			D6 Description		CRG Description
3139 Contact function, coded	C an..3	R	*R	IC = Information contact	
C056 Department or employee details	C	R			
3413 Department or employee identification	C an..17	N			
3412 Department or employee	C an..35	R		The name of the department or employee in free text form.	
<u>Example:</u>					
CTA+IC+:JIM JOHNSON'					

SG4 - 9999 LIN-DTM-RFF-BUS-FCA-SG5-SG6-SG7-SG8-SG9-SG10-SG11					
SG7 - 3 NAD-CTA-COM					
COM - 5 Communication contact					
UN/EDIFACT Directory 96.A C		D6 O		CRG N	
A segment providing a communication number for the party identified in the NAD segment and optionally for the contact identified in the associated CTA segment.				Not used.	
Segment number : 27					
UN/EDIFACT Directory 96.A		D6 Description		CRG Description	
C076 Communication contact	M	M			
3148 Communication number	M an..512	M			
3155 Communication channel qualifier	M an..3	M			
<u>Example:</u> COM+496926050:TE'					

SG4 - 9999 LIN-DTM-RFF-BUS-FCA-SG5-SG6-SG7-SG8-SG9-SG10-SG11			
SG8 - 1 INP-FTX-DTM			
UN/EDIFACT Directory 96.A C		D6 O	
A group of segments containing instructions from the ordering customer relating to parties identified in the NAD and FII segments.		The specifications of this SG can be determined nationally.	
CRG N			
Not used.			
INP - 1 Parties to instruction			
UN/EDIFACT Directory 96.A M		D6 M	
A segment identifying the party originating the instruction and the parties to be contacted. It specifies where appropriate the instruction in coded form.			
CRG N			
Not used.			
Segment number : 28			
UN/EDIFACT Directory 96.A		D6 Description	
CRG Description			
C849 Parties to instruction	C	O	
3301 Party enacting instruction identification	M an..17	M	
3285 Recipient of the instruction identification	C an..17	O	
C522 Instruction	C	O	
4403 Instruction qualifier	M an..3	M	
4401 Instruction, coded	C an..3	O	
1131 Code list qualifier	C an..3	O	
3055 Code list responsible agency, coded	C an..3	O	
4400 Instruction	C an..35	O	
C850 Status of instruction	C	O	
4405 Status, coded	M an..3	M	
3036 Party name	C an..35	O	
1229 Action request/notification, coded	C an..3	O	

SG4 - 9999 LIN-DTM-RFF-BUS-FCA-SG5-SG6-SG7-SG8-SG9-SG10-SG11					
SG8 - 1 INP-FTX-DTM					
FTX - 1 Free text					
UN/EDIFACT Directory 96.A C			D6 O		CRG N
A segment providing free text instruction relating to the associated INP segment.					Not used.
Segment number : 29					
UN/EDIFACT Directory 96.A			D6 Description		CRG Description
4451	Text subject qualifier	M an..3	M	*R	AAG = Party instructions
4453	Text function, coded	C an..3	O		
C107	Text reference	C	O		
4441	Free text, coded	M an..3	M		
1131	Code list qualifier	C an..3	O		
3055	Code list responsible agency, coded	C an..3	O		
C108	Text literal	C	O		
4440	Free text	M an..70	M		
4440	Free text	C an..70	O		
4440	Free text	C an..70	O		
4440	Free text	C an..70	O		
4440	Free text	C an..70	O		
3453	Language, coded	C an..3	O		

SG4 - 9999 LIN-DTM-RFF-BUS-FCA-SG5-SG6-SG7-SG8-SG9-SG10-SG11					
SG8 - 1 INP-FTX-DTM					
DTM - 2 Date/time/period					
UN/EDIFACT Directory 96.A C			D6 O		CRG N
A segment specifying the earliest and the latest dates and times by which the instruction specified in the INP and/or FTX segment(s) needs to be carried out.					Not used.
Segment number : 30					
UN/EDIFACT Directory 96.A			D6 Description		CRG Description
C507	Date/time/period	M	M		
2005	Date/time/period qualifier	M an..3	M		
2380	Date/time/period	C an..35	O		
2379	Date/time/period format qualifier	C an..3	O		

SG4 - 9999 LIN-DTM-RFF-BUS-FCA-SG5-SG6-SG7-SG8-SG9-SG10-SG11					
SG9 - 10 GIS-MOA-LOC-NAD-RCS-FTX					
UN/EDIFACT Directory 96.A C		D6 D		CRG N	
A group of segments providing information for subsequent use by regulatory authorities requiring statistical and other types of data.		The specifications of this SG are to be determined on unilateral regulatory reporting requirements. This SG is mutually exclusive with SG 15.		Not used.	
GIS - 1 General indicator					
UN/EDIFACT Directory 96.A M		D6 M		CRG N	
A segment identifying what processing should be completed by regulatory authorities.		The contents of this segment are to be determined nationally due to cross-border regulatory reporting or central bank requirements.		Not used.	
Segment number : 31					
UN/EDIFACT Directory 96.A		D6 Description		CRG Description	
C529 Processing indicator	M	M			
7365 Processing indicator, coded	M an..3	M			
1131 Code list qualifier	C an..3	O			
3055 Code list responsible agency, coded	C an..3	O			
7187 Process type identification	C an..17	O			

SG4 - 9999 LIN-DTM-RFF-BUS-FCA-SG5-SG6-SG7-SG8-SG9-SG10-SG11					
SG9 - 10 GIS-MOA-LOC-NAD-RCS-FTX					
MOA - 1 Monetary amount					
UN/EDIFACT Directory 96.A C			D6 O		CRG N
A segment giving the amount and the currency of each transaction to be reported.			The contents of this segment are to be determined nationally due to cross-border regulatory reporting or central bank requirements.		Not used.
Segment number : 32					
UN/EDIFACT Directory 96.A			D6 Description		CRG Description
C516 Monetary amount	M	M			
5025 Monetary amount type qualifier	M an..3	M			
5004 Monetary amount	C n..18	O			
6345 Currency, coded	C an..3	O			
6343 Currency qualifier	C an..3	O			
4405 Status, coded	C an..3	O			

SG4 - 9999 LIN-DTM-RFF-BUS-FCA-SG5-SG6-SG7-SG8-SG9-SG10-SG11			
SG9 - 10 GIS-MOA-LOC-NAD-RCS-FTX			
LOC - 2 Place/location identification			
UN/EDIFACT Directory 96.A C		D6 O	
A segment giving the different origins/destinations (places) of goods/investment/ services.		The contents of this segment are to be determined nationally due to cross-border regulatory reporting or central bank requirements.	
CRG N			
Not used.			
Segment number : 33			
UN/EDIFACT Directory 96.A		D6 Description	
		CRG Description	
3227 Place/location qualifier	M an..3	M	
C517 Location identification	C	O	
3225 Place/location identification	C an..25	O	
1131 Code list qualifier	C an..3	O	
3055 Code list responsible agency, coded	C an..3	O	
3224 Place/location	C an..70	O	
C519 Related location one identification	C	O	
3223 Related place/location one identification	C an..25	O	
1131 Code list qualifier	C an..3	O	
3055 Code list responsible agency, coded	C an..3	O	
3222 Related place/location one	C an..70	O	
C553 Related location two identification	C	O	
3233 Related place/location two identification	C an..25	O	
1131 Code list qualifier	C an..3	O	
3055 Code list responsible agency, coded	C an..3	O	
3232 Related place/location two	C an..70	O	
5479 Relation, coded	C an..3	O	

SG4 - 9999 LIN-DTM-RFF-BUS-FCA-SG5-SG6-SG7-SG8-SG9-SG10-SG11			
SG9 - 10 GIS-MOA-LOC-NAD-RCS-FTX			
NAD - 1 Name and address			
UN/EDIFACT Directory 96.A C		D6 O	
A segment identifying a party related to the associated informative text.		The contents of this segment are to be determined nationally due to cross-border regulatory reporting or central bank requirements.	
CRG N			
A segment identifying a party related to the associated informative text.			
The contents of this segment are to be determined nationally due to cross-border regulatory reporting or central bank requirements.			
Not used.			
Segment number : 34			
UN/EDIFACT Directory 96.A		D6 Description	
		CRG Description	
3035 Party qualifier	M an..3	M	
C082 Party identification details	C	O	
3039 Party id. identification	M an..35	M	
1131 Code list qualifier	C an..3	O	
3055 Code list responsible agency, coded	C an..3	O	
C058 Name and address	C	O	
3124 Name and address line	M an..35	M	
3124 Name and address line	C an..35	O	
3124 Name and address line	C an..35	O	
3124 Name and address line	C an..35	O	
3124 Name and address line	C an..35	O	
C080 Party name	C	O	
3036 Party name	M an..35	M	
3036 Party name	C an..35	O	
3036 Party name	C an..35	O	
3036 Party name	C an..35	O	
3036 Party name	C an..35	O	
3045 Party name format, coded	C an..3	O	
C059 Street	C	O	
3042 Street and number/p.o. box	M an..35	M	
3042 Street and number/p.o. box	C an..35	O	
3042 Street and number/p.o. box	C an..35	O	
3042 Street and number/p.o. box	C an..35	O	
3164 City name	C an..35	O	
3229 Country sub-entity identification	C an..9	O	
3251 Postcode identification	C an..9	O	

3207 Country, coded	C an..3	O	ISO 3166 two alpha country code.		
---------------------	---------	---	----------------------------------	--	--

SG4 - 9999 LIN-DTM-RFF-BUS-FCA-SG5-SG6-SG7-SG8-SG9-SG10-SG11			
SG9 - 10 GIS-MOA-LOC-NAD-RCS-FTX			
RCS - 1 Requirements and conditions			
UN/EDIFACT Directory 96.A C		D6 O	
A segment giving the nature (e.g. goods, transport services) and direction of each transaction to be recorded in coded form.		The contents of this segment are to be determined nationally due to cross-border regulatory reporting or central bank requirements.	
CRG N			
Not used.			
Segment number : 35			
UN/EDIFACT Directory 96.A		D6 Description	
CRG Description			
7293	Sector/subject identification qualifier	M an..3	M
C550	Requirement/condition identification	C	O
7295	Requirement/condition identification	M an..17	M
1131	Code list qualifier	C an..3	O
3055	Code list responsible agency, coded	C an..3	O
7294	Requirement or condition	C an..35	N
1229	Action request/notification, coded	C an..3	N

SG4 - 9999 LIN-DTM-RFF-BUS-FCA-SG5-SG6-SG7-SG8-SG9-SG10-SG11			
SG9 - 10 GIS-MOA-LOC-NAD-RCS-FTX			
FTX - 10 Free text			
UN/EDIFACT Directory 96.A C		D6 O	
A segment giving information in coded or in clear form to provide information relevant to regulatory authorities requirements.		The contents of this segment are to be determined nationally due to cross-border regulatory reporting or central bank requirements.	
CRG N			
Not used.			
Segment number : 36			
UN/EDIFACT Directory 96.A		D6 Description	
		CRG Description	
4451	Text subject qualifier	M an..3	M
4453	Text function, coded	C an..3	O
C107	Text reference	C	O
4441	Free text, coded	M an..3	M
1131	Code list qualifier	C an..3	O
3055	Code list responsible agency, coded	C an..3	O
C108	Text literal	C	O
4440	Free text	M an..70	M
4440	Free text	C an..70	O
4440	Free text	C an..70	O
4440	Free text	C an..70	O
4440	Free text	C an..70	O
3453	Language, coded	C an..3	O

SG4 - 9999 LIN-DTM-RFF-BUS-FCA-SG5-SG6-SG7-SG8-SG9-SG10-SG11				
SG10 - 1 PRC-FTX				
UN/EDIFACT Directory 96.A C		D6 D		CRG N
A group of segments - mutually exclusive with level -C- containing the details of payment, which are determined for all payments on level C.		The content of details of payment will be passed on to the beneficiary and will be added to each single transaction contained in all C-levels related to this occurrence of B-level. It is recommended that PRC SG be used in level-C for this purpose. This group is mutually exclusive with the PRC group in Level C.		Not used.
PRC - 1 Process identification				
UN/EDIFACT Directory 96.A M		D6 M		CRG N
A segment identifying the kind of free text following this segment.		This segment is also used as a trigger segment for group 10.		Not used.
Segment number : 37				
UN/EDIFACT Directory 96.A		D6 Description		CRG Description
C242 Process type and description	M	M		
7187 Process type identification	M an..17	M	*R	11 = Processing of unstructured information - only the FTX segment must follow.
1131 Code list qualifier	C an..3	N		
3055 Code list responsible agency, coded	C an..3	N		
7186 Process type	C an..35	N		
7186 Process type	C an..35	N		
<u>Example:</u> PRC+11'				

SG4 - 9999 LIN-DTM-RFF-BUS-FCA-SG5-SG6-SG7-SG8-SG9-SG10-SG11						
SG10 - 1 PRC-FTX						
FTX - 1 Free text						
UN/EDIFACT Directory 96.A M			D6 M		CRG N	
A segment for information in coded or in clear form to provide information from the ordering customer to the beneficiary.			Specification of details of payment in free form, from the ordering customer to the beneficiary. This information is applicable to all subsequent transactions in the C-level.		Not used.	
Segment number : 38						
UN/EDIFACT Directory 96.A			D6 Description		CRG Description	
4451	Text subject qualifier	M an..3	M	*R	PMD = Payment detail/remittance information	
4453	Text function, coded	C an..3	N			
C107	Text reference	C	N			
4441	Free text, coded	M an..3				
1131	Code list qualifier	C an..3				
3055	Code list responsible agency, coded	C an..3				
C108	Text literal	C	R			
4440	Free text	M an..70	M			
4440	Free text	C an..70	O			
4440	Free text	C an..70	O			
4440	Free text	C an..70	O			
4440	Free text	C an..70	O			
3453	Language, coded	C an..3	O			
<u>Example:</u>						
FTX+PMD+++SALARY DUE'						

SG4 - 9999 LIN-DTM-RFF-BUS-FCA-SG5-SG6-SG7-SG8-SG9-SG10-SG11			
SG11 - 9999 SEQ-MOA-DTM-RFF-PAI-FCA-SG12-SG13-SG14-SG15-SG16			
UN/EDIFACT Directory 96.A M		D6 M	
This segment group contains information regarding the Beneficiaries of the payments. Certain payment details may be provided either in segment group 11 or in segment group 4, but not in both.		This SG contains information about the individual payment transaction of the B-level. Certain payment details may be provided either in SG 4 or in SG 11, but not in both. Please refer to the SG description of SG4.	
SEQ - 1 Sequence details			
UN/EDIFACT Directory 96.A M		D6 M	
A segment identifying the beginning of the credit side of the transaction (C level) by a sequential number, which may also be used for reconciliation purposes.		This is a trigger segment specifying the start of each single transaction.	
Segment number : 39			
UN/EDIFACT Directory 96.A		D6 Description	
1245 Status indicator, coded	C an..3	N	Application generated number of the count of the sequence in a multiple payment order. The sequence number must be reset to one for each occurrence of a new line number (in LIN segment).
C286 Sequence information	C	R	
1050 Sequence number	M an..6	M	
1159 Sequence number source, coded	C an..3	N	
1131 Code list qualifier	C an..3	N	
3055 Code list responsible agency, coded	C an..3	N	
<u>Example:</u> SEQ++1'			

SG4 - 9999 LIN-DTM-RFF-BUS-FCA-SG5-SG6-SG7-SG8-SG9-SG10-SG11					
SG11 - 9999 SEQ-MOA-DTM-RFF-PAI-FCA-SG12-SG13-SG14-SG15-SG16					
MOA - 1 Monetary amount					
UN/EDIFACT Directory 96.A M		D6 M		CRG M	
A segment giving the amount value of the payment. It is the amount to be transferred. The currency is quoted on the debit side of the transaction (level B).		A segment identifying the amount of the payment. If it is an equivalent amount the payment currency is quoted in the CUX segment on B-level.			
Segment number : 40					
UN/EDIFACT Directory 96.A		D6 Description		CRG Description	
C516 Monetary amount	M	M			
5025 Monetary amount type qualifier	M an..3	M	* *	9 = Amount due/amount payable 57 = Equivalent amount The codes used in levels B and C must be identical; a mixture of codes 9 and 57 is not permitted.	* Use only 9 = Amount due/amount payable
5004 Monetary amount	C n..18	R		The decimal separator is a comma, unless agreed otherwise bilaterally.	
6345 Currency, coded	C an..3	R		ISO 4217 currency code This DE must be identical to the currency quoted in DE 6345 of the MOA segment in SG 5 (on B-level).	
6343 Currency qualifier	C an..3	N			
4405 Status, coded	C an..3	N			
<u>Example:</u> MOA+9:23800:USD'					

SG4 - 9999 LIN-DTM-RFF-BUS-FCA-SG5-SG6-SG7-SG8-SG9-SG10-SG11					
SG11 - 9999 SEQ-MOA-DTM-RFF-PAI-FCA-SG12-SG13-SG14-SG15-SG16					
DTM - 1 Date/time/period					
UN/EDIFACT Directory 96.A C			D6 O		CRG O
A segment identifying date(s)/time(s) related to the beneficiary's side.			Usage due to national law and practice.		
Segment number : 41					
UN/EDIFACT Directory 96.A			D6 Description		CRG Description
C507 Date/time/period	M	M			
2005 Date/time/period qualifier	M an..3	M	*	140 = Payment due date - not binding for the ordered bank. Preferred beneficiary's bank value date (if possible). Beneficiary's bank value date means the date on which the beneficiary's bank can dispose of the funds.	
			*	227 = Beneficiary's banks due date - binding for the ordered bank Requested beneficiary's bank value date. The ordering bank must ensure that the funds are at the beneficiary's bank at that date. The financial institution will conform to this date on a best effort basis.	
2380 Date/time/period	C an..35	R			
2379 Date/time/period format qualifier	C an..3	R	*R	102 = CCYYMMDD	
<u>Example:</u> DTM+140:20000103:102'					

SG4 - 9999 LIN-DTM-RFF-BUS-FCA-SG5-SG6-SG7-SG8-SG9-SG10-SG11					
SG11 - 9999 SEQ-MOA-DTM-RFF-PAI-FCA-SG12-SG13-SG14-SG15-SG16					
RFF - 3 Reference					
UN/EDIFACT Directory 96.A C		D6 R		CRG R	
A segment identifying a transaction from the ordering customer to the beneficiary and/ or from the ordering customer to the ordered bank.		A segment identifying the reference number of this transaction between the ordering customer and the ordered bank. The segment can furthermore identify payment references between the ordering customer and the beneficiary.			
Segment number : 42					
UN/EDIFACT Directory 96.A		D6 Description		CRG Description	
C506 Reference	M	M			
1153 Reference qualifier	M an..3	M	R	CR = Customer reference number - this mandatory reference number is used for reconciliation between the ordering customer and its bank. RA = Remittance advice number - the reference number of a separately sent message, a remittance advice, which contains the details of payment PQ = Payment reference - This customer to customer reference is not the remittance advice number. Codes RA and PQ are mutually exclusive and are passed through the banking chain.	
1154 Reference number	C an..35		R		
1156 Line number	C an..6		N		
4000 Reference version number	C an..35		N		
<u>Example:</u> RFF+CR:379802'					

SG4 - 9999 LIN-DTM-RFF-BUS-FCA-SG5-SG6-SG7-SG8-SG9-SG10-SG11					
SG11 - 9999 SEQ-MOA-DTM-RFF-PAI-FCA-SG12-SG13-SG14-SG15-SG16					
PAI - 1 Payment instructions					
UN/EDIFACT Directory 96.A C			D6 O		CRG O
A segment specifying the conditions, method and channel of payment for the payment order.			This segment must be used according to nationally agreed standards only.		
Segment number : 43					
UN/EDIFACT Directory 96.A			D6 Description		CRG Description
C534	Payment instruction details	M	M	Method of payment and payment channel.	
4439	Payment conditions, coded	C an..3	O		
4431	Payment guarantee, coded	C an..3	O		
4461	Payment means, coded	C an..3	O	For urgent payments this DE should be used. When nationally agreed codes are present, DE 1131 and DE 3055 must follow.	Use only codes: * 20 = Cheque * 21 = Banker's draft * ZA8 = Urgent commercial payment * ZA9 = Urgent treasury payment
1131	Code list qualifier	C an..3	O		
3055	Code list responsible agency, coded	C an..3	O		
4435	Payment channel, coded	C an..3	O		
<u>Example:</u>					
PAI+::8:::5'					

SG4 - 9999 LIN-DTM-RFF-BUS-FCA-SG5-SG6-SG7-SG8-SG9-SG10-SG11			
SG11 - 9999 SEQ-MOA-DTM-RFF-PAI-FCA-SG12-SG13-SG14-SG15-SG16			
FCA - 1 Financial charges allocation			
UN/EDIFACT Directory 96.A C		D6 D	
A segment specifying the method for allocation of charges and allowances and identifying the ordering customer's account to which such charges or allowances should be directed where it is different from the principal amount. This segment is mutually exclusive with the FCA segment in Segment Group 4.		This segment is mutually exclusive with the FCA segment in level B.	
Segment number : 44			
UN/EDIFACT Directory 96.A		D6 Description	
CRG Description			
4471 Settlement, coded	M an..3	M	* 13 = All charges borne by payee (or beneficiary) * 14 = Each pay own cost * 15 = All charges borne by payor (or ordering customer)
C878 Charge/allowance account	C	O	The usage of this composite is subject to bilateral agreement.
3434 Institution branch number	M an..17	M	National identification of the financial institution in coded form.
1131 Code list qualifier	C an..3	R	* The allowed combinations of the codes of DE1131 and 3055 are stated in Section 1.5. of this MIG.
3055 Code list responsible agency, coded	C an..3	R	* The allowed combinations of the codes of DE1131 and 3055 are stated in Section 1.5. of this MIG.
3194 Account holder number	C an..35	R	
6345 Currency, coded	C an..3	O	ISO 4217 three alpha currency code.
<u>Example:</u> FCA+14'			

SG4 - 9999 LIN-DTM-RFF-BUS-FCA-SG5-SG6-SG7-SG8-SG9-SG10-SG11			
SG11 - 9999 SEQ-MOA-DTM-RFF-PAI-FCA-SG12-SG13-SG14-SG15-SG16			
SG12 - 3 FII-CTA-COM			
UN/EDIFACT Directory 96.A C	D6	D	CRG D
A group of segments containing the beneficiary's bank and the account and if necessary up to two intermediary banks.	If no sufficient bank information is available, a fully qualified SG 13 – NAD segment must be used.		
FII - 1 Financial institution information			
UN/EDIFACT Directory 96.A M	D6	M	CRG M
A segment identifying the financial institution and relevant account number with the currency.	A segment containing the account servicing bank including the account to be credited and other necessary bank information.		Bank account definition varies with countries as it sometimes includes the national bank/branching sorting code and sometimes not, often leading to errors. The correct implementation is to have one single string. However for the time being it can be split if agreed nationally. Please also refer to CRG document with examples (available at http://cm.sfs.siemens.de/crg/migs/fii-seg.doc).
Segment number : 45			
UN/EDIFACT Directory 96.A		D6 Description	
CRG Description			
3035 Party qualifier	M an..3	M	* BF = Beneficiary's bank * BQ = Cheque drawn bank * I1 = Intermediary bank - this financial institution acts as a receiver of funds for the beneficiary's bank. For more information about dependencies, refer to Section 1.4. of this MIG.
C078 Account identification	C	O	
3194 Account holder number	C an..35	R	The account number should be entered according to the national account number scheme. If an IBAN is used, it should be present in this DE.
3192 Account holder name	C an..35	D	Identifying the name and place of the account holder is mandatory in some countries. For more information about dependencies, refer to Section 1.4. of this MIG.
3192 Account holder name	C an..35	O	The account holder name (continued).
6345 Currency, coded	C an..3	O	ISO 4217 three alpha currency code if needed

C088 Institution identification	C	D	
			<p>This composite DE is not needed in some countries .</p> <p>BIC codes are to be mapped into 3433 and national codes in 3434. They should not be mutually exclusive, but the following priority rule should be followed:</p> <p>1.- IBAN in 3194</p> <p>2a.- For domestic payments: Bank account number in 3194 and national bank identification in 3434 / 1131 / 3055</p> <p>2b.- For international payments: Bank account number in 3194 and international bank identification (BIC) in 3434 / 1131 / 3055</p> <p>3a.- For domestic payments: Bank account number in 3194 and international bank identification (BIC) in 3434 / 1131 / 3055</p> <p>3b.- For international payments: Bank account number in 3194 and national bank identification in 3434 / 1131 / 3055</p> <p>4. Address in 3432, 3436 and country code in 3207.</p> <p>In case of contradiction, the definition with highest priority will be used.</p>
3433 Institution name identification	C an..11	D	International identification of the financial institution in coded form.
1131 Code list qualifier	C an..3	D	*R 25 = Bank Identification
3055 Code list responsible agency, coded	C an..3	D	*R 5 = ISO (International Organization for Standardization)
3434 Institution branch number	C an..17	D	National identification of the financial institution in coded form.
1131 Code list qualifier	C an..3	D	* The allowed combinations of the codes of DE1131 and 3055 are stated in Section 1.5. of this MIG.
3055 Code list responsible agency, coded	C an..3	D	* The allowed combinations of the codes of DE1131 and 3055 are stated in Section 1.5. of this MIG.
3432 Institution name	C an..70	O	
3436 Institution branch place	C an..70	O	

3207 Country, coded	C an..3	D	ISO 3166 two alpha country code. This DE must be used unless an IBAN is included in DE3194.
----------------------------	---------	---	---

Example:

FII+BF+27834895:J SCHMIDT:FRANKFURT+DRESDEFF:25:5+DE'

SG4 - 9999 LIN-DTM-RFF-BUS-FCA-SG5-SG6-SG7-SG8-SG9-SG10-SG11			
SG11 - 9999 SEQ-MOA-DTM-RFF-PAI-FCA-SG12-SG13-SG14-SG15-SG16			
SG12 - 3 FII-CTA-COM			
CTA - 1 Contact information			
UN/EDIFACT Directory 96.A C		D6 N	CRG N
A segment identifying a person or a department for the financial institution specified in the FII segment and to whom communication should be directed.		Not used.	Not used.
Segment number : 46			
UN/EDIFACT Directory 96.A		D6 Description	CRG Description
3139 Contact function, coded	C an..3		
C056 Department or employee details	C		
3413 Department or employee identification	C an..17		
3412 Department or employee	C an..35		

SG4 - 9999 LIN-DTM-RFF-BUS-FCA-SG5-SG6-SG7-SG8-SG9-SG10-SG11			
SG11 - 9999 SEQ-MOA-DTM-RFF-PAI-FCA-SG12-SG13-SG14-SG15-SG16			
SG12 - 3 FII-CTA-COM			
COM - 5 Communication contact			
UN/EDIFACT Directory 96.A C		D6 N	
UN/EDIFACT Directory 96.A C		CRG N	
A segment providing a communication number for the party identified in the FII Segment and optionally for the intermediary banks.		Not used.	
Segment number : 47			
UN/EDIFACT Directory 96.A		D6 Description	
UN/EDIFACT Directory 96.A		CRG Description	
C076	Communication contact	M	
3148	Communication number	M an..512	
3155	Communication channel qualifier	M an..3	

3124	Name and address line	C	an..35	O	
3124	Name and address line	C	an..35	O	
3124	Name and address line	C	an..35	O	
C080	Party name	C		D	Either C058 or DEs C080, C059, 3164, 3229, 3251 and 3207 are used.
3036	Party name	M	an..35	M	
3036	Party name	C	an..35	O	
3036	Party name	C	an..35	O	
3036	Party name	C	an..35	O	
3036	Party name	C	an..35	O	
3045	Party name format, coded	C	an..3	O	
C059	Street	C		D	
3042	Street and number/p.o. box	M	an..35	M	
3042	Street and number/p.o. box	C	an..35	O	
3042	Street and number/p.o. box	C	an..35	O	
3042	Street and number/p.o. box	C	an..35	O	
3164	City name	C	an..35	D	
3229	Country sub-entity identification	C	an..9	D	
3251	Postcode identification	C	an..9	D	
3207	Country, coded	C	an..3	D	Country of the identified party. ISO 3166 two alpha country code.
<u>Example:</u>					
NAD+PE+++BENETTON++MILANO++IT'					

SG4 - 9999 LIN-DTM-RFF-BUS-FCA-SG5-SG6-SG7-SG8-SG9-SG10-SG11					
SG11 - 9999 SEQ-MOA-DTM-RFF-PAI-FCA-SG12-SG13-SG14-SG15-SG16					
SG13 - 3 NAD-CTA-COM					
CTA - 1 Contact information					
UN/EDIFACT Directory 96.A C			D6 O		CRG O
A segment identifying a person or a department for the party specified in the NAD segment and to whom communication should be directed.					
Segment number : 49					
UN/EDIFACT Directory 96.A			D6 Description		CRG Description
3139 Contact function, coded	C an..3	R	*R		IC = Information contact
C056 Department or employee details	C	R			
3413 Department or employee identification	C an..17	N			
3412 Department or employee	C an..35	R			Name of the department or employee in free text form.
<u>Example:</u> CTA+IC+:J BROWN'					

SG4 - 9999 LIN-DTM-RFF-BUS-FCA-SG5-SG6-SG7-SG8-SG9-SG10-SG11			
SG11 - 9999 SEQ-MOA-DTM-RFF-PAI-FCA-SG12-SG13-SG14-SG15-SG16			
SG13 - 3 NAD-CTA-COM			
COM - 5 Communication contact			
UN/EDIFACT Directory 96.A C		D6 O	
A segment providing a communication number for the party identified in the NAD segment and optionally for the contact identified in the associated CTA segment.			
Segment number : 50			
UN/EDIFACT Directory 96.A		D6 Description	
		CRG Description	
C076 Communication contact	M	M	
3148 Communication number	M an..512	M	When character sets UNOA or UNOB are used, the @ in e-mail addresses must be shown with (at) (parenthesis, at, parenthesis), e.g. <john.smith(at)abc.com>.
3155 Communication channel qualifier	M an..3	M	
<u>Example:</u>			
COM+12127783894:TE'			

SG4 - 9999 LIN-DTM-RFF-BUS-FCA-SG5-SG6-SG7-SG8-SG9-SG10-SG11			
SG11 - 9999 SEQ-MOA-DTM-RFF-PAI-FCA-SG12-SG13-SG14-SG15-SG16			
SG14 - 3 INP-FTX-DTM			
UN/EDIFACT Directory 96.A C	D6	O	CRG N
A group of segments containing instructions from the ordering customer relating to parties identified in the NAD and FII segments. It specifies action to be taken by the identified parties and the date (and optionally time) by which such action needs to be taken.			Not used.
INP - 1 Parties to instruction			
UN/EDIFACT Directory 96.A M	D6	M	CRG N
A segment identifying the party originating the instruction and the parties to be contacted. It specifies where appropriate the instruction in coded form.			Not used.
Segment number : 51			
UN/EDIFACT Directory 96.A	D6 Description		CRG Description
C849 Parties to instruction	C	R	
3301 Party enacting instruction identification	M an..17	M *	3 = Beneficiary's bank
		M *	YC7 = Ordered bank (D6 code)
3285 Recipient of the instruction identification	C an..17	D *R	11 = Creditor. Use of code 11 depends on the instruction.
C522 Instruction	C	O	
4403 Instruction qualifier	M an..3	M *R	2 = Party instructions
4401 Instruction, coded	C an..3	R	
1131 Code list qualifier	C an..3	N	
3055 Code list responsible agency, coded	C an..3	N	
4400 Instruction	C an..35	N	
C850 Status of instruction	C	N	
4405 Status, coded	M an..3		
3036 Party name	C an..35		
1229 Action request/notification, coded	C an..3	N	
<u>Example:</u>			
INP+3:11+2:AP'			

SG4 - 9999 LIN-DTM-RFF-BUS-FCA-SG5-SG6-SG7-SG8-SG9-SG10-SG11						
SG11 - 9999 SEQ-MOA-DTM-RFF-PAI-FCA-SG12-SG13-SG14-SG15-SG16						
SG14 - 3 INP-FTX-DTM						
FTX - 1 Free text						
UN/EDIFACT Directory 96.A C			D6 O		CRG N	
A segment providing free text instruction relating to the associated INP segment.			The use of this segment will prevent automated processing of the message.		Not used.	
Segment number : 52						
UN/EDIFACT Directory 96.A			D6 Description		CRG Description	
4451	Text subject qualifier	Man..3	M	*R	AAG = Party instructions	
4453	Text function, coded	C an..3	N			
C107	Text reference	C	N			
4441	Free text, coded	Man..3				
1131	Code list qualifier	C an..3				
3055	Code list responsible agency, coded	C an..3				
C108	Text literal	C	R			
4440	Free text	Man..70	M			
4440	Free text	C an..70	O			
4440	Free text	C an..70	O			
4440	Free text	C an..70	O			
4440	Free text	C an..70	O			
3453	Language, coded	C an..3	O			
<u>Example:</u>						
FTX+AAG+++EMBARGO RESTRICTIONS IN FORCE+EN'						

SG4 - 9999 LIN-DTM-RFF-BUS-FCA-SG5-SG6-SG7-SG8-SG9-SG10-SG11			
SG11 - 9999 SEQ-MOA-DTM-RFF-PAI-FCA-SG12-SG13-SG14-SG15-SG16			
SG14 - 3 INP-FTX-DTM			
DTM - 2 Date/time/period			
UN/EDIFACT Directory 96.A C		D6 O	
A segment specifying the earliest and the latest dates and times by which the instruction specified in the INP and/or FTX segment(s) needs to be carried out.		CRG N	
		Not used.	
Segment number : 53			
UN/EDIFACT Directory 96.A		D6 Description	
CRG Description			
C507 Date/time/period	M	M	
2005 Date/time/period qualifier	M an..3	M *	174 = Advise after date/time - this is the earliest date/time to advise
		M *	175 = Advise before date/time - this is the latest date/time to advise
		M *	176 = Advise completed date/time
		M *	177 = Advise on date/time
2380 Date/time/period	C an..35	R	
2379 Date/time/period format qualifier	C an..3	R *	102 = CCYYMMDD
		R *	203 = CCYYMMDDHHMM
<u>Example:</u>			
DTM+174:200001031130:203'			

SG4 - 9999 LIN-DTM-RFF-BUS-FCA-SG5-SG6-SG7-SG8-SG9-SG10-SG11			
SG11 - 9999 SEQ-MOA-DTM-RFF-PAI-FCA-SG12-SG13-SG14-SG15-SG16			
SG15 - 10 GIS-MOA-LOC-NAD-RCS-FTX			
UN/EDIFACT Directory 96.A C		D6 D	
A group of segments providing information for subsequent use by regulatory authorities requiring statistical and other types of data. It also identifies the regulatory authority for which the information is intended followed by the information itself.		The specifications of this SG are to be determined on unilateral regulatory reporting requirements. This SG is mutually exclusive with SG9.	
GIS - 1 General indicator			
UN/EDIFACT Directory 96.A M		D6 M	
A segment identifying what processing should be completed by regulatory authorities.		The contents of this segment are to be determined nationally due to cross-border regulatory reporting or central bank requirements.	
Segment number : 54			
UN/EDIFACT Directory 96.A		D6 Description	
C529 Processing indicator		M	M
7365 Processing indicator, coded	M an..3	M	
1131 Code list qualifier	C an..3	O	
3055 Code list responsible agency, coded	C an..3	O	
7187 Process type identification	C an..17	O	
		CRG Description	

SG4 - 9999 LIN-DTM-RFF-BUS-FCA-SG5-SG6-SG7-SG8-SG9-SG10-SG11			
SG11 - 9999 SEQ-MOA-DTM-RFF-PAI-FCA-SG12-SG13-SG14-SG15-SG16			
SG15 - 10 GIS-MOA-LOC-NAD-RCS-FTX			
MOA - 1 Monetary amount			
UN/EDIFACT Directory 96.A C		D6 O	
A segment giving the amount and the currency of each transaction to be reported.		The contents of this segment are to be determined nationally due to cross-border regulatory reporting or central bank requirements.	
Segment number : 55			
UN/EDIFACT Directory 96.A		D6 Description	
C516 Monetary amount		M	M
5025 Monetary amount type qualifier	M an..3	M	
5004 Monetary amount	C n..18	O	
6345 Currency, coded	C an..3	O	
6343 Currency qualifier	C an..3	O	
4405 Status, coded	C an..3	O	
		CRG Description	

SG4 - 9999 LIN-DTM-RFF-BUS-FCA-SG5-SG6-SG7-SG8-SG9-SG10-SG11			
SG11 - 9999 SEQ-MOA-DTM-RFF-PAI-FCA-SG12-SG13-SG14-SG15-SG16			
SG15 - 10 GIS-MOA-LOC-NAD-RCS-FTX			
LOC - 2 Place/location identification			
UN/EDIFACT Directory 96.A C		D6 O	CRG O
A segment giving the different origins/destinations (places) of goods/investment/ services.		The contents of this segment are to be determined nationally due to cross-border regulatory reporting or central bank requirements.	
Segment number : 56			
UN/EDIFACT Directory 96.A		D6 Description	CRG Description
3227	Place/location qualifier	Man..3 M	
C517	Location identification	C O	
3225	Place/location identification	C an..25 O	
1131	Code list qualifier	C an..3 O	
3055	Code list responsible agency, coded	C an..3 O	
3224	Place/location	C an..70 O	
C519	Related location one identification	C O	
3223	Related place/location one identification	C an..25 O	
1131	Code list qualifier	C an..3 O	
3055	Code list responsible agency, coded	C an..3 O	
3222	Related place/location one	C an..70 O	
C553	Related location two identification	C O	
3233	Related place/location two identification	C an..25 O	
1131	Code list qualifier	C an..3 O	
3055	Code list responsible agency, coded	C an..3 O	
3232	Related place/location two	C an..70 O	
5479	Relation, coded	C an..3 O	

SG4 - 9999 LIN-DTM-RFF-BUS-FCA-SG5-SG6-SG7-SG8-SG9-SG10-SG11			
SG11 - 9999 SEQ-MOA-DTM-RFF-PAI-FCA-SG12-SG13-SG14-SG15-SG16			
SG15 - 10 GIS-MOA-LOC-NAD-RCS-FTX			
NAD - 1 Name and address			
UN/EDIFACT Directory 96.A C		D6 O	
A segment identifying the recipient of the associated informative text.		The contents of this segment are to be determined nationally due to cross-border regulatory reporting or central bank requirements.	
Segment number : 57			
UN/EDIFACT Directory 96.A		D6 Description	
		CRG Description	
3035 Party qualifier	M an..3	M	
C082 Party identification details	C	O	
3039 Party id. identification	M an..35	M	
1131 Code list qualifier	C an..3	O	
3055 Code list responsible agency, coded	C an..3	O	
C058 Name and address	C	O	
3124 Name and address line	M an..35	M	
3124 Name and address line	C an..35	O	
3124 Name and address line	C an..35	O	
3124 Name and address line	C an..35	O	
3124 Name and address line	C an..35	O	
C080 Party name	C	O	
3036 Party name	M an..35	M	
3036 Party name	C an..35	O	
3036 Party name	C an..35	O	
3036 Party name	C an..35	O	
3036 Party name	C an..35	O	
3045 Party name format, coded	C an..3	O	
C059 Street	C	O	
3042 Street and number/p.o. box	M an..35	M	
3042 Street and number/p.o. box	C an..35	O	
3042 Street and number/p.o. box	C an..35	O	
3042 Street and number/p.o. box	C an..35	O	
3164 City name	C an..35	O	
3229 Country sub-entity identification	C an..9	O	

3251	Postcode identification	C an..9	O			
3207	Country, coded	C an..3	O	ISO 3166 two alpha country code.		

SG4 - 9999 LIN-DTM-RFF-BUS-FCA-SG5-SG6-SG7-SG8-SG9-SG10-SG11			
SG11 - 9999 SEQ-MOA-DTM-RFF-PAI-FCA-SG12-SG13-SG14-SG15-SG16			
SG15 - 10 GIS-MOA-LOC-NAD-RCS-FTX			
RCS - 1 Requirements and conditions			
UN/EDIFACT Directory 96.A C		D6 O	
A segment giving the nature (e.g. goods, transport services) and direction of each transaction to be recorded in coded form.		The contents of this segment are to be determined nationally due to cross-border regulatory reporting or central bank requirements.	
Segment number : 58			
UN/EDIFACT Directory 96.A		D6 Description	
7293	Sector/subject identification qualifier	M an..3	M
C550	Requirement/condition identification	C	O
7295	Requirement/condition identification	M an..17	M
1131	Code list qualifier	C an..3	O
3055	Code list responsible agency, coded	C an..3	O
7294	Requirement or condition	C an..35	O
1229	Action request/notification, coded	C an..3	O
UN/EDIFACT Directory 96.A		CRG Description	

SG4 - 9999 LIN-DTM-RFF-BUS-FCA-SG5-SG6-SG7-SG8-SG9-SG10-SG11			
SG11 - 9999 SEQ-MOA-DTM-RFF-PAI-FCA-SG12-SG13-SG14-SG15-SG16			
SG15 - 10 GIS-MOA-LOC-NAD-RCS-FTX			
FTX - 10 Free text			
UN/EDIFACT Directory 96.A C		D6 O	
A segment giving information in coded or in clear form to provide information relevant to regulatory authorities' requirements.		The contents of this segment are to be determined nationally due to cross-border regulatory reporting or central bank requirements.	
Segment number : 59			
UN/EDIFACT Directory 96.A		D6 Description	
		CRG Description	
4451	Text subject qualifier	M an..3	M
4453	Text function, coded	C an..3	O
C107	Text reference	C	O
4441	Free text, coded	M an..3	M
1131	Code list qualifier	C an..3	O
3055	Code list responsible agency, coded	C an..3	O
C108	Text literal	C	O
4440	Free text	M an..70	M
4440	Free text	C an..70	O
4440	Free text	C an..70	O
4440	Free text	C an..70	O
4440	Free text	C an..70	O
3453	Language, coded	C an..3	O

SG4 - 9999 LIN-DTM-RFF-BUS-FCA-SG5-SG6-SG7-SG8-SG9-SG10-SG11			
SG11 - 9999 SEQ-MOA-DTM-RFF-PAI-FCA-SG12-SG13-SG14-SG15-SG16			
SG16 - 1 PRC-FTX-SG17-SG23			
UN/EDIFACT Directory 96.A C		D6 D	
A group of segments containing the details of payment.		The content of details of payment will be passed on to the beneficiary. This group is mutually exclusive with the PRC group in Level B.	
PRC - 1 Process identification			
UN/EDIFACT Directory 96.A M		D6 M	
A segment identifying the kind of payment details.		This segment is also used as a trigger segment for group 16.	
Segment number : 60			
UN/EDIFACT Directory 96.A		D6 Description	
C242 Process type and description	M	M	
7187 Process type identification	M an..17	M	* 8 = Processing of structured information - only the DOC segment group must follow. * 9 = Processing of identical information in structured and unstructured form - the DOC segment group and FTX segment must follow. * 10 = Processing of different information in structured and unstructured form - the DOC segment group and FTX segment must follow. * 11 = Processing of unstructured information - only the FTX segment must follow.
1131 Code list qualifier	C an..3	N	
3055 Code list responsible agency, coded	C an..3	N	
7186 Process type	C an..35	N	
7186 Process type	C an..35	N	
<u>Example:</u> PRC+8'			

SG4 - 9999 LIN-DTM-RFF-BUS-FCA-SG5-SG6-SG7-SG8-SG9-SG10-SG11				
SG11 - 9999 SEQ-MOA-DTM-RFF-PAI-FCA-SG12-SG13-SG14-SG15-SG16				
SG16 - 1 PRC-FTX-SG17-SG23				
FTX - 5 Free text				
UN/EDIFACT Directory 96.A C		D6 D		CRG D
A segment providing free text instruction relating to the payment details.				
Segment number : 61				
UN/EDIFACT Directory 96.A		D6 Description		CRG Description
4451 Text subject qualifier	M an..3	M	*R	PMD = Payment detail/remittance information
4453 Text function, coded	C an..3	N		
C107 Text reference	C	N		
4441 Free text, coded	M an..3			
1131 Code list qualifier	C an..3			
3055 Code list responsible agency, coded	C an..3			
C108 Text literal	C	R		
4440 Free text	M an..70	M		
4440 Free text	C an..70	O		
4440 Free text	C an..70	O		
4440 Free text	C an..70	O		
4440 Free text	C an..70	O		
3453 Language, coded	C an..3	O		
<u>Example:</u> FTX+PMD+++SALARY DUE'				

SG4 - 9999 LIN-DTM-RFF-BUS-FCA-SG5-SG6-SG7-SG8-SG9-SG10-SG11					
SG11 - 9999 SEQ-MOA-DTM-RFF-PAI-FCA-SG12-SG13-SG14-SG15-SG16					
SG16 - 1 PRC-FTX-SG17-SG23					
SG17 - 9999 DOC-MOA-DTM-RFF-NAD-SG18-SG19-SG20					
UN/EDIFACT Directory 96.A C		D6 D		CRG D	
A group of segments providing details of all documents, e.g., invoices, statements, despatch advices, etc..., to which the Multiple Payment Order refers. It includes information on the monetary amounts for each document and on any adjustments (with an indication of the reason for adjustments) and discounts. For information purposes an indication of the tax element can be provided.		The contents of this SG (SGs 17 to 23) are specified by the trading partners' requirements. The user handbook issuer is not liable for the content and usage of details of payment specified in this SG. The usage of codes in this SG should be in line with those of the customer-to-customer remittance advice.			
DOC - 1 Document/message details					
UN/EDIFACT Directory 96.A M		D6 M		CRG M	
A segment identifying the reference document against which payment is being made.		The contents of this segment are specified by trading partners' requirements. The usage of codes in this segment should be in line with those of the customer-to-customer remittance advice.			
Segment number : 62					
UN/EDIFACT Directory 96.A			D6 Description		CRG Description
C002	Document/message name	M	M		
1001	Document/message name, coded	C an..3	O		The most frequent codes are: 380 = Commercial invoice 381 = Credit note, goods and services 383 = Debit note, goods and services 389 = Self billed invoice
1131	Code list qualifier	C an..3	O		
3055	Code list responsible agency, coded	C an..3	O		
1000	Document/message name	C an..35	O		
C503	Document/message details	C	O		
1004	Document/message number	C an..35	O		
1373	Document/message status, coded	C an..3	O		
1366	Document/message source	C an..35	O		
3453	Language, coded	C an..3	O		
3153	Communication channel identifier, coded	C an..3	O		

1220	Number of copies of document required	C n..2	O				
1218	Number of originals of document required	C n..2	O				

SG4 - 9999 LIN-DTM-RFF-BUS-FCA-SG5-SG6-SG7-SG8-SG9-SG10-SG11			
SG11 - 9999 SEQ-MOA-DTM-RFF-PAI-FCA-SG12-SG13-SG14-SG15-SG16			
SG16 - 1 PRC-FTX-SG17-SG23			
SG17 - 9999 DOC-MOA-DTM-RFF-NAD-SG18-SG19-SG20			
MOA - 5 Monetary amount			
UN/EDIFACT Directory 96.A C		D6 O	
A segment giving the monetary amounts of each reference document (e.g., original amount, discount amount etc.). The amount due and the amount remitted are mandatory.		The contents of this segment are specified by trading partners' requirements. The usage of codes in this segment should be in line with those of the customer-to-customer remittance advice.	
Segment number : 63			
UN/EDIFACT Directory 96.A		D6 Description	
C516 Monetary amount		M	M
5025 Monetary amount type qualifier	M an..3	M	
5004 Monetary amount	C n..18	O	
6345 Currency, coded	C an..3	O	
6343 Currency qualifier	C an..3	O	
4405 Status, coded	C an..3	O	
		CRG Description	
		The most frequent codes are: 9 = Amount due/amount payable 12 = Amount remitted 210 = Credit note amount	

SG4 - 9999 LIN-DTM-RFF-BUS-FCA-SG5-SG6-SG7-SG8-SG9-SG10-SG11		
SG11 - 9999 SEQ-MOA-DTM-RFF-PAI-FCA-SG12-SG13-SG14-SG15-SG16		
SG16 - 1 PRC-FTX-SG17-SG23		
SG17 - 9999 DOC-MOA-DTM-RFF-NAD-SG18-SG19-SG20		
DTM - 5 Date/time/period		
UN/EDIFACT Directory 96.A C	D6 O	CRG O
A segment specifying the date of the referenced document and indicating any other relevant dates applicable.	The contents of this segment are specified by trading partners' requirements. The usage of codes in this segment should be in line with those of the customer-to-customer remittance advice.	
Segment number : 64		
UN/EDIFACT Directory 96.A	D6 Description	CRG Description
C507 Date/time/period	M	M
2005 Date/time/period qualifier	M an..3	M
2380 Date/time/period	C an..35	O
2379 Date/time/period format qualifier	C an..3	O
		The most frequent code is: 137 = Document/message date/time
		The most frequent code is: 102 = CCYYMMDD

SG4 - 9999 LIN-DTM-RFF-BUS-FCA-SG5-SG6-SG7-SG8-SG9-SG10-SG11		
SG11 - 9999 SEQ-MOA-DTM-RFF-PAI-FCA-SG12-SG13-SG14-SG15-SG16		
SG16 - 1 PRC-FTX-SG17-SG23		
SG17 - 9999 DOC-MOA-DTM-RFF-NAD-SG18-SG19-SG20		
RFF - 5 Reference		
UN/EDIFACT Directory 96.A C	D6 O	CRG N
A segment for the inclusion of any additional references related to the reference document.	The contents of this segment are specified by trading partners' requirements. The usage of codes in this segment should be in line with those of the customer-to-customer remittance advice.	Not used
Segment number : 65		
UN/EDIFACT Directory 96.A	D6 Description	CRG Description
C506 Reference	M	M
1153 Reference qualifier	M an..3	M
1154 Reference number	C an..35	O
1156 Line number	C an..6	O
4000 Reference version number	C an..35	O

SG4 - 9999 LIN-DTM-RFF-BUS-FCA-SG5-SG6-SG7-SG8-SG9-SG10-SG11			
SG11 - 9999 SEQ-MOA-DTM-RFF-PAI-FCA-SG12-SG13-SG14-SG15-SG16			
SG16 - 1 PRC-FTX-SG17-SG23			
SG17 - 9999 DOC-MOA-DTM-RFF-NAD-SG18-SG19-SG20			
NAD - 2 Name and address			
UN/EDIFACT Directory 96.A C		D6 O	CRG N
A segment identifying a party name and address, either by coded identification or in a clear form.		The contents of this segment are specified by trading partners' requirements. The usage of codes in this segment should be in line with those of the customer-to-customer remittance advice.	Not used.
Segment number : 66			
UN/EDIFACT Directory 96.A		D6 Description	CRG Description
3035 Party qualifier	M an..3	M	
C082 Party identification details	C	O	
3039 Party id. identification	M an..35	M	
1131 Code list qualifier	C an..3	O	
3055 Code list responsible agency, coded	C an..3	O	
C058 Name and address	C	O	
3124 Name and address line	M an..35	M	
3124 Name and address line	C an..35	O	
3124 Name and address line	C an..35	O	
3124 Name and address line	C an..35	O	
3124 Name and address line	C an..35	O	
C080 Party name	C	O	
3036 Party name	M an..35	M	
3036 Party name	C an..35	O	
3036 Party name	C an..35	O	
3036 Party name	C an..35	O	
3036 Party name	C an..35	O	
3045 Party name format, coded	C an..3	O	
C059 Street	C	O	
3042 Street and number/p.o. box	M an..35	M	
3042 Street and number/p.o. box	C an..35	O	
3042 Street and number/p.o. box	C an..35	O	
3042 Street and number/p.o. box	C an..35	O	

3164	City name	C an..35	O			
3229	Country sub-entity identification	C an..9	O			
3251	Postcode identification	C an..9	O			
3207	Country, coded	C an..3	O	ISO 3166 two alpha country code.		

SG4 - 9999 LIN-DTM-RFF-BUS-FCA-SG5-SG6-SG7-SG8-SG9-SG10-SG11		
SG11 - 9999 SEQ-MOA-DTM-RFF-PAI-FCA-SG12-SG13-SG14-SG15-SG16		
SG16 - 1 PRC-FTX-SG17-SG23		
SG17 - 9999 DOC-MOA-DTM-RFF-NAD-SG18-SG19-SG20		
SG18 - 5 CUX-DTM		
UN/EDIFACT Directory 96.A C	D6 O	CRG N
A group of segments specifying the currencies and the related dates/periods valid to the referenced document where different to the reference currency.	The contents of this SG are specified by the trading partners' requirements. The user handbook issuer is not liable for the content and usage of details of payment specified in this SG. The usage of codes in this SG should be in line with those of the customer-to-customer remittance advice.	Not used.
CUX - 1 Currencies		
UN/EDIFACT Directory 96.A M	D6 M	CRG N
A segment identifying the currency and associated exchange rate of the referenced document where different to the remittance currency.	The contents of this segment are specified by trading partners' requirements. The usage of codes in this segment should be in line with those of the customer-to-customer remittance advice.	Not used.
Segment number : 67		
UN/EDIFACT Directory 96.A	D6 Description	CRG Description
C504 Currency details	C O	
6347 Currency details qualifier	M an..3 M	
6345 Currency, coded	C an..3 O	
6343 Currency qualifier	C an..3 O	
6348 Currency rate base	C n..4 O	
C504 Currency details	C O	
6347 Currency details qualifier	M an..3 M	
6345 Currency, coded	C an..3 O	
6343 Currency qualifier	C an..3 O	
6348 Currency rate base	C n..4 O	
5402 Rate of exchange	C n..12 O	
6341 Currency market exchange, coded	C an..3 O	

SG4 - 9999 LIN-DTM-RFF-BUS-FCA-SG5-SG6-SG7-SG8-SG9-SG10-SG11					
SG11 - 9999 SEQ-MOA-DTM-RFF-PAI-FCA-SG12-SG13-SG14-SG15-SG16					
SG16 - 1 PRC-FTX-SG17-SG23					
SG17 - 9999 DOC-MOA-DTM-RFF-NAD-SG18-SG19-SG20					
SG18 - 5 CUX-DTM					
DTM - 1 Date/time/period					
UN/EDIFACT Directory 96.A C			D6 O		CRG N
A segment specifying the date/time/period related to the rate of exchange.			The contents of this segment are specified by trading partners' requirements. The usage of codes in this segment should be in line with those of the customer-to-customer remittance advice.		Not used.
Segment number : 68					
UN/EDIFACT Directory 96.A			D6 Description		CRG Description
C507	Date/time/period	M	M		
2005	Date/time/period qualifier	M an..3	M		
2380	Date/time/period	C an..35	O		
2379	Date/time/period format qualifier	C an..3	O		

SG4 - 9999 LIN-DTM-RFF-BUS-FCA-SG5-SG6-SG7-SG8-SG9-SG10-SG11					
SG11 - 9999 SEQ-MOA-DTM-RFF-PAI-FCA-SG12-SG13-SG14-SG15-SG16					
SG16 - 1 PRC-FTX-SG17-SG23					
SG17 - 9999 DOC-MOA-DTM-RFF-NAD-SG18-SG19-SG20					
SG19 - 100 AJT-MOA-RFF-FTX					
UN/EDIFACT Directory 96.A C		D6 O		CRG O	
A group of segments indicating adjustment amounts and their referenced documents.		The contents of this SG are specified by the trading partners' requirements. The user handbook issuer is not liable for the content and usage of details of payment specified in this SG. The usage of codes in this SG should be in line with those of the customer-to-customer remittance advice.		This SG is to be used if there is a difference between the amount due and the amount remitted. Adjustments can be given for the whole referenced document identified in the DOC segment and, additionally, can be given per line item in the DLI (SG20).	
AJT - 1 Adjustment details					
UN/EDIFACT Directory 96.A M		D6 M		CRG M	
A segment indicating any adjustments to the amounts originally specified in the referenced document, and to which items such adjustments apply with the associated reason for adjustment.		The contents of this segment are specified by trading partners' requirements. The usage of codes in this segment should be in line with those of the customer-to-customer remittance advice.		Segment AJT is used to indicate the reason for an adjustment, e.g., damaged goods.	
Segment number : 69					
UN/EDIFACT Directory 96.A		D6 Description		CRG Description	
4465	Adjustment reason, coded	M an..3	M		The most frequent codes are: 1 = Agreed settlement 3 = Damaged goods 4 = Short delivery 5 = Price query 9 = Invoice error 14 = Wrong delivery 26 = Taxes 35 = Goods returned 39 = Deducted amount
1082	Line item number	C n..6	O		

SG4 - 9999 LIN-DTM-RFF-BUS-FCA-SG5-SG6-SG7-SG8-SG9-SG10-SG11		
SG11 - 9999 SEQ-MOA-DTM-RFF-PAI-FCA-SG12-SG13-SG14-SG15-SG16		
SG16 - 1 PRC-FTX-SG17-SG23		
SG17 - 9999 DOC-MOA-DTM-RFF-NAD-SG18-SG19-SG20		
SG19 - 100 AJT-MOA-RFF-FTX		
MOA - 1 Monetary amount		
UN/EDIFACT Directory 96.A M	D6 M	CRG M
A segment giving the monetary amounts of the adjustments of each reference document (e.g. original amounts, discount amount, etc.) The currency data elements should not be used.	The contents of this segment are specified by trading partners' requirements. The usage of codes in this segment should be in line with those of the customer-to-customer remittance advice.	Segment to indicate the value of the adjustment amount. Adjustment amounts may be given for information purposes only, i.e., not for calculation. The adjustment amount need not necessarily equal the difference between the amount due and the amount remitted. The adjustment amount will always be expressed in the payment currency.
Segment number : 70		
UN/EDIFACT Directory 96.A	D6 Description	CRG Description
C516 Monetary amount	M	M
5025 Monetary amount type qualifier	M an..3	M
5004 Monetary amount	C n..18	O
6345 Currency, coded	C an..3	O
6343 Currency qualifier	C an..3	O
4405 Status, coded	C an..3	O
		The most frequent code is: 165 = Adjustment amount Required DE. DE not used. DE not used. DE not used.

SG4 - 9999 LIN-DTM-RFF-BUS-FCA-SG5-SG6-SG7-SG8-SG9-SG10-SG11					
SG11 - 9999 SEQ-MOA-DTM-RFF-PAI-FCA-SG12-SG13-SG14-SG15-SG16					
SG16 - 1 PRC-FTX-SG17-SG23					
SG17 - 9999 DOC-MOA-DTM-RFF-NAD-SG18-SG19-SG20					
SG19 - 100 AJT-MOA-RFF-FTX					
RFF - 1 Reference					
UN/EDIFACT Directory 96.A C		D6 O		CRG O	
A segment for the inclusion of any additional references related to the reference documents.		The contents of this segment are specified by trading partners' requirements. The usage of codes in this segment should be in line with those of the customer-to-customer remittance advice.		Segment to specify references associated to the adjustment amounts.	
Segment number : 71					
UN/EDIFACT Directory 96.A		D6 Description			CRG Description
C506 Reference	M	M			The most frequent codes are: CT = Contract PL = Price list AAK = Despatch advice number ALO = Receiving advice number
1153 Reference qualifier	M an..3	M			
1154 Reference number	C an..35	O			
1156 Line number	C an..6	O			
4000 Reference version number	C an..35	O			

SG4 - 9999 LIN-DTM-RFF-BUS-FCA-SG5-SG6-SG7-SG8-SG9-SG10-SG11		
SG11 - 9999 SEQ-MOA-DTM-RFF-PAI-FCA-SG12-SG13-SG14-SG15-SG16		
SG16 - 1 PRC-FTX-SG17-SG23		
SG17 - 9999 DOC-MOA-DTM-RFF-NAD-SG18-SG19-SG20		
SG19 - 100 AJT-MOA-RFF-FTX		
FTX - 5 Free text		
UN/EDIFACT Directory 96.A C	D6 O	CRG N
A segment providing free text information related to the payment details.	The contents of this segment are specified by trading partners' requirements. The usage of codes in this segment should be in line with those of the customer-to-customer remittance advice.	Not used.
Segment number : 72		
UN/EDIFACT Directory 96.A	D6 Description	CRG Description
4451 Text subject qualifier	M an..3 M	
4453 Text function, coded	C an..3 O	
C107 Text reference	C O	
4441 Free text, coded	M an..3 M	
1131 Code list qualifier	C an..3 O	
3055 Code list responsible agency, coded	C an..3 O	
C108 Text literal	C O	
4440 Free text	M an..70 M	
4440 Free text	C an..70 O	
4440 Free text	C an..70 O	
4440 Free text	C an..70 O	
4440 Free text	C an..70 O	
3453 Language, coded	C an..3 O	

SG4 - 9999 LIN-DTM-RFF-BUS-FCA-SG5-SG6-SG7-SG8-SG9-SG10-SG11		
SG11 - 9999 SEQ-MOA-DTM-RFF-PAI-FCA-SG12-SG13-SG14-SG15-SG16		
SG16 - 1 PRC-FTX-SG17-SG23		
SG17 - 9999 DOC-MOA-DTM-RFF-NAD-SG18-SG19-SG20		
SG20 - 1000 DLI-MOA-PIA-DTM-SG21-SG22		
UN/EDIFACT Directory 96.A C	D6 O	CRG O
A group of segments which may be used when required to provide details of individual line items in the reference document.	The contents of this SG are specified by the trading partners' requirements. The user handbook issuer is not liable for the content and usage of details of payment specified in this SG. The usage of codes in this SG should be in line with those of the customer-to-customer remittance advice.	To provide information for individual line items within the document specified in the DOC segment.
DLI - 1 Document line identification		
UN/EDIFACT Directory 96.A M	D6 M	CRG M
A segment identifying a specific line item within the referenced document.	The contents of this segment are specified by trading partners' requirements. The usage of codes in this segment should be in line with those of the customer-to-customer remittance advice.	To indicate if the line item amount (given in next MOA segment) is included in the remittance amount or not, and to identify the line item number.
Segment number : 73		
UN/EDIFACT Directory 96.A	D6 Description	CRG Description
1073 Document line indicator, coded M an..3	M	The most frequent codes are: 1 = Included in document/transmission 2 = Excluded from document/transmission
1082 Line item number M n..6	M	

SG4 - 9999 LIN-DTM-RFF-BUS-FCA-SG5-SG6-SG7-SG8-SG9-SG10-SG11					
SG11 - 9999 SEQ-MOA-DTM-RFF-PAI-FCA-SG12-SG13-SG14-SG15-SG16					
SG16 - 1 PRC-FTX-SG17-SG23					
SG17 - 9999 DOC-MOA-DTM-RFF-NAD-SG18-SG19-SG20					
SG20 - 1000 DLI-MOA-PIA-DTM-SG21-SG22					
MOA - 5 Monetary amount					
UN/EDIFACT Directory 96.A M		D6 M		CRG M	
A segment giving the monetary amounts for this line item.		The contents of this segment are specified by trading partners' requirements. The usage of codes in this segment should be in line with those of the customer-to-customer remittance advice.		Segment to indicate the line item amount.	
Segment number : 74					
UN/EDIFACT Directory 96.A		D6 Description		CRG Description	
C516 Monetary amount	M	M			The most frequent code is: 203 = Line item amount
5025 Monetary amount type qualifier	M an..3	M			
5004 Monetary amount	C n..18	O			
6345 Currency, coded	C an..3	O			
6343 Currency qualifier	C an..3	O			
4405 Status, coded	C an..3	O			

SG4 - 9999 LIN-DTM-RFF-BUS-FCA-SG5-SG6-SG7-SG8-SG9-SG10-SG11				
SG11 - 9999 SEQ-MOA-DTM-RFF-PAI-FCA-SG12-SG13-SG14-SG15-SG16				
SG16 - 1 PRC-FTX-SG17-SG23				
SG17 - 9999 DOC-MOA-DTM-RFF-NAD-SG18-SG19-SG20				
SG20 - 1000 DLI-MOA-PIA-DTM-SG21-SG22				
PIA - 5 Additional product id				
UN/EDIFACT Directory 96.A C		D6 O		CRG N
A segment specifying item identification codes where required.		The contents of this segment are specified by trading partners' requirements. The usage of codes in this segment should be in line with those of the customer-to-customer remittance advice.		Not used.
Segment number : 75				
UN/EDIFACT Directory 96.A		D6 Description		CRG Description
4347 Product id. function qualifier	M an..3	M		
C212 Item number identification	M	M		
7140 Item number	C an..35	O		
7143 Item number type, coded	C an..3	O		
1131 Code list qualifier	C an..3	M		
3055 Code list responsible agency, coded	C an..3	O		
C212 Item number identification	C	O		
7140 Item number	C an..35	O		
7143 Item number type, coded	C an..3	O		
1131 Code list qualifier	C an..3	O		
3055 Code list responsible agency, coded	C an..3	O		
C212 Item number identification	C	O		
7140 Item number	C an..35	O		
7143 Item number type, coded	C an..3	O		
1131 Code list qualifier	C an..3	O		
3055 Code list responsible agency, coded	C an..3	O		
C212 Item number identification	C	O		

7140	Item number	C an..35	O			
7143	Item number type, coded	C an..3	O			
1131	Code list qualifier	C an..3	O			
3055	Code list responsible agency, coded	C an..3	O			

SG4 - 9999 LIN-DTM-RFF-BUS-FCA-SG5-SG6-SG7-SG8-SG9-SG10-SG11						
SG11 - 9999 SEQ-MOA-DTM-RFF-PAI-FCA-SG12-SG13-SG14-SG15-SG16						
SG16 - 1 PRC-FTX-SG17-SG23						
SG17 - 9999 DOC-MOA-DTM-RFF-NAD-SG18-SG19-SG20						
SG20 - 1000 DLI-MOA-PIA-DTM-SG21-SG22						
DTM - 5 Date/time/period						
UN/EDIFACT Directory 96.A C		D6 O		CRG N		
A segment specifying the date/time/period related to the line item.		The contents of this segment are specified by trading partners' requirements. The usage of codes in this segment should be in line with those of the customer-to-customer remittance advice.		Not used.		
Segment number : 76						
UN/EDIFACT Directory 96.A		D6 Description			CRG Description	
C507	Date/time/period	M	M			
2005	Date/time/period qualifier	M an..3	M			
2380	Date/time/period	C an..35	O			
2379	Date/time/period format qualifier	C an..3	O			

SG4 - 9999 LIN-DTM-RFF-BUS-FCA-SG5-SG6-SG7-SG8-SG9-SG10-SG11		
SG11 - 9999 SEQ-MOA-DTM-RFF-PAI-FCA-SG12-SG13-SG14-SG15-SG16		
SG16 - 1 PRC-FTX-SG17-SG23		
SG17 - 9999 DOC-MOA-DTM-RFF-NAD-SG18-SG19-SG20		
SG20 - 1000 DLI-MOA-PIA-DTM-SG21-SG22		
SG21 - 5 CUX-DTM		
UN/EDIFACT Directory 96.A C	D6 O	CRG N
A group of segments identifying the currency and the related dates/periods of the line item where different to the remittance and document currency.	The contents of this SG are specified by the trading partners' requirements. The user handbook issuer is not liable for the content and usage of details of payment specified in this SG. The usage of codes in this SG should be in line with those of the customer-to-customer remittance advice.	Not used.
CUX - 1 Currencies		
UN/EDIFACT Directory 96.A M	D6 M	CRG N
A segment identifying the currency and associated exchange rate of the line item, where different to the reference and target currency.	The contents of this segment are specified by trading partners' requirements. The usage of codes in this segment should be in line with those of the customer-to-customer remittance advice.	Not used.
Segment number : 77		
UN/EDIFACT Directory 96.A	D6 Description	CRG Description
C504 Currency details	C O	
6347 Currency details qualifier	M an..3 M	
6345 Currency, coded	C an..3 O	
6343 Currency qualifier	C an..3 O	
6348 Currency rate base	C n..4 O	
C504 Currency details	C O	
6347 Currency details qualifier	M an..3 M	
6345 Currency, coded	C an..3 O	
6343 Currency qualifier	C an..3 O	
6348 Currency rate base	C n..4 O	
5402 Rate of exchange	C n..12 O	
6341 Currency market exchange, coded	C an..3 O	

SG4 - 9999 LIN-DTM-RFF-BUS-FCA-SG5-SG6-SG7-SG8-SG9-SG10-SG11		
SG11 - 9999 SEQ-MOA-DTM-RFF-PAI-FCA-SG12-SG13-SG14-SG15-SG16		
SG16 - 1 PRC-FTX-SG17-SG23		
SG17 - 9999 DOC-MOA-DTM-RFF-NAD-SG18-SG19-SG20		
SG20 - 1000 DLI-MOA-PIA-DTM-SG21-SG22		
SG21 - 5 CUX-DTM		
DTM - 1 Date/time/period		
UN/EDIFACT Directory 96.A C	D6 O	CRG N
A segment specifying the effective date and/or time the rate of exchange was fixed.	The contents of this segment are specified by trading partners' requirements. The usage of codes in this segment should be in line with those of the customer-to-customer remittance advice.	Not used.
Segment number : 78		
UN/EDIFACT Directory 96.A	D6 Description	CRG Description
C507 Date/time/period	M	
2005 Date/time/period qualifier	M an..3	
2380 Date/time/period	C an..35	
2379 Date/time/period format qualifier	C an..3	

SG4 - 9999 LIN-DTM-RFF-BUS-FCA-SG5-SG6-SG7-SG8-SG9-SG10-SG11		
SG11 - 9999 SEQ-MOA-DTM-RFF-PAI-FCA-SG12-SG13-SG14-SG15-SG16		
SG16 - 1 PRC-FTX-SG17-SG23		
SG17 - 9999 DOC-MOA-DTM-RFF-NAD-SG18-SG19-SG20		
SG20 - 1000 DLI-MOA-PIA-DTM-SG21-SG22		
SG22 - 10 AJT-MOA-RFF-FTX		
UN/EDIFACT Directory 96.A C	D6 O	CRG N
A group of segments indicating adjustment amounts and their referenced documents for this line item.	The contents of this SG are specified by the trading partners' requirements. The user handbook issuer is not liable for the content and usage of details of payment specified in this SG. The usage of codes in this SG should be in line with those of the customer-to-customer remittance advice.	Not used.
AJT - 1 Adjustment details		
UN/EDIFACT Directory 96.A M	D6 M	CRG N
A segment indicating any adjustments to the amounts originally specified for this line item and the reason for the adjustments.	The contents of this segment are specified by trading partners' requirements. The usage of codes in this segment should be in line with those of the customer-to-customer remittance advice.	Not used.
Segment number : 79		
UN/EDIFACT Directory 96.A	D6 Description	CRG Description
4465 Adjustment reason, coded	Man..3 M	
1082 Line item number	C n..6 O	

SG4 - 9999 LIN-DTM-RFF-BUS-FCA-SG5-SG6-SG7-SG8-SG9-SG10-SG11		
SG11 - 9999 SEQ-MOA-DTM-RFF-PAI-FCA-SG12-SG13-SG14-SG15-SG16		
SG16 - 1 PRC-FTX-SG17-SG23		
SG17 - 9999 DOC-MOA-DTM-RFF-NAD-SG18-SG19-SG20		
SG20 - 1000 DLI-MOA-PIA-DTM-SG21-SG22		
SG22 - 10 AJT-MOA-RFF-FTX		
MOA - 1 Monetary amount		
UN/EDIFACT Directory 96.A M	D6 M	CRG N
A segment giving the monetary amounts of the adjustment for this line item.	The contents of this segment are specified by trading partners' requirements. The usage of codes in this segment should be in line with those of the customer-to-customer remittance advice.	Not used.
Segment number : 80		
UN/EDIFACT Directory 96.A	D6 Description	CRG Description
C516 Monetary amount	M	M
5025 Monetary amount type qualifier	M an..3	M
5004 Monetary amount	C n..18	O
6345 Currency, coded	C an..3	O
6343 Currency qualifier	C an..3	O
4405 Status, coded	C an..3	O

SG4 - 9999 LIN-DTM-RFF-BUS-FCA-SG5-SG6-SG7-SG8-SG9-SG10-SG11		
SG11 - 9999 SEQ-MOA-DTM-RFF-PAI-FCA-SG12-SG13-SG14-SG15-SG16		
SG16 - 1 PRC-FTX-SG17-SG23		
SG17 - 9999 DOC-MOA-DTM-RFF-NAD-SG18-SG19-SG20		
SG20 - 1000 DLI-MOA-PIA-DTM-SG21-SG22		
SG22 - 10 AJT-MOA-RFF-FTX		
RFF - 1 Reference		
UN/EDIFACT Directory 96.A C	D6 O	CRG N
A segment for the inclusion of any additional references related to the reference document.	The contents of this segment are specified by trading partners' requirements. The usage of codes in this segment should be in line with those of the customer-to-customer remittance advice.	Not used.
Segment number : 81		
UN/EDIFACT Directory 96.A	D6 Description	CRG Description
C506 Reference	M	M
1153 Reference qualifier	M an..3	M
1154 Reference number	C an..35	O
1156 Line number	C an..6	O
4000 Reference version number	C an..35	O

SG4 - 9999 LIN-DTM-RFF-BUS-FCA-SG5-SG6-SG7-SG8-SG9-SG10-SG11					
SG11 - 9999 SEQ-MOA-DTM-RFF-PAI-FCA-SG12-SG13-SG14-SG15-SG16					
SG16 - 1 PRC-FTX-SG17-SG23					
SG17 - 9999 DOC-MOA-DTM-RFF-NAD-SG18-SG19-SG20					
SG20 - 1000 DLI-MOA-PIA-DTM-SG21-SG22					
SG22 - 10 AJT-MOA-RFF-FTX					
FTX - 5 Free text					
UN/EDIFACT Directory 96.A C		D6 O		CRG N	
A segment providing free text information related to the payment details.		The contents of this segment are specified by trading partners' requirements. The usage of codes in this segment should be in line with those of the customer-to-customer remittance advice.		Not used.	
Segment number : 82					
UN/EDIFACT Directory 96.A			D6 Description		CRG Description
4451	Text subject qualifier	M an..3	M		
4453	Text function, coded	C an..3	O		
C107	Text reference	C	O		
4441	Free text, coded	M an..3	M		
1131	Code list qualifier	C an..3	O		
3055	Code list responsible agency, coded	C an..3	O		
C108	Text literal	C	O		
4440	Free text	M an..70	M		
4440	Free text	C an..70	O		
4440	Free text	C an..70	O		
4440	Free text	C an..70	O		
4440	Free text	C an..70	O		
3453	Language, coded	C an..3	O		

SG4 - 9999 LIN-DTM-RFF-BUS-FCA-SG5-SG6-SG7-SG8-SG9-SG10-SG11			
SG11 - 9999 SEQ-MOA-DTM-RFF-PAI-FCA-SG12-SG13-SG14-SG15-SG16			
SG16 - 1 PRC-FTX-SG17-SG23			
SG23 - 1 GIS-MOA			
UN/EDIFACT Directory 96.A C		D6 D	
A group of segments indicating the end of the details of payment and specifying hash total amounts for control purposes.		This SG is required to terminate the PRC segment group (SG 16).	
GIS - 1 General indicator			
UN/EDIFACT Directory 96.A M		D6 M	
A segment identifying the end of the details of payment.			
Segment number : 83			
UN/EDIFACT Directory 96.A		D6 Description	
C529 Processing indicator	M	M	37 = Complete information
7365 Processing indicator, coded	M an..3	M	
1131 Code list qualifier	C an..3	N	
3055 Code list responsible agency, coded	C an..3	N	
7187 Process type identification	C an..17	N	
<u>Example:</u> GIS+37'			

SG4 - 9999 LIN-DTM-RFF-BUS-FCA-SG5-SG6-SG7-SG8-SG9-SG10-SG11			
SG11 - 9999 SEQ-MOA-DTM-RFF-PAI-FCA-SG12-SG13-SG14-SG15-SG16			
SG16 - 1 PRC-FTX-SG17-SG23			
SG23 - 1 GIS-MOA			
MOA - 5 Monetary amount			
UN/EDIFACT Directory 96.A C		D6 O	
A segment indicating total amounts for control purposes.		CRG N	
		Not used.	
Segment number : 84			
UN/EDIFACT Directory 96.A		D6 Description	
		CRG Description	
C516 Monetary amount	M	M	
5025 Monetary amount type qualifier	M an..3	M	
5004 Monetary amount	C n..18	R	
6345 Currency, coded	C an..3	N	
6343 Currency qualifier	C an..3	N	
4405 Status, coded	C an..3	N	
<u>Example:</u>			
MOA+128:23800'			

CNT - 5 Control total					
UN/EDIFACT Directory 96.A C			D6 R		CRG R
A segment identifying the kind of control-checks for the payment orders contained in the PAYMUL and identifying the totals according to the coded form.					
Segment number : 85					
UN/EDIFACT Directory 96.A			D6 Description		CRG Description
C270 Control	M	M			
6069 Control qualifier	M an..3	M	*	2 = Number of line items in message (LIN segments) 39 = Total number of individual transactions (= total number of occurrences of SEQ segments). The usage of code 2 is recommended.	
			*		
6066 Control value	M n..18	M			
6411 Measure unit qualifier	C an..3	N			
<u>Example:</u>					
CNT+2:1'					

SG24 - 5 AUT-DTM					
UN/EDIFACT Directory 96.A C		D6 O		CRG N	
A group of segments specifying the details of any authentication (validation) procedure applied to the PAYMUL message.		The use of this SG, including algorithms and calculation procedures, is dependent on bilaterally agreed conditions between the sender and the receiver.		Not used.	
AUT - 1 Authentication result					
UN/EDIFACT Directory 96.A M		D6 M		CRG N	
A segment specifying details of any authentication (validation) procedures applied to the PAYMUL message.				Not used.	
Segment number : 86					
UN/EDIFACT Directory 96.A		D6 Description		CRG Description	
9280	Validation result	M an..35	M		
9282	Validation key identification	C an..35	O		
<u>Example:</u>					
AUT+283926'					

SG24 - 5 AUT-DTM					
DTM - 1 Date/time/period					
UN/EDIFACT Directory 96.A C			D6 R		CRG N
A segment identifying the validation date/time.					Not used.
Segment number : 87					
UN/EDIFACT Directory 96.A			D6 Description		CRG Description
C507	Date/time/period	M	M		
2005	Date/time/period qualifier	M an..3	M	218 = Authentication/validation date/time	
2380	Date/time/period	C an..35	R		
2379	Date/time/period format qualifier	C an..3	R	102 = CCYYMMDD The usage of code 102 is recommended. 203 = CCYYMMDDHHMM	
<u>Example:</u>					
DTM+218:19970630:102'					

UNT - 1 MESSAGE TRAILER					
UN/EDIFACT Directory 96.A M			D6 M		CRG M
A service segment ending a message, giving the total number of segments in the message and the control reference number of the message.					
Segment number : 88					
UN/EDIFACT Directory 96.A			D6 Description		CRG Description
0074	Number of segments in a message	M n..6	M		
0062	Message reference number	M an..14	M	This DE must have the same value as DE 0062 in the UNH segment, a sender-generated sequence number unique within an interchange.	
<u>Example:</u> UNT+88+19970630MJRF'					

4. History of changes

This PAYMUL MIG, version 1.1 of July 2000 contains the following changes, as compared to the previous version:

- Chapter 1 - Introduction New section.
- Chapter 2 - Message Layout New section.
- Chapter 3 - Segment Layout Addition of section “Introduction”.
- Chapter 3.2 - Segment Description Layout of table altered,
Consistency of descriptions improved
CRG comments incorporated.
- Chapter 4 - History of changes New section.